

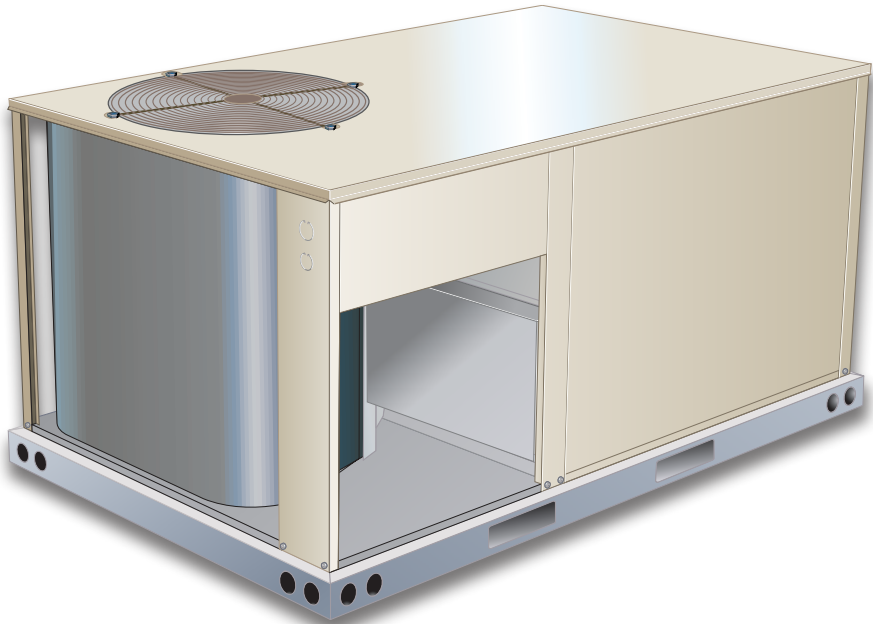

**COMMERCIAL  
PRODUCT SPECIFICATIONS**

Bulletin No. 210749  
January 2019  
Supersedes July 2018



**RAIDER®**  
Value Without Compromise™



**ASHRAE 90.1  
COMPLIANT**

**3 to 6 Tons**  
**Net Cooling Capacity - 35,000 to 69,000 Btuh**  
**Net Heating Capacity - 34,200 to 70,000 Btuh**  
**Optional Electric Heat - 5 to 30 kW**

**MODEL NUMBER IDENTIFICATION**

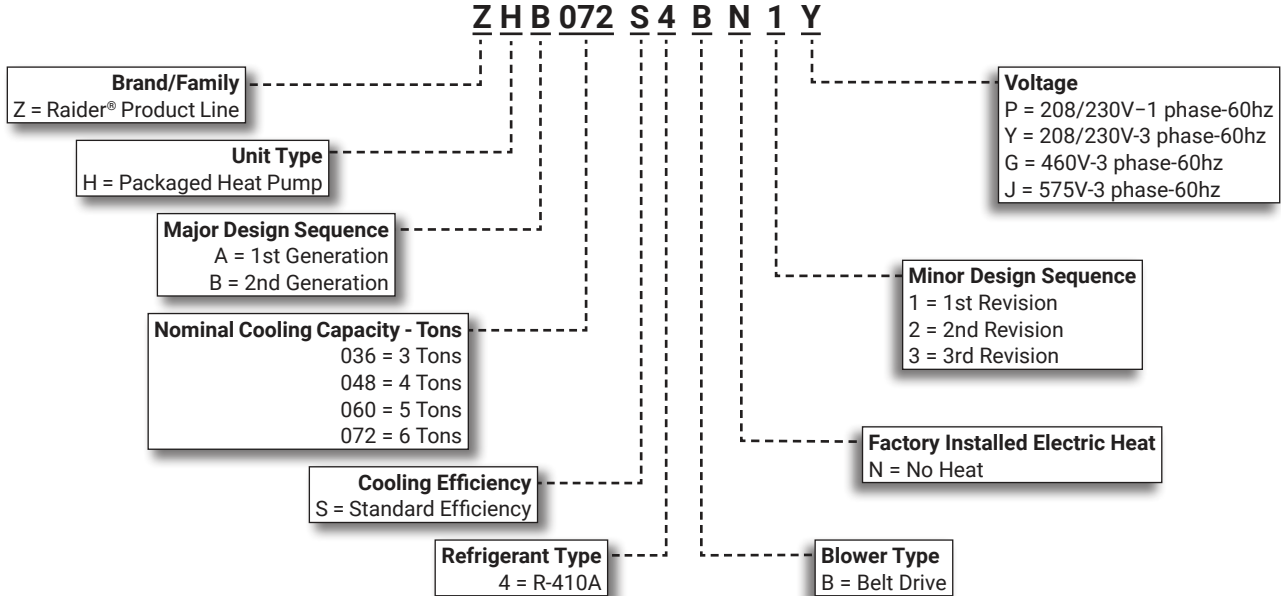

## FEATURE HIGHLIGHTS

Raider® rooftop units from Lennox Commercial are the new standard for cost efficient reliable, efficient rooftop units built for long-lasting performance that can significantly improve indoor environments.

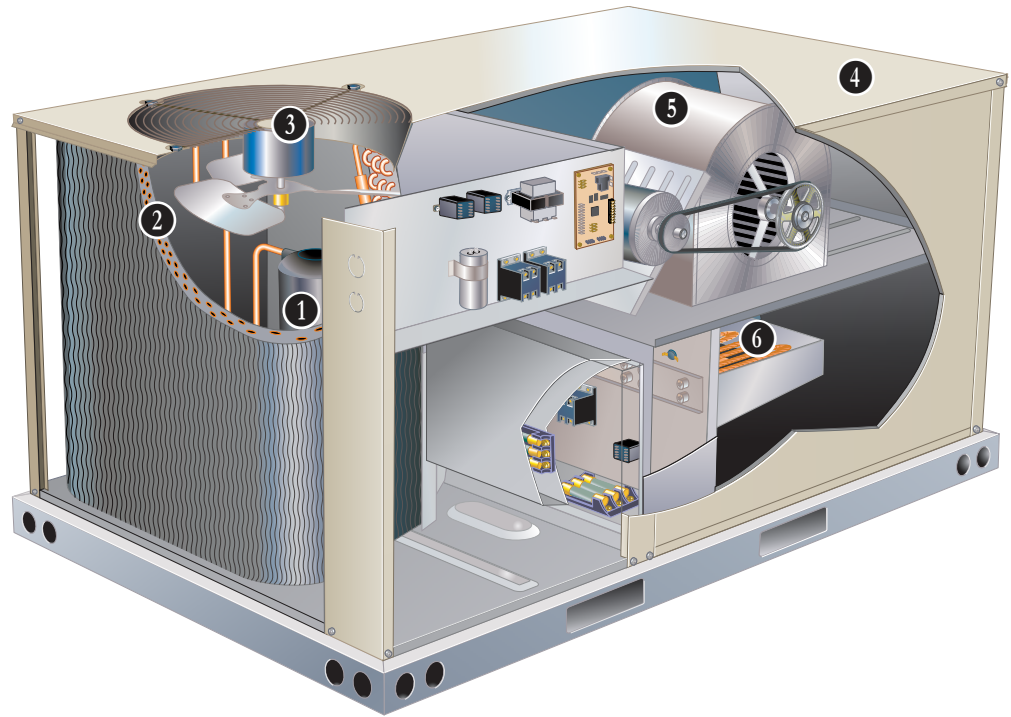

1. Scroll Compressor
2. Lennox' Environ™ Coil System
3. Outdoor Coil Fan Motor
4. Heavy Gauge Steel Cabinet
5. Supply Air Blower
6. Electric Heat (option)

## CONTENTS

Approvals And Warranty . . . . .	3
Blower Data . . . . .	17
Cooling / Heating Ratings - ZHA . . . . .	13
Cooling / Heating Ratings - ZHB . . . . .	15
Dimensions - Accessories . . . . .	39
Dimensions - Unit . . . . .	37
Electrical/Electric Heat Data . . . . .	27
Electric Heat Capacities . . . . .	34
Features And Benefits . . . . .	3
Model Number Identification. . . . .	1
Optional Conventional Temperature Control Systems . . . . .	8
Options / Accessories . . . . .	9
Outdoor Sound Data . . . . .	34
Specifications . . . . .	11
Unit Clearances . . . . .	35
Weight Data . . . . .	36

## APPROVALS AND WARRANTY

### APPROVALS

- AHRI Certified to AHRI Standard 210/240-2008 (3 - 5 ton models)
- AHRI Standard 340/360-2007 (6 ton models)
- CSA certified and listed
- Unit and components are UL, ULC, CEC and National and Canadian Electrical Codes bonded for grounding to meet safety standards for servicing
- All models are ASHRAE 90.1-2010 compliant
- All models meet DOE 2018 energy efficiency standards
- MSAV® equipped models meet California Code of Regulations, Title 24 and ASHRAE 90.1-2010 Section 6.4.3.10 requirements for staged airflow
- ISO 9001 Registered Manufacturing Quality System

### WARRANTY

- Compressors - Limited five years
- Lennox' Environ™ Coil System - Limited three years
- High Performance Economizers (optional) - Limited five years
- All other covered components - Limited one year

## FEATURES AND BENEFITS

### COOLING / HEATING SYSTEM

- Designed to maximize sensible and latent cooling performance at design conditions
- System can operate from 35°F to 125°F without any additional controls

#### **R-410A Refrigerant**

- Non-chlorine based
- Ozone friendly

#### **1 Compressor**

- Scroll compressors for high performance, reliability and quiet operation
- Resiliently mounted on rubber grommets for quiet operation

#### **Compressor Crankcase Heater**

- Protects against refrigerant migration that can occur during low ambient operation

#### **Refrigerant Metering Orifice (All ZHA and ZHB036 to 060 Models)**

- Accurately meters refrigerant in system
- Refrigerant control is accomplished by exact sizing of refrigerant metering orifice

#### **Thermal Expansion Valve (ZHB072 Models)**

- Assures optimal performance throughout the application range
- Removable element head

#### **Filter/Drier**

High capacity filter/drier protects the system from dirt and moisture **High Pressure Switch**

- Protects the compressor from overload conditions such as dirty condenser coils, blocked refrigerant flow, or loss of outdoor fan operation
- Automatic reset

#### **Reversing Valve**

- 4-way interchange reversing valve effects a rapid change in direction of refrigerant flow resulting in quick changeover from cooling to heating and vice versa

#### **Defrost Control**

- Provides a defrost cycle, if needed, every 30 or 60 or 90 minutes (adjustable) of compressor "on" time at outdoor coil temperature below 35°F
- Temperature switch mounted on outdoor coil liquid line terminates defrost cycle

#### **2 Coil Construction**

- Copper tube construction
- Enhanced rippled-edge aluminum fins
- Flared shoulder tubing connections
- Silver soldered construction
- Factory leak tested

#### **Indoor Coil**

- Cross row circuiting with rifled tubing optimizes both sensible and latent cooling capacity

#### **Condensate Drain Pan**

- Plastic pan, sloped to meet drainage requirements of ASHRAE 62.1
- End drain connection

#### **3 Outdoor Coil Fan Motor**

- Thermal overload protected
- Totally enclosed
- Permanently lubricated bearings
- Shaft down (all ZHA and ZHB036 to 060 models)
- Shaft up (ZHB072)
- Fan guard mount

#### **Outdoor Coil Fan Guard**

- PVC coated fan guard furnished

## FEATURES AND BENEFITS

### **COOLING / HEATING SYSTEM (continued)**

#### Required Selections

##### Cooling Capacity

- Specify nominal cooling capacity

#### Options/Accessories

##### Field Installed

###### Condensate Drain Trap

- Available in copper or PVC

###### Drain Pan Overflow Switch

- Monitors condensate level in drain pan
- Shuts down unit if drain becomes clogged

###### Low Ambient Kit

- Cycles the outdoor fans while allowing compressor operation in the cooling cycle
- Intermittent fan operation allows the system to operate without icing the evaporator coil and losing capacity
- Designed for use in ambient temperatures no lower than 0°F

### **CABINET**

#### 4 Construction

- Heavy-gauge steel panels
- Full perimeter heavy-gauge galvanized steel base rail
- Base rails have rigging holes
- Three sides of the base rail have forklift slots
- Raised edges around duct and power entry openings in the bottom of the unit for water protection

##### Airflow Choice

- Units are shipped in downflow (vertical) return air flow configuration

**NOTE** - Units can be field converted to horizontal airflow.

##### Power Entry

- Electrical lines can be brought through the unit base or through horizontal access knock-outs (end of unit on 036-060 model, side of unit on ZHB072 models)
- ZHB072 models feature three mounting locations for the disconnect:
  - Side mounting on an adjustable panel (removable corner base rail allows access for installation)
  - Side mounting directly over the side power entry knockouts
  - End mounting on an adjustable panel (alternate location)
- See dimension drawing

**NOTE** - Optional Bottom Power Entry Kit is available.

##### Exterior Panels

- Constructed of heavy-gauge, galvanized steel
- Two-layer enamel paint finish

##### Insulation

- All panels adjacent to conditioned air are fully insulated with non-hygroscopic fiberglass insulation

##### Access Panels

- Compressor
- Heating
- Controls
- Blower
- Air filter/economizer section

#### Options/Accessories

##### Factory Installed

###### Corrosion Protection

- Completely flexible immersed coating
- Electrodeposited dry film process (AST ElectroFin E-Coat)
- Meets Mil Spec MIL-P-53084, ASTM B117 Standard Method Salt Spray Testing
- Indoor Corrosion Protection
  - Coated coil
- Outdoor Corrosion Protection
  - Coated coil

##### Field Installed

###### Combination Coil/Hail Guards

- Heavy gauge steel frame
- Painted to match cabinet
- Expanded metal mesh protects outdoor coil

### **CONTROLS**

##### Unit Control

- All control voltage is provided via a 24V (secondary) transformer with inline fuse protection
- **Heat/Cool Staging** - Capable of up to 2 heat / 2 cool staging with a thermostat
- **Night Setback Mode** - Saves energy by closing outdoor air dampers and operating supply fan on thermostat demand only

##### Smoke Detectors

**NOTE** - Smoke detectors are not available and must be field provided by installer.

#### Options / Accessories

##### Field Installed

###### Commercial Control Systems

###### L Connection® Network

- Complete building automation control system for single or multi-zone applications
- Options include local interface, software for local or remote communication, and hardware for networking other control functions
- See L Connection Network Product Specifications Bulletin for details

## FEATURES AND BENEFITS

### **BLOWER**

A wide selection of supply air blower options are available to meet a variety of air flow requirements

#### **5 Motor**

- Overload protected
- Ball bearings
- Belt drive motors are offered on all models and are available in several different sizes to maximize air performance

#### **Supply Air Blower**

- Forward curved blades
- Blower wheel statically and dynamically balanced.
- Ball bearings
- Adjustable pulley (allows speed change)

#### **Required Selections**

#### **Supply Air Blower**

- Order blower motor horsepower and drive kit number required when base unit is ordered
- See Drive Kit Specifications Table

### **ELECTRICAL**

#### **Marked & Color-Coded Wiring**

- All electrical wiring is color-coded and marked to identify which components it is connecting.

#### **Electrical Plugs**

- Positive connection electrical plugs are used to connect common accessories or maintenance parts for easy removal or installation.

#### **Required Selections**

#### **Voltage Choice**

- Specify when ordering base unit.

#### **Field Installed**

#### **Bottom Power Entry Kit**

- Kit reduces the number of penetrations in the roof
- Kit includes bulkhead connectors to provides power and control wiring routing through the roof curb

#### **6 Electric Heat**

- Helix wound nichrome elements
- Individual element limit controls
- Wiring harness

**NOTE** - See Options / Accessories tables for ordering information.

**NOTE** - Unit Fuse Block is required and must be ordered separately. See Electrical / Electric Heat tables for ordering information.

### **INDOOR AIR QUALITY**

#### **Air Filters**

- Disposable 2 inch filters furnished as standard

#### **Options/Accessories**

#### **Field Installed**

#### **Indoor Air Quality (CO<sub>2</sub>) Sensor**

- Monitors CO<sub>2</sub> levels adjusts economizer dampers as needed for Demand Control Ventilation

## OPTIONS / ACCESSORIES

### ECONOMIZER

#### Factory or Field Installed

#### Economizer (Downflow or Horizontal) (Standard and High Performance Common Features)

- Outdoor Air Hood is furnished
- Includes Barometric Relief Dampers with Exhaust Hood
- Barometric Relief Dampers allow relief of excess air,
- Aluminum blade dampers prevent blow back and outdoor air infiltration during off cycle
- Exhaust hood with bird screen furnished
- Demand Control Ventilation (DCV) ready using optional CO<sub>2</sub> sensors
- Single temperature control is furnished with Economizer
- Outdoor air sensor enables Economizer if the outdoor temperature is less than the setpoint of the control

**NOTE** - Horizontal Economizer is field installed only.

#### Standard Economizer Features (Not for Title 24)

- Gear-driven action
- Return air and outdoor air dampers
- Plug-in connections to unit
- Nylon bearings
- Neoprene seals
- 24-volt
- Fully-modulating spring return motor

#### Standard Economizer Control Module

The Standard Economizer Control Module can be adjusted to operate based on outdoor air temperatures



#### Economizer Controls:

- **Damper Minimum Position** - Can be set lower than traditional minimum air requirements resulting in cost savings
- **IAQ Sensor** - Signals dampers to modulate and maintain 55°F when CO<sub>2</sub> is higher than the CO<sub>2</sub> setpoint
- **Demand Control Ventilation (DCV) LED** - A steady green Demand Control Ventilation LED indicates the IAQ reading is higher than setpoint and requires more fresh air
- **Free Cool LED** - A steady green LED indicates outdoor air is suitable for free cooling

**NOTE** - Free Cooling runs when outdoor air temperature is lower than the set temperature on the economizer control.

**NOTE:** The Free Cooling default setting for outdoor air temperature sensor is 55°F.

#### High Performance Economizer Features

- Approved for California Title 24 building standards
- Low leakage dampers are Air Movement and Control Association International (AMCA) Class 1A Certified - Maximum 3 CFM per sq. ft. leakage at 1 in. w.g.
- ASHRAE 90.1-2010 compliant
- Gear-driven action
- High torque 24-volt fully-modulating spring return damper motor
- Return air and outdoor air dampers
- Plug-in connections to unit
- Stainless steel bearings
- Enhanced neoprene blade edge seals
- Flexible stainless steel jamb seals minimize air leakage

**NOTE** - High Performance Economizers are not approved for use with enthalpy controls in Title 24 applications.

**NOTE** - The Free Cooling setpoint for Title 24 applications must be set based on the Climate Zone where the system is installed. See Section 140.4 "Prescriptive Requirements for Space Conditioning Systems" of the California Energy Commission's 2013 Building Energy Efficiency Standards. Refer to Installation Instructions for complete setup information and menu parameters available.

#### High Performance Economizer Control Module

- Module provides inputs and outputs to control economizer based on parameter settings
- Module automatically detects sensors by polling to determine which sensors are installed in system
- Module displays any alarm messages (fault detection and diagnostics) as an aid in troubleshooting
- Non-volatile memory retains parameter settings in case of power failure
- Keypad with four navigation buttons and LCD screen is furnished for setting economizer parameters
  - Menu Up/Exit (↑) button returns to the main menu
  - Arrow Up (▲) button moves to the previous or next parameter within the selected menu
  - Arrow Down (▼) button moves to the next parameter within the selected menu
  - Select (enter) (↵) button confirms parameter selection



## OPTIONS / ACCESSORIES

### **ECONOMIZER (continued)**

#### High Performance Economizer Control Module (continued)

##### Main Menu Structure:

- STATUS (economizer and system operation status)
- SETPOINTS (settings for various setpoint parameters)
- SYSTEM SETUP (settings/information about the system)
- ADVANCED SETUP (freeze protection, CO<sub>2</sub> settings, stage 3 delay, and additional calibration settings)
- CHECKOUT (damper positions)
- ALARMS (output signal that can be configured for remote alarm monitoring)

**NOTE** - Refer to Installation Instructions for complete setup information and menu parameters available.

### **Field Installed**

#### Single Enthalpy Temperature Control (Not for Title 24)

- Outdoor air enthalpy sensor enables Economizer if the outdoor enthalpy is less than the setpoint of the control

### **EXHAUST**

#### **Field Installed**

##### Power Exhaust Fan - Downflow or Horizontal

- Installs external to unit for applications with Economizer option
- Provides exhaust air pressure relief
- Interlocked to run when supply air blower is operating
- Fan runs when outdoor air dampers are 50% open (adjustable)
- Motor is overload protected
- Fan is 12 in. diameter
- Five fan blades
- 1/2 hp motor.

### **OUTDOOR AIR**

#### **Field Installed**

##### Outdoor Air Dampers - Downflow

- Single blade damper
- 0 to 25% (fixed) outdoor air adjustable
- Installs in unit
- Automatic model features fully modulating spring return damper motor with plug-in connection
- Manual model features a slide damper

**NOTE** - Maximum mixed air temperature in cooling mode is 100°F.

### **ROOF CURBS**

#### **Field Installed**

##### Hybrid Roof Curbs, Downflow

- Nail strip furnished; mates to unit
- US National Roofing Contractors approved
- Shipped knocked down
- Interlocking tabs fasten corners together; no tools required
- Can also be fastened together with furnished hardware
- Available in 8, 14, 18, and 24 inch heights

##### Adaptor Curbs (not shown)

- Curbs are regionally sourced
- Dimensions will vary based upon the source

**NOTE** - Contact your local sales representative for a detailed cut sheet with applicable dimensions.

### **CEILING DIFFUSERS**

#### **Field Installed**

- Flush or Step-Down
- White powder coat finish on diffuser face and grilles
- Insulated UL listed duct liner
- Diffuser box has collars for duct connection
- Step-down diffusers have double deflection blades
- Flush diffusers have fixed blades
- Provisions for suspending
- Internally sealed to prevent recirculation
- Removable return air grille
- Adapts to T-bar ceiling grids or plaster ceilings

##### Transitions (Supply and Return)

**NOTE** - Ceiling Diffuser Transitions are not furnished and must be field fabricated.

## OPTIONAL CONVENTIONAL TEMPERATURE CONTROL SYSTEMS

### ComfortSense® 7500 Commercial 7-Day Programmable Thermostat



- Four-Stage Heating / Two-Stage Cooling
- Universal Multi-Stage
- Intuitive Touchscreen Interface
- Automatic Changeover between Heating and Cooling
- Full Seven-Day Programming
- Four Time Periods Per Day
- Temperature and Humidity Control
- One-Touch Away Mode
- Holiday Scheduling
- Smooth Setback Recovery (SSR)
- Performance Reports
- Notifications/Reminders
- Economizer Relay Control
- Backlit Display
- Wallplate Furnished
- FDD, ASHRAE and IECC Compliant

### ComfortSense® 3000 Commercial 5-2 Day Programmable Thermostat

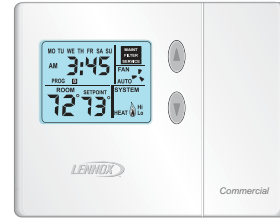

- Two-Stage Heating / Two-Stage Cooling
- Conventional Systems
- Intuitive Interface
- 5-2 Day Programming
- Program Hold
- Remote Indoor Temperature Sensing
- Smooth Setback Recovery (SSR)
- Economizer Relay Control
- Maintenance/Filter/Service Reminders
- Backlit Display
- Wallplate Furnished
- Simple Up and Down Temperature Control

### Bacnet Compatible Thermostat With Reheat Function



Description	Model No.	Catalog No.
<b>ComfortSense® 7500 7-Day Programmable</b>	C0STAT06FF2L	<b>17G74</b>
Universal thermostat locking guard (clear)	C0MISC15AE1-	<b>39P21</b>
<b>Temperature Sensors</b>	<sup>1</sup> Remote non-adjustable wall-mount 20k	<b>47W36</b>
	<sup>1</sup> Remote non-adjustable wall-mount 10k	<b>47W37</b>
	Remote non-adjustable discharge air (duct mount)	<b>19L22</b>
	Outdoor temperature sensor	<b>X2658</b>
<sup>1</sup> Remote wall-mount sensors can be applied in any of the following combinations: One Sensor - (1) 47W36, Two Sensors - (2) 47W37, Three Sensors - (2) 47W36 and (1) 47W37 Four Sensors - (4) 47W36, Five Sensors - (3) 47W36 and (2) 47W37		
<b>ComfortSense® 3000 5-2 Day Programmable</b>	C0STAT05FF1L	<b>11Y05</b>
Thermostat wall mounting plate	C0MISC17AE1-	<b>X2659</b>
<b>Temperature Sensor</b>	Remote non-adjustable wall mount 10k averaging	<b>47W37</b>
<b>BACnet Controls</b>	7-Day BACnet Thermostat	<b>Y8241</b>
	BACnet Module (factory or field)	<b>K0CTRL31B-2</b>
<sup>2</sup> <b>BACnet Room Sensors</b>	With Display	<b>K0SNSR01FF1</b>
	Without Display	<b>K0SNSR00FF1</b>
<b>BACnet Accessories</b>	Plenum Cable (RJ45/CAT5 75 ft.)	<b>K0MISC00FF1</b>

<sup>2</sup> Only compatible with BACnet Module (16X71).

- 7-Day Programmable
- BTL listed MS/TP ensures compatibility with any BACnet system
- Built-in control programs for conventional and heat pump applications
- Conventional systems up to 3-stage heat and 3-stage cool
- Heat pumps with 1 or 2 compressors and up to 2-stage auxiliary heat
- On-board temperature and humidity sensor
- Multiple configurable inputs and outputs enable advanced control strategies
- Set-up Wizard enables rapid system configuration
- No special tools required for installation or commissioning
- Seven-day (2, 4 or 6 event) occupancy scheduling per day
- Backlit 5-inch LCD touchscreen

## OPTIONS / ACCESSORIES

Item	Catalog No.	ZHA ZHB 036	ZHA ZHB 048	ZHA ZHB 060	ZHB 072
<b>COOLING SYSTEM</b>					
Condensate Drain Trap	PVC - C1TRAP20AD2 Copper - C1TRAP10AD2	<b>76W26</b> <b>76W27</b>	X X	X X	X X
Drain Pan Overflow Switch	Z1SNSR90A1	<b>99W59</b>	X	X	X
Low Ambient Kit	Z1SNSR34A-1	<b>99W68</b>	X	X	X
<b>BLOWER - SUPPLY AIR</b>					
Motors	Belt Drive - 0.75 hp (208/230V-1ph) Standard Efficiency	Factory	<sup>3</sup> O	<sup>3</sup> O	<sup>3</sup> O
	Belt Drive - 1 hp (208/230V, 460V, 575V-3ph) Standard Efficiency	Factory	O	O	O
	Belt Drive - 1.5 hp (208/230V-1ph or 3 ph, 460V, 575V-3ph) Standard Efficiency	Factory	O	O	O
	Belt Drive-2 hp (208/230V, 460V, 575V-3ph) Standard Efficiency	Factory			O
Drive Kits	Kit #ZA01 - 678-1035 rpm	Factory	O		
See Blower Data Tables for selection	Kit #ZA02 - 803-1226 rpm	Factory		O	
	Kit #ZA03 - 906-1383 rpm	Factory			<sup>4</sup> O
	Kit #ZA04 - 964-1471 rpm	Factory	O		
	<sup>1</sup> Kit #ZA05 - 1098-1490 rpm	Factory		O	
	<sup>1</sup> Kit #ZA06 - 1262-1634 rpm	Factory			<sup>4</sup> O
	Kit #ZAA01 - 522-784 rpm	Factory			<sup>3</sup> O
	Kit #ZAA02 - 632-875 rpm	Factory			<sup>3</sup> O O
	<sup>1</sup> Kit #ZAA03 - 798-1105 rpm	Factory			<sup>3</sup> O O
	Kit #ZAA04 - 921-1228 rpm	Factory			<sup>2</sup> O
<b>ELECTRICAL</b>					
Voltage	208/230V - 1 phase	Factory	<sup>3</sup> O	<sup>3</sup> O	<sup>3</sup> O
60 hz	208/230V - 3 phase	Factory	O	O	O
	460V - 3 phase	Factory	O	O	O
	575V - 3 phase	Factory	O	O	O
Bottom Power Entry Kit	Z1PEKT01A-1	<b>98W08</b>	X	X	X
<b>ELECTRIC HEAT</b>					
5 kW	208/230V-1ph - Z1EH0050AN1P	<b>98W96</b>	X	X	X
	208/230V-3ph - Z1EH0050AN1Y	<b>99W01</b>	X	X	X
	460V-3ph - Z1EH0050AN1G	<b>99W06</b>	X	X	X
	575V-3ph - Z1EH0050AN1J	<b>99W11</b>	X	X	X
7.5 kW	208/230V-1ph - Z1EH0075AN1P	<b>98W97</b>	X	X	X
	208/230V-3ph - Z1EH0075AN1Y	<b>99W02</b>	X	X	X
	460V-3ph - Z1EH0075AN1G	<b>99W07</b>	X	X	X
	575V-3ph - Z1EH0075AN1J	<b>99W12</b>	X	X	X
10 kW	208/230V-1ph - Z1EH0100AN1P	<b>98W98</b>	X	X	X
	208/230V-3ph - Z1EH0100AN1Y	<b>99W03</b>	X	X	X
	460V-3ph - Z1EH0100AN1G	<b>99W08</b>	X	X	X
	575V-3ph - Z1EH0100AN1J	<b>99W13</b>	X	X	X
15 kW	208/230V-1ph - Z1EH0150AN1P	<b>98W99</b>	X	X	X
	208/230V-3ph - Z1EH0150AN1Y	<b>99W04</b>	X	X	X
	460V-3ph - Z1EH0150AN1G	<b>99W09</b>	X	X	X
	575V-3ph - Z1EH0150AN1J	<b>99W14</b>	X	X	X
22.5 kW	208/230V-1ph - Z1EH0225AN1P	<b>99W00</b>		X	X
	208/230V-3ph - Z1EH0225AN1Y	<b>99W05</b>		X	X
	460V-3ph - Z1EH0225AN1G	<b>99W10</b>		X	X
	575V-3ph - Z1EH0225AN1J	<b>99W15</b>		X	X
30 kW	208/230V-3ph - Z1EH0300AN1Y	<b>13U01</b>			X
	460V-3PH - Z1EH0300AN1G	<b>13U02</b>			X
	575V-3PH - Z1EH0300AN1J	<b>13U03</b>			X
<b>ELECTRIC HEAT ACCESSORIES</b>					
Unit Fuse Block (required) - See Electrical/Electric Heat Tables for Selection			X	X	X

<sup>1</sup> 1.5 hp blower motor is the minimum required with the ZA05, ZA06 and ZAA03 drive kits.

<sup>2</sup> 2 hp blower motor is required with the ZAA04 drive kit.

<sup>3</sup> ZHB models only.

<sup>4</sup> ZHA models only.

NOTE - The catalog and model numbers that appear here are for ordering field installed accessories only.

OX - Field Installed or Configure to Order (Factory Installed)

O - Configure to Order (Factory Installed)

X - Field Installed.

## OPTIONS / ACCESSORIES

Item	Catalog No.	ZHA ZHB 036	ZHA ZHB 048	ZHA ZHB 060	ZHB 072	
<b>CABINET</b>						
Coil/Hail Guards	ZHA models only - Z1GARD52A-1	12X19	X	X		
	ZHA060 and ZHB models only - Z1GARD20AT1	12X20	X	X	X	
	ZHB072 model only - Z1GARD20AL1	16A41			X	
Corrosion Protection	Factory	O	O	O	O	
<b>ECONOMIZER</b>						
<b>Standard Economizer With Outdoor Air Hood (Not for Title 24)</b>						
Standard Economizer (Downflow) Includes Barometric Relief Dampers and Exhaust Hood	Z1ECON30A-2	14D94	OX	OX	OX	OX
Standard Economizer (Horizontal) Includes Barometric Relief Dampers and Exhaust Hood	Z1ECON16A-2	14D92	X	X	X	X
<b>Standard Economizer Controls (Not for Title 24)</b>						
Single Enthalpy Control	C1SNSR64FF1	53W64	X	X	X	X
<b>High Performance Economizer With Outdoor Air Hood (Approved for California Title 24 Building Standards / AMCA Class 1A Certified)</b>						
High Performance Economizer (Downflow) Includes Barometric Relief Dampers and Exhaust Hood	Z1ECON32A-2	14D95	OX	OX	OX	OX
High Performance Economizer (Horizontal) Includes Barometric Relief Dampers and Exhaust Hood	Z1ECON33A-2	14D93	X	X	X	X
<b>High Performance Economizer Controls (Not for Title 24)</b>						
Single Enthalpy Control	C1SNSR61FF1	11G21	X	X	X	X
<b>OUTDOOR AIR</b>						
<b>Outdoor Air Dampers - Includes Outdoor Air Hood</b>						
Motorized	Z1DAMP21A-2	15D19	X	X	X	X
Manual	Z1DAMP11A-2	15D20	X	X	X	X
<b>POWER EXHAUST FAN</b>						
Standard Static (Downflow)	208/230V-1 or 3ph - Z1PWRE10A-1P	21E01	X	X	X	X
	460V-3ph - Z1PWRE10A-1G	23E01	X	X	X	X
Standard Static (Horizontal)	208/230V-1 or 3ph - Z1PWRE15A-1P	24E01	X	X	X	X
	460V-3ph - Z1PWRE15A-1G	28E01	X	X	X	X
575V Transformer Kit	575V-3ph - Z1TRFM20A-1J	59E02	X	X	X	X
NOTE - Order 575V Transformer Kit with 208/230V Power Exhaust Fan for 575V applications.						
<b>INDOOR AIR QUALITY</b>						
<b>Indoor Air Quality (CO2) Sensors</b>						
Sensor - Wall-mount, off-white plastic cover with LCD display	C0SNSR50AE1L	77N39	X	X	X	X
Sensor - Wall-mount, black plastic case, no display, rated for plenum mounting	C0SNSR53AE1L	87N54	X	X	X	X
CO2 Sensor Duct Mounting Kit - for downflow applications	C0MISC19AE1	85L43	X	X	X	X
Aspiration Box - for duct mounting non-plenum rated CO2 sensor (77N39)	C0MISC16AE1	90N43	X	X	X	X
<b>ROOF CURBS</b>						
<b>Hybrid Roof Curbs, Downflow</b>						
8 in. height	Z1CURB70A-1	11F76	X	X	X	X
14 in. height	Z1CURB71A-1	11F77	X	X	X	X
18 in. height	Z1CURB72A-1	11F78	X	X	X	X
24 in. height	Z1CURB73A-1	11F79	X	X	X	X
<b>CEILING DIFFUSERS</b>						
Step-Down - Order one	RTD9-65S	13K60	X	X	X	
	RTD11-95S	13K61				X
Flush - Order one	FD9-65S	13K55	X	X	X	
	FD11-95S	13K56				X
NOTE - Ceiling Diffuser Transitions are not furnished and must be field fabricated.						
NOTE - The catalog and model numbers that appear here are for ordering field installed accessories only.						
OX - Field Installed or Configure to Order (Factory Installed)						
O - Configure to Order (Factory Installed)						
X - Field Installed.						

# SPECIFICATIONS

ZHA

General Data		Nominal Tonnage	3 Ton	4 Ton	5 Ton
		Model No.	ZHA036S4B	ZHA048S4B	ZHA060S4B
		Efficiency Type	Standard	Standard	Standard
<b>Cooling Performance</b>	Gross Cooling Capacity - Btuh		37,600	48,500	60,700
	<sup>1</sup> Net Cooling Capacity - Btuh		36,200	46,500	58,000
	AHRI Rated Air Flow - cfm		1310	1610	1940
	<sup>2</sup> Sound Rating Number (SRN) (dBA) Cooling		79	79	83
	Heating		80	80	83
	Total Unit Power - kW		3.1	4.3	5.3
		<sup>1</sup> SEER (Btuh/Watt)	13.00	13.00	13.00
		<sup>1</sup> EER (Btuh/Watt)	11.3	10.8	10.9
<b>Refrigerant</b>		Type	R-410A	R-410A	R-410A
		Charge Furnished	11 lbs. 12 oz.	12 lbs. 8 oz.	15 lbs. 3 oz.
<b>Heating Performance</b>	Total High Heating Capacity - Btuh		34,200	45,000	58,500
	Total Unit Power - kW		2.9	3.9	4.9
	<sup>1</sup> COP		3.42	3.40	3.50
	HSPF - Region IV (Region V)		7.70 (6.70)	7.70 (6.70)	7.70 (6.70)
	Total Low Heating Capacity - Btuh		20,400	27,400	33,400
	Total Unit Power - kW		2.8	3.6	4.5
		COP	2.18	2.24	2.20
<b>Electric Heat Available - See page 9</b>			<b>5, 7.5, 10, 15 kW</b>	<b>5, 7.5, 10, 15, 22.5 kW</b>	
<b>Compressor Type (one per unit)</b>			Scroll	Scroll	Scroll
<b>Outdoor Coil</b>	Net face area - sq. ft.		16.1	16.1	19.9
	Tube diameter - in.		3/8	3/8	3/8
	Number of rows		2	2	2
	Fins / inch		20	20	20
	Expansion device type		Balanced port TXV, removable head		
<b>Outdoor Coil Fan</b>	Motor HP		(1) 1/4 (PSC)	(1) 1/4 (PSC)	(1) 1/3 (PSC)
	Motor rpm		825	825	1075
	Total motor watts		300	300	340
	Diameter - in.		(1) 22	(1) 22	(1) 22
	Number of blades		4	4	3
	Total air volume - cfm		3200	3200	3600
<b>Indoor Coil</b>	Net face area - sq. ft.		8.4	8.4	9.6
	Tube diameter - in.		3/8	3/8	3/8
	Number of rows		3	3	3
	Fins per inch		14	14	14
	Drain Connection (no. and size) - in.		(1) 1 NPT	(1) 1 NPT	(1) 1 NPT
	Expansion device type		Fixed Orifice	Fixed Orifice	Fixed Orifice
<b><sup>3</sup> Indoor Blower &amp; Drive Selection</b>	Nominal Motor HP		1 hp, 1.5 hp	1 hp, 1.5 hp	1 hp, 1.5 hp
	Maximum Usable Motor HP		1.15 hp, 1.7 hp	1.15 hp, 1.7 hp	1.15 hp, 1.7 hp
	Available Drive Kits		Kit #ZA01 678-1035 rpm	Kit #ZA02 803-1226 rpm	Kit #ZA03 906-1383 rpm
			Kit #ZA04 964-1471 rpm	<sup>5</sup> Kit #ZA05 1098-1490 rpm	<sup>5</sup> Kit #ZA06 1262-1634 rpm
	Wheel nominal diameter x width - in.		10 x 10	10 x 10	10 x 10
<b>Filters</b>	Type		Disposable		
	Number and size - in.		(4) 14 x 20 x 2	(4) 14 x 20 x 2	(4) 16 x 20 x 2
<b>Electrical Characteristics - 60 Hz</b>			208/230V, 460V & 575V 3 phase	208/230V 460V & 575V 3 phase	208/230V 460V & 575V 3 phase

NOTE - Net capacity includes evaporator blower motor heat deduction. Gross capacity does not include evaporator blower motor heat deduction.

<sup>1</sup> AHRI Certified to AHRI Standard 210/240:

**Cooling Ratings** - 95°F outdoor air temperature and 80°F db/67°F wb entering indoor coil air.

**High Temperature Heating Ratings** - 47°F db/43°F wb outdoor air temperature and 70°F entering indoor coil air.

**Low Temperature Heating Ratings** - 17°F db/15°F wb outdoor air temperature and 70°F entering indoor coil air.

<sup>2</sup> Sound Rating Number (SRN) rated in accordance with test conditions included in ANSI/AHRI Standard 270-2008.

<sup>3</sup> Using total air volume and system static pressure requirements determine from blower performance tables rpm and motor hp required. Maximum usable hp of motors furnished are shown. In Canada, nominal motor hp is also maximum usable motor hp output. If motors of comparable hp are used, be sure to keep within the service factor limitations outlined on the motor nameplate.

<sup>5</sup> 1.5 hp motor is the minimum required with ZA05 and ZA06 drive kits.

**SPECIFICATIONS**

**ZHB**

General Data		Nominal Tonnage	3 Ton	4 Ton	5 Ton	6 Ton
		Model No.	ZHB036S4B	ZHB048S4B	ZHB060S4B	ZHB072S4B
Efficiency Type			Standard	Standard	Standard	Standard
<b>Cooling Performance</b>	Gross Cooling Capacity - Btuh		36,300	47,900	59,700	71,000
	Net Cooling Capacity - Btuh		<sup>1</sup> 35,000	<sup>1</sup> 46,500	<sup>1</sup> 58,000	<sup>2</sup> 69,000
	AHRI Rated Air Flow - cfm		1260	1520	2015	1860
	<sup>3</sup> Sound Rating Number (SRN) (dBA) Cooling		79	78	82	86
	Total Unit Power - kW		3.1	4.2	5.2	6.4
	SEER (Btuh/Watt)		<sup>1</sup> 14.00	<sup>1</sup> 14.00	<sup>1</sup> 14.00	---
	IEER (Btuh/Watt)		---	---	---	<sup>2</sup> 12.20
	EER (Btuh/Watt)		<sup>1</sup> 11.40	<sup>1</sup> 11.20	<sup>1</sup> 11.20	<sup>2</sup> 11.00
<b>Heating Performance</b>	Total High Heating Capacity - Btuh		34,200	45,000	55,000	70,000
	Total Unit Power - kW		2.9	3.8	4.5	6.3
	<sup>1</sup> COP		3.50	3.50	3.60	3.30
	HSPF - Region IV (Region V)		8.00 (6.70)	8.00 (6.70)	8.00 (6.70)	---
	Total Low Heating Capacity - Btuh		20,000	26,100	32,500	40,000
	Total Unit Power - kW		2.7	3.5	4.2	5.4
	COP		2.20	2.20	2.25	2.25
<b>Refrigerant</b>	Type		R-410A	R-410A	R-410A	R-410A
	Charge Furnished		14 lbs. 8 oz.	16 lbs. 5 oz.	14 lbs. 4 oz.	18 lbs. 0 oz.
<b>Electric Heat Available - See page 9</b>			<b>5, 7.5, 10, 15 kW</b>	<b>5, 7.5, 10, 15, 22.5 kW</b>	<b>7.5, 10, 15, 22.5, 30 kW</b>	
<b>Compressor Type (one per unit)</b>			Scroll	Scroll	Scroll	Scroll
<b>Outdoor Coil</b>	Net face area - sq. ft.		19.9	19.9	19.9	25.0
	Tube diameter - in.		3/8	3/8	3/8	3/8
	Number of rows		2	2	2	2
	Fins / inch		20	20	20	20
	Expansion device type		Balanced port TXV, removable head			
<b>Outdoor Coil Fan</b>	Motor HP		(1) 1/4	(1) 1/4	(1) 1/3	(1) 1/3
	Motor rpm		825	825	1075	1050
	Total motor watts		300	300	350	350
	Diameter - in.		(1) 22	(1) 22	(1) 22	(1) 24
	Number of blades		4	4	3	3
	Total air volume - cfm		3335	3335	3600	4350
<b>Indoor Coil</b>	Net face area - sq. ft.		9.6	10.8	10.8	10.8
	Tube diameter - in.		3/8	3/8	3/8	3/8
	Number of rows		3	3	3	3
	Fins per inch		14	14	14	14
	Drain Connection (no. and size) - in.		(1) 1 NPT	(1) 1 NPT	(1) 1 NPT	(1) 1 NPT
	Expansion device type		Fixed Orifice	Fixed Orifice	Fixed Orifice	Balanced port TXV, removable power head
<b><sup>4</sup> Indoor Blower &amp; Drive Selection</b>	Nominal Motor HP		<sup>5</sup> 0.75 hp, <sup>6</sup> 1 hp, 1.5 hp	<sup>5</sup> 0.75 hp, <sup>6</sup> 1 hp, 1.5 hp	<sup>5</sup> 0.75 hp, <sup>6</sup> 1 hp, 1.5 hp	1 hp, 1.5 hp, 2 hp
	Maximum Usable Motor HP		0.86 hp, 1.15 hp, 1.7 hp	0.86 hp, 1.15 hp, 1.7 hp	0.86 hp, 1.15 hp, 1.7 hp	1.15 hp, 1.7 hp, 2.3 hp
	Available Drive Kits		Kit #ZA01 678-1035 rpm	Kit #ZA02 803-1226 rpm	Kit #ZAA01 522-784 rpm	Kit #ZAA02 632-875 rpm
			Kit #ZA04 964-1471 rpm	<sup>7</sup> Kit #ZA05 1098-1490 rpm	Kit #ZAA02 632-875 rpm	<sup>7</sup> Kit #ZAA03 798-1105 rpm
		Wheel nominal diameter x width - in.		10 x 10	10 x 10	15 x 9
<b>Filters</b>	Type		Disposable			
	Number and size - in.		(4) 16 x 20 x 2	(2) 16 x 20 x 2 (2) 20 x 20 x 2	(2) 16 X 20 X 2 (2) 20 X 20 X 2	(2) 20 x 20 x 2 (2) 16 x 20 x 2
<b>Electrical Characteristics - 60 Hz</b>			208/230V 1 phase 208/230V, 460V & 575V 3 phase	208/230V, 1 phase 208/230V, 460V & 575V 3 phase	208/230V, 1 phase 208/230V, 460V & 575V 3 phase	208/230V 460V & 575V 3 Phase

NOTE - Net capacity includes evaporator blower motor heat deduction. Gross capacity does not include evaporator blower motor heat deduction.

<sup>1,2</sup> AHRI Certified to AHRI Standard <sup>1</sup> 210/240 or <sup>2</sup> 340/360:

**Cooling Ratings** - 95°F outdoor air temperature and 80°F db/67°F wb entering indoor coil air.

**High Temperature Heating Ratings** - 47°F db/43°F wb outdoor air temperature and 70°F entering indoor coil air.

**Low Temperature Heating Ratings** - 17°F db/15°F wb outdoor air temperature and 70°F entering indoor coil air.

<sup>3</sup> Sound Rating Number (SRN) rated in accordance with test conditions included in ANSI/AHRI Standard 270-2008.

<sup>4</sup> Using total air volume and system static pressure requirements determine from blower performance tables rpm and motor hp required. Maximum usable hp of motors furnished are shown. In Canada, nominal motor hp is also maximum usable motor hp output. If motors of comparable hp are used, be sure to keep within the service factor limitations outlined on the motor nameplate.

<sup>5</sup> 0.75 hp motor is only available for 208/230V-1ph applications.

<sup>6</sup> 1 hp blower motor is not available for 208/230V-1ph applications.

<sup>7</sup> 1.5 hp motor is the minimum required with ZA05 and ZAA03 drive kits.

<sup>8</sup> 2.0 hp motor is required with ZAA04 drive kits.

## COOLING / HEATING RATINGS - ZHA

NOTE – For Temperatures and Capacities not shown in tables, see bulletin – Cooling Unit Rating Table Correction Factor Data in Miscellaneous Engineering Data section.

### 3 TON COOLING STANDARD EFFICIENCY ZHA036S4

Entering Wet Bulb Temperature	Total Air Volume	Outdoor Air Temperature Entering Outdoor Coil																			
		85°F					95°F					105°F					115°F				
		Total Cool Cap.	Comp. Motor Input	Sensible To Total Ratio (S/T)			Total Cool Cap.	Comp. Motor Input	Sensible To Total Ratio (S/T)			Total Cool Cap.	Comp. Motor Input	Sensible To Total Ratio (S/T)			Total Cool Cap.	Comp. Motor Input	Sensible To Total Ratio (S/T)		
				Dry Bulb					Dry Bulb					Dry Bulb							
cfm	kBtuh	kW	75°F	80°F	85°F	kBtuh	kW	75°F	80°F	85°F	kBtuh	kW	75°F	80°F	85°F	kBtuh	kW	75°F	80°F	85°F	
63°F	960	34.6	2.05	0.74	0.88	1	33.2	2.35	0.75	0.89	1	31.4	2.68	0.76	0.92	1	28.6	3.01	0.79	0.96	1
	1200	36.5	2.06	0.79	0.95	1	35.1	2.36	0.81	0.97	1	33	2.68	0.83	1	1	30.3	3.03	0.86	1	1
	1440	38	2.06	0.85	1	1	36.6	2.36	0.86	1	1	34.7	2.7	0.89	1	1	31.8	3.04	0.94	1	1
67°F	960	36.8	2.06	0.58	0.71	0.84	35.4	2.36	0.59	0.72	0.86	33.4	2.69	0.59	0.74	0.88	30.3	3.02	0.61	0.77	0.93
	1200	38.7	2.07	0.61	0.77	0.92	37.1	2.37	0.62	0.78	0.94	34.9	2.7	0.63	0.81	0.97	31.6	3.03	0.66	0.85	1
	1440	40	2.07	0.65	0.82	0.99	38.2	2.37	0.66	0.84	1	35.9	2.7	0.67	0.87	1	32.4	3.04	0.7	0.92	1
71°F	960	38.9	2.07	0.44	0.56	0.69	37.3	2.37	0.44	0.57	0.7	35.2	2.7	0.44	0.58	0.72	31.9	3.04	0.45	0.6	0.75
	1200	40.9	2.08	0.45	0.6	0.74	39.1	2.38	0.45	0.61	0.76	36.7	2.71	0.46	0.62	0.78	33.2	3.05	0.47	0.65	0.83
	1440	42.4	2.08	0.47	0.64	0.8	40.4	2.39	0.47	0.65	0.82	37.8	2.72	0.47	0.67	0.85	34.1	3.05	0.49	0.7	0.9

### 3 TON HEATING STANDARD EFFICIENCY ZHA036S4

Indoor Coil Air Volume 70°F Dry Bulb cfm	Air Temperature Entering Outdoor Coil									
	65°F		45°F		25°F		5°F		-15°F	
	Total Heating Capacity	Comp. Motor Input	Total Heating Capacity	Comp. Motor Input	Total Heating Capacity	Comp. Motor Input	Total Heating Capacity	Comp. Motor Input	Total Heating Capacity	Comp. Motor Input
	kBtuh	kW	kBtuh	kW	kBtuh	kW	kBtuh	kW	kBtuh	kW
960	42.2	2.55	32.7	2.39	23.1	2.23	15.1	2.01	7.8	1.51
1200	42.4	2.37	32.9	2.21	23.3	2.04	15.3	1.82	7.9	1.32
1440	42.6	2.27	33.2	2.11	23.6	1.95	15.5	1.72	8.2	1.23

### 4 TON COOLING STANDARD EFFICIENCY ZHA048S4

Entering Wet Bulb Temperature	Total Air Volume	Outdoor Air Temperature Entering Outdoor Coil																			
		85°F					95°F					105°F					115°F				
		Total Cool Cap.	Comp. Motor Input	Sensible To Total Ratio (S/T)			Total Cool Cap.	Comp. Motor Input	Sensible To Total Ratio (S/T)			Total Cool Cap.	Comp. Motor Input	Sensible To Total Ratio (S/T)			Total Cool Cap.	Comp. Motor Input	Sensible To Total Ratio (S/T)		
				Dry Bulb					Dry Bulb					Dry Bulb							
cfm	kBtuh	kW	75°F	80°F	85°F	kBtuh	kW	75°F	80°F	85°F	kBtuh	kW	75°F	80°F	85°F	kBtuh	kW	75°F	80°F	85°F	
63°F	1280	46.3	2.99	0.73	0.88	1	41.9	3.39	0.73	0.9	1	37.3	3.85	0.74	0.93	1	32.5	4.39	0.76	0.97	1
	1600	49.4	3.01	0.79	0.96	1	44.8	3.41	0.81	0.98	1	40.2	3.87	0.83	1	1	35.6	4.41	0.86	1	1
	1920	52	3.03	0.85	1	1	47.7	3.42	0.87	1	1	43.2	3.89	0.9	1	1	38.4	4.44	0.94	1	1
67°F	1280	50.1	3.01	0.56	0.71	0.85	45.6	3.41	0.55	0.71	0.87	40.9	3.87	0.54	0.72	0.89	35.7	4.41	0.53	0.74	0.93
	1600	53.2	3.03	0.6	0.77	0.93	48.4	3.43	0.6	0.79	0.95	43.4	3.9	0.6	0.81	0.98	38	4.43	0.6	0.84	1
	1920	55.3	3.05	0.64	0.84	0.99	50.4	3.45	0.64	0.86	1	45.1	3.91	0.65	0.88	1	39.5	4.45	0.66	0.92	1
71°F	1280	53.8	3.03	0.4	0.55	0.69	49.3	3.43	0.39	0.54	0.69	44.3	3.9	0.36	0.54	0.71	39.1	4.44	0.33	0.53	0.72
	1600	57	3.06	0.43	0.59	0.75	52.1	3.46	0.41	0.59	0.77	47	3.93	0.39	0.6	0.79	41.5	4.47	0.37	0.6	0.82
	1920	59.5	3.08	0.45	0.64	0.82	54.3	3.48	0.43	0.64	0.84	48.8	3.95	0.42	0.65	0.86	43	4.49	0.4	0.67	0.9

### 4 TON HEATING STANDARD EFFICIENCY ZHA048S4

Indoor Coil Air Volume 70°F Dry Bulb cfm	Air Temperature Entering Outdoor Coil									
	65°F		45°F		25°F		5°F		-15°F	
	Total Heating Capacity	Comp. Motor Input	Total Heating Capacity	Comp. Motor Input	Total Heating Capacity	Comp. Motor Input	Total Heating Capacity	Comp. Motor Input	Total Heating Capacity	Comp. Motor Input
	kBtuh	kW	kBtuh	kW	kBtuh	kW	kBtuh	kW	kBtuh	kW
1280	54.5	3.33	42.3	3.12	29.7	2.91	20	2.64	9.9	1.98
1600	55.2	3.12	43.1	2.91	30.5	2.7	20.8	2.43	10.7	1.77
1920	55.9	3	43.8	2.79	31.2	2.58	21.5	2.31	11.4	1.64

## COOLING / HEATING RATINGS - ZHA

NOTE – For Temperatures and Capacities not shown in tables, see bulletin – Cooling Unit Rating Table Correction Factor Data in Miscellaneous Engineering Data section.

### 5 TON COOLING STANDARD EFFICIENCY ZHA060S4

Entering Wet Bulb Temperature	Total Air Volume	Outdoor Air Temperature Entering Outdoor Coil																			
		85°F					95°F					105°F					115°F				
		Total Cool Cap.	Comp. Motor Input	Sensible To Total Ratio (S/T)			Total Cool Cap.	Comp. Motor Input	Sensible To Total Ratio (S/T)			Total Cool Cap.	Comp. Motor Input	Sensible To Total Ratio (S/T)			Total Cool Cap.	Comp. Motor Input	Sensible To Total Ratio (S/T)		
				Dry Bulb					Dry Bulb					Dry Bulb					Dry Bulb		
cfm	kBtuh	kW	75°F	80°F	85°F	kBtuh	kW	75°F	80°F	85°F	kBtuh	kW	75°F	80°F	85°F	kBtuh	kW	75°F	80°F	85°F	
63°F	1600	58.4	3.7	0.73	0.88	1	53.3	4.17	0.74	0.9	1	47.8	4.72	0.75	0.93	1	42.1	5.37	0.77	0.96	1
	2000	62	3.72	0.79	0.95	1	56.8	4.2	0.81	0.98	1	51.1	4.75	0.83	1	1	45.7	5.42	0.86	1	1
	2400	65.2	3.74	0.85	1	1	60.2	4.22	0.87	1	1	54.7	4.79	0.9	1	1	49	5.46	0.94	1	1
67°F	1600	62.9	3.72	0.56	0.71	0.84	57.7	4.21	0.55	0.71	0.86	51.9	4.76	0.55	0.73	0.89	45.9	5.42	0.54	0.75	0.93
	2000	66.7	3.75	0.6	0.77	0.92	61.2	4.23	0.6	0.79	0.95	55.1	4.79	0.6	0.81	0.98	48.7	5.46	0.6	0.84	1
	2400	69.5	3.77	0.64	0.83	0.98	63.5	4.25	0.64	0.85	1	57.3	4.81	0.65	0.88	1	50.7	5.48	0.66	0.91	1
71°F	1600	67.4	3.75	0.41	0.55	0.68	62.1	4.24	0.39	0.55	0.69	56.1	4.8	0.38	0.54	0.71	50	5.47	0.35	0.54	0.73
	2000	71.3	3.78	0.43	0.59	0.75	65.7	4.27	0.42	0.59	0.77	59.5	4.84	0.4	0.6	0.79	52.8	5.5	0.39	0.6	0.82
	2400	74.4	3.8	0.45	0.63	0.81	68.3	4.29	0.44	0.64	0.83	61.7	4.86	0.43	0.65	0.86	54.9	5.54	0.42	0.67	0.89

### 5 TON HEATING STANDARD EFFICIENCY ZHA060S4

Indoor Coil Air Volume 70°F Dry Bulb cfm	Air Temperature Entering Outdoor Coil									
	65°F		45°F		25°F		5°F		-15°F	
	Total Heating Capacity	Comp. Motor Input	Total Heating Capacity	Comp. Motor Input	Total Heating Capacity	Comp. Motor Input	Total Heating Capacity	Comp. Motor Input	Total Heating Capacity	Comp. Motor Input
	kBtuh	kW	kBtuh	kW	kBtuh	kW	kBtuh	kW	kBtuh	kW
1600	72.9	4.28	55.2	3.98	36.8	3.68	23.8	3.28	12.1	2.45
2000	73.7	4.04	56	3.74	37.6	3.44	24.6	3.04	13	2.21
2400	74.4	3.9	56.7	3.6	38.3	3.29	25.3	2.9	13.6	2.07

## COOLING / HEATING RATINGS - ZHB

NOTE – For Temperatures and Capacities not shown in tables, see bulletin – Cooling Unit Rating Table Correction Factor Data in Miscellaneous Engineering Data section.

### 3 TON COOLING STANDARD EFFICIENCY ZHB036S4

Entering Wet Bulb Temperature	Total Air Volume	Outdoor Air Temperature Entering Outdoor Coil																			
		85°F					95°F					105°F					115°F				
		Total Cool Cap.	Comp. Motor Input	Sensible To Total Ratio (S/T)			Total Cool Cap.	Comp. Motor Input	Sensible To Total Ratio (S/T)			Total Cool Cap.	Comp. Motor Input	Sensible To Total Ratio (S/T)			Total Cool Cap.	Comp. Motor Input	Sensible To Total Ratio (S/T)		
				Dry Bulb					Dry Bulb					Dry Bulb					Dry Bulb		
cfm	kBtuh	kW	75°F	80°F	85°F	kBtuh	kW	75°F	80°F	85°F	kBtuh	kW	75°F	80°F	85°F	kBtuh	kW	75°F	80°F	85°F	
63°F	960	34.7	2.11	0.7	0.85	1	31.7	2.38	0.7	0.88	1	28.6	2.7	0.72	0.92	1	25.4	3.08	0.74	0.96	1
	1200	36.9	2.12	0.76	0.95	1	33.8	2.39	0.78	0.98	1	30.7	2.71	0.8	1	1	27.7	3.09	0.84	1	1
	1440	38.9	2.13	0.83	1	1	36	2.4	0.85	1	1	33	2.73	0.89	1	1	29.7	3.09	0.93	1	1
67°F	960	37.3	2.12	0.54	0.68	0.82	34.3	2.4	0.53	0.68	0.84	31.1	2.71	0.53	0.7	0.87	27.7	3.08	0.53	0.72	0.92
	1200	39.6	2.13	0.58	0.74	0.91	36.3	2.4	0.58	0.76	0.94	32.9	2.73	0.58	0.78	0.98	29.4	3.09	0.59	0.81	1
	1440	41.2	2.14	0.61	0.8	0.99	37.8	2.41	0.62	0.83	1	34.3	2.73	0.63	0.86	1	30.5	3.09	0.64	0.91	1
71°F	960	40	2.13	0.39	0.53	0.66	36.8	2.41	0.38	0.52	0.66	33.6	2.72	0.37	0.52	0.68	30	3.09	0.35	0.52	0.7
	1200	42.4	2.15	0.41	0.57	0.72	39	2.42	0.4	0.57	0.73	35.5	2.73	0.39	0.58	0.75	31.8	3.1	0.38	0.58	0.79
	1440	44	2.16	0.43	0.61	0.78	40.5	2.43	0.42	0.62	0.81	36.9	2.74	0.42	0.62	0.84	33	3.11	0.41	0.64	0.88

### 3 TON HEATING STANDARD EFFICIENCY ZHB036S4

Indoor Coil Air Volume 70°F Dry Bulb cfm	Air Temperature Entering Outdoor Coil									
	65°F		45°F		25°F		5°F		-15°F	
	Total Heating Capacity	Comp. Motor Input	Total Heating Capacity	Comp. Motor Input	Total Heating Capacity	Comp. Motor Input	Total Heating Capacity	Comp. Motor Input	Total Heating Capacity	Comp. Motor Input
	kBtuh	kW	kBtuh	kW	kBtuh	kW	kBtuh	kW	kBtuh	kW
960	41.2	2.49	32	2.38	22.6	2.27	15.1	2.07	7.5	1.54
1200	41.9	2.32	32.7	2.22	23.3	2.11	15.9	1.91	8.2	1.38
1440	42.5	2.23	33.3	2.13	23.8	2.02	16.4	1.82	8.7	1.29

### 4 TON COOLING STANDARD EFFICIENCY ZHB048S4

Entering Wet Bulb Temperature	Total Air Volume	Outdoor Air Temperature Entering Outdoor Coil																			
		85°F					95°F					105°F					115°F				
		Total Cool Cap.	Comp. Motor Input	Sensible To Total Ratio (S/T)			Total Cool Cap.	Comp. Motor Input	Sensible To Total Ratio (S/T)			Total Cool Cap.	Comp. Motor Input	Sensible To Total Ratio (S/T)			Total Cool Cap.	Comp. Motor Input	Sensible To Total Ratio (S/T)		
				Dry Bulb					Dry Bulb					Dry Bulb					Dry Bulb		
cfm	kBtuh	kW	75°F	80°F	85°F	kBtuh	kW	75°F	80°F	85°F	kBtuh	kW	75°F	80°F	85°F	kBtuh	kW	75°F	80°F	85°F	
63°F	1280	45.5	2.92	0.69	0.85	1	41.9	3.32	0.7	0.87	1	38.2	3.78	0.71	0.9	1	34.1	4.32	0.73	0.95	1
	1600	48.4	2.93	0.75	0.94	1	44.7	3.32	0.77	0.97	1	40.9	3.78	0.79	1	1	37	4.32	0.82	1	1
	1920	50.9	2.93	0.81	1	1	47.4	3.35	0.84	1	1	43.7	3.81	0.87	1	1	39.7	4.32	0.91	1	1
67°F	1280	49	2.93	0.53	0.67	0.81	45.3	3.33	0.53	0.68	0.83	41.3	3.78	0.52	0.69	0.86	37.1	4.33	0.53	0.71	0.9
	1600	51.7	2.93	0.57	0.73	0.9	47.8	3.35	0.57	0.74	0.93	43.7	3.79	0.57	0.76	0.97	39.2	4.33	0.58	0.79	1
	1920	53.8	2.94	0.6	0.79	0.98	49.7	3.35	0.61	0.81	1	45.4	3.8	0.62	0.84	1	40.8	4.33	0.63	0.88	1
71°F	1280	52.3	2.93	0.39	0.52	0.65	48.5	3.35	0.38	0.52	0.66	44.5	3.8	0.37	0.52	0.67	40.1	4.35	0.35	0.52	0.69
	1600	55.3	2.94	0.41	0.56	0.71	51.3	3.35	0.4	0.56	0.72	47	3.82	0.39	0.57	0.74	42.3	4.35	0.38	0.58	0.77
	1920	57.4	2.95	0.43	0.6	0.77	53.1	3.37	0.42	0.6	0.79	48.8	3.84	0.41	0.62	0.82	43.8	4.35	0.41	0.63	0.86

### 4 TON HEATING STANDARD EFFICIENCY ZHB048S4

Indoor Coil Air Volume 70°F Dry Bulb cfm	Air Temperature Entering Outdoor Coil									
	65°F		45°F		25°F		5°F		-15°F	
	Total Heating Capacity	Comp. Motor Input	Total Heating Capacity	Comp. Motor Input	Total Heating Capacity	Comp. Motor Input	Total Heating Capacity	Comp. Motor Input	Total Heating Capacity	Comp. Motor Input
	kBtuh	kW	kBtuh	kW	kBtuh	kW	kBtuh	kW	kBtuh	kW
1280	50.8	3.58	43.4	3.18	36.2	2.77	25.6	2.42	12.2	1.85
1600	51.8	3.35	44.3	2.95	37.1	2.55	26.5	2.19	13.1	1.62
1920	52.5	3.21	45	2.82	37.9	2.41	27.3	2.06	13.9	1.48

## COOLING / HEATING RATINGS - ZHB

NOTE – For Temperatures and Capacities not shown in tables, see bulletin – Cooling Unit Rating Table Correction Factor Data in Miscellaneous Engineering Data section.

### 5 TON COOLING STANDARD EFFICIENCY ZHB060S4

Entering Wet Bulb Temperature	Total Air Volume	Outdoor Air Temperature Entering Outdoor Coil																			
		85°F					95°F					105°F					115°F				
		Total Cool Cap.	Comp. Motor Input	Sensible To Total Ratio (S/T)			Total Cool Cap.	Comp. Motor Input	Sensible To Total Ratio (S/T)			Total Cool Cap.	Comp. Motor Input	Sensible To Total Ratio (S/T)			Total Cool Cap.	Comp. Motor Input	Sensible To Total Ratio (S/T)		
				Dry Bulb					Dry Bulb					Dry Bulb					Dry Bulb		
cfm	kBtuh	kW	75°F	80°F	85°F	kBtuh	kW	75°F	80°F	85°F	kBtuh	kW	75°F	80°F	85°F	kBtuh	kW	75°F	80°F	85°F	
63°F	1600	56.7	3.61	0.68	0.86	1	50.2	4.08	0.68	0.87	1	43.5	4.65	0.68	0.9	1	36.6	5.32	0.68	0.94	1
	2000	61.2	3.63	0.75	0.95	1	54.6	4.11	0.76	0.98	1	47.7	4.68	0.78	1	1	41.2	5.36	0.8	1	1
	2400	65.3	3.66	0.82	1	1	58.9	4.14	0.84	1	1	52.4	4.7	0.86	1	1	45.4	5.38	0.9	1	1
67°F	1600	62.3	3.64	0.51	0.67	0.82	55.6	4.12	0.49	0.66	0.84	48.7	4.69	0.46	0.66	0.86	41.3	5.34	0.43	0.67	0.9
	2000	66.8	3.66	0.56	0.74	0.91	59.7	4.14	0.54	0.74	0.94	52.4	4.71	0.53	0.76	0.97	44.7	5.38	0.51	0.78	1
	2400	69.9	3.68	0.6	0.8	0.99	62.7	4.16	0.59	0.82	1	55.1	4.72	0.59	0.84	1	47.1	5.39	0.58	0.88	1
71°F	1600	67.9	3.66	0.36	0.51	0.65	61.2	4.15	0.33	0.49	0.65	53.9	4.71	0.28	0.47	0.65	46.5	5.4	0.24	0.45	0.65
	2000	72.6	3.69	0.39	0.56	0.72	65.4	4.18	0.36	0.55	0.73	57.8	4.74	0.33	0.54	0.74	49.8	5.41	0.28	0.52	0.76
	2400	75.9	3.71	0.41	0.6	0.78	68.4	4.19	0.39	0.6	0.8	60.5	4.76	0.36	0.59	0.82	52.2	5.44	0.32	0.6	0.86

### 5 TON HEATING STANDARD EFFICIENCY ZHB060S4

Indoor Coil Air Volume 70°F Dry Bulb cfm	Air Temperature Entering Outdoor Coil									
	65°F		45°F		25°F		5°F		-15°F	
	Total Heating Capacity	Comp. Motor Input	Total Heating Capacity	Comp. Motor Input	Total Heating Capacity	Comp. Motor Input	Total Heating Capacity	Comp. Motor Input	Total Heating Capacity	Comp. Motor Input
	kBtuh	kW	kBtuh	kW	kBtuh	kW	kBtuh	kW	kBtuh	kW
1600	61.7	3.84	52.8	3.65	44.4	3.46	31.7	3.14	15.1	2.34
2000	62.7	3.59	53.9	3.4	45.5	3.21	32.8	2.9	16.2	2.1
2400	63.7	3.45	54.8	3.26	46.4	3.07	33.7	2.75	17.1	1.95

### 6 TON COOLING STANDARD EFFICIENCY ZHB072S4

Entering Wet Bulb Temperature	Total Air Volume	Outdoor Air Temperature Entering Outdoor Coil																			
		85°F					95°F					105°F					115°F				
		Total Cool Cap.	Comp. Motor Input	Sensible To Total Ratio (S/T)			Total Cool Cap.	Comp. Motor Input	Sensible To Total Ratio (S/T)			Total Cool Cap.	Comp. Motor Input	Sensible To Total Ratio (S/T)			Total Cool Cap.	Comp. Motor Input	Sensible To Total Ratio (S/T)		
				Dry Bulb					Dry Bulb					Dry Bulb					Dry Bulb		
cfm	kBtuh	kW	75°F	80°F	85°F	kBtuh	kW	75°F	80°F	85°F	kBtuh	kW	75°F	80°F	85°F	kBtuh	kW	75°F	80°F	85°F	
63°F	1800	69.3	4.91	0.71	0.84	0.97	64.8	5.48	0.71	0.86	0.99	60	6.1	0.73	0.88	1	54.9	6.83	0.75	0.91	1
	2300	73.6	4.96	0.76	0.92	1	68.8	5.52	0.78	0.94	1	63.8	6.14	0.8	0.97	1	58.5	6.85	0.82	1	1
	2800	76.9	4.98	0.82	0.99	1	72.1	5.55	0.84	1	1	67.2	6.18	0.86	1	1	62	6.87	0.89	1	1
67°F	1800	73.8	4.96	0.56	0.68	0.81	69.1	5.52	0.56	0.69	0.83	64.2	6.14	0.56	0.71	0.85	58.7	6.85	0.56	0.72	0.88
	2300	78.1	4.99	0.59	0.74	0.89	73.1	5.56	0.6	0.76	0.91	67.6	6.17	0.6	0.78	0.94	62	6.86	0.61	0.8	0.98
	2800	81	5.01	0.62	0.8	0.96	75.7	5.57	0.63	0.82	0.98	70.2	6.19	0.64	0.84	1	64.4	6.89	0.66	0.87	1
71°F	1800	78.2	4.99	0.42	0.54	0.66	73.4	5.56	0.41	0.55	0.67	68.1	6.18	0.41	0.55	0.68	62.7	6.87	0.4	0.55	0.7
	2300	82.6	5.02	0.44	0.58	0.72	77.6	5.59	0.43	0.59	0.74	72	6.22	0.43	0.6	0.76	66.1	6.9	0.43	0.61	0.78
	2800	85.7	5.05	0.45	0.62	0.78	80.3	5.61	0.45	0.63	0.8	74.5	6.23	0.45	0.64	0.82	68.3	6.91	0.45	0.66	0.85

### 6 TON HEATING STANDARD EFFICIENCY ZHB072S4

Indoor Coil Air Volume 70°F Dry Bulb cfm	Air Temperature Entering Outdoor Coil									
	65°F		45°F		25°F		5°F		-15°F	
	Total Heating Capacity	Comp. Motor Input	Total Heating Capacity	Comp. Motor Input	Total Heating Capacity	Comp. Motor Input	Total Heating Capacity	Comp. Motor Input	Total Heating Capacity	Comp. Motor Input
	kBtuh	kW	kBtuh	kW	kBtuh	kW	kBtuh	kW	kBtuh	kW
1800	89.1	5.92	68.6	5.47	48.1	5.01	29.3	4.43	14.7	3.33
2300	90.5	5.56	70.1	5.1	49.5	4.64	30.8	4.06	16.1	2.97
2800	91.5	5.35	71	4.89	50.5	4.43	31.7	3.85	17.1	2.76

**BLOWER DATA**

**ZHA036**

**BLOWER TABLE INCLUDES RESISTANCE FOR BASE UNIT ONLY WITH DRY INDOOR COIL AND AIR FILTERS IN PLACE.**

FOR ALL UNITS ADD:

1 - Any factory installed options air resistance (heat section, economizer, wet coil, etc.).

2 - Any field installed accessories air resistance (duct resistance, diffuser, etc.).

See page 25 for blower motors and drives and wet coil and options/accessory air resistance data.

**DOWNFLOW**

Air Volume cfm	External Static - in. w.g.															
	0.10		0.20		0.30		0.40		0.50		0.60		0.70		0.80	
	RPM	BHP	RPM	BHP	RPM	BHP	RPM	BHP	RPM	BHP	RPM	BHP	RPM	BHP	RPM	BHP
900	562	0.16	629	0.18	699	0.19	771	0.2	840	0.22	904	0.24	962	0.26	1015	0.29
1000	586	0.18	654	0.2	725	0.21	796	0.23	864	0.25	927	0.27	983	0.3	1034	0.33
1100	612	0.2	681	0.22	752	0.24	823	0.26	890	0.28	950	0.31	1004	0.34	1054	0.37
1200	641	0.23	711	0.25	783	0.27	852	0.29	917	0.32	975	0.35	1027	0.39	1074	0.42
1300	673	0.25	744	0.28	815	0.3	882	0.33	944	0.36	1000	0.4	1050	0.44	1096	0.48
1400	709	0.29	779	0.32	849	0.34	914	0.37	973	0.41	1026	0.45	1074	0.49	1118	0.53
1500	747	0.33	816	0.36	883	0.39	945	0.42	1001	0.46	1052	0.51	1098	0.55	1141	0.59

Air Volume cfm	External Static - in. w.g.															
	0.90		1.00		1.10		1.20		1.30		1.40		1.50		1.60	
	RPM	BHP	RPM	BHP	RPM	BHP	RPM	BHP	RPM	BHP	RPM	BHP	RPM	BHP	RPM	BHP
900	1065	0.32	1112	0.35	1158	0.38	1202	0.41	1243	0.44	1284	0.48	1323	0.52	1364	0.55
1000	1082	0.36	1128	0.39	1173	0.42	1216	0.45	1257	0.49	1297	0.53	1336	0.57	1375	0.6
1100	1100	0.4	1145	0.44	1189	0.47	1231	0.51	1272	0.54	1311	0.58	1349	0.62	1388	0.66
1200	1119	0.45	1163	0.49	1206	0.52	1247	0.56	1287	0.6	1326	0.64	1364	0.68	1402	0.72
1300	1139	0.51	1182	0.55	1224	0.58	1265	0.62	1304	0.66	1342	0.71	1379	0.75	1416	0.79
1400	1160	0.57	1202	0.61	1243	0.65	1283	0.69	1322	0.73	1359	0.78	1396	0.82	1432	0.87
1500	1182	0.64	1223	0.68	1263	0.72	1303	0.76	1341	0.81	1378	0.85	1414	0.9	1449	0.94

**HORIZONTAL**

Air Volume cfm	External Static - in. w.g.															
	0.10		0.20		0.30		0.40		0.50		0.60		0.70		0.80	
	RPM	BHP	RPM	BHP	RPM	BHP	RPM	BHP	RPM	BHP	RPM	BHP	RPM	BHP	RPM	BHP
900	580	0.14	649	0.17	721	0.19	794	0.22	868	0.24	938	0.27	998	0.3	1045	0.33
1000	612	0.17	681	0.19	752	0.22	825	0.25	897	0.27	963	0.3	1017	0.33	1061	0.37
1100	647	0.2	717	0.23	788	0.26	858	0.28	926	0.31	986	0.34	1036	0.38	1077	0.41
1200	687	0.23	757	0.26	826	0.29	893	0.32	955	0.35	1008	0.39	1054	0.42	1095	0.46
1300	730	0.27	798	0.3	864	0.33	926	0.37	982	0.4	1030	0.44	1073	0.47	1116	0.51
1400	775	0.31	840	0.34	902	0.38	959	0.42	1009	0.46	1054	0.5	1096	0.53	1140	0.56
1500	820	0.36	881	0.4	939	0.44	993	0.49	1039	0.53	1082	0.56	1124	0.59	1168	0.62

Air Volume cfm	External Static - in. w.g.															
	0.90		1.00		1.10		1.20		1.30		1.40		1.50		1.60	
	RPM	BHP	RPM	BHP	RPM	BHP	RPM	BHP	RPM	BHP	RPM	BHP	RPM	BHP	RPM	BHP
900	1091	0.36	1140	0.38	1188	0.4	1232	0.43	1272	0.46	1309	0.49	1346	0.53	1383	0.57
1000	1105	0.4	1154	0.42	1201	0.45	1245	0.47	1284	0.5	1321	0.54	1357	0.58	1394	0.62
1100	1121	0.44	1169	0.47	1216	0.49	1259	0.52	1298	0.56	1335	0.6	1370	0.64	1406	0.69
1200	1139	0.49	1187	0.52	1234	0.54	1276	0.58	1314	0.62	1350	0.66	1385	0.71	1421	0.75
1300	1161	0.54	1208	0.57	1254	0.6	1295	0.64	1332	0.69	1366	0.73	1401	0.78	1436	0.83
1400	1185	0.59	1232	0.63	1276	0.67	1315	0.71	1351	0.76	1384	0.81	1419	0.86	1454	0.9
1500	1212	0.66	1257	0.7	1299	0.74	1337	0.79	1371	0.84	1404	0.89	1438	0.94	1473	0.99

**BLOWER TABLE INCLUDES RESISTANCE FOR BASE UNIT ONLY WITH DRY INDOOR COIL AND AIR FILTERS IN PLACE.**

FOR ALL UNITS ADD:

1 - Any factory installed options air resistance (heat section, economizer, wet coil, etc.).

2 - Any field installed accessories air resistance (duct resistance, diffuser, etc.).

See page 25 for blower motors and drives and wet coil and options/accessory air resistance data.

**DOWNFLOW**

Air Volume cfm	External Static - in. w.g.															
	0.10		0.20		0.30		0.40		0.50		0.60		0.70		0.80	
	RPM	BHP	RPM	BHP	RPM	BHP	RPM	BHP	RPM	BHP	RPM	BHP	RPM	BHP	RPM	BHP
1200	641	0.23	711	0.25	783	0.27	852	0.29	917	0.32	975	0.35	1027	0.39	1074	0.42
1300	673	0.25	744	0.28	815	0.30	882	0.33	944	0.36	1000	0.40	1050	0.44	1096	0.48
1400	709	0.29	779	0.32	849	0.34	914	0.37	973	0.41	1026	0.45	1074	0.49	1118	0.53
1500	747	0.33	816	0.36	883	0.39	945	0.42	1001	0.46	1052	0.51	1098	0.55	1141	0.59
1600	787	0.38	854	0.41	918	0.44	976	0.48	1030	0.52	1078	0.56	1123	0.61	1164	0.66
1700	827	0.43	892	0.46	952	0.49	1007	0.53	1058	0.58	1105	0.63	1148	0.68	1189	0.73
1800	868	0.48	929	0.52	986	0.55	1038	0.59	1087	0.64	1132	0.69	1174	0.75	1214	0.80
1900	907	0.54	966	0.58	1019	0.62	1069	0.66	1116	0.71	1160	0.77	1200	0.82	1240	0.88
2000	946	0.60	1001	0.65	1053	0.69	1101	0.74	1146	0.79	1188	0.85	1228	0.91	1267	0.98

Air Volume cfm	External Static - in. w.g.															
	0.90		1.00		1.10		1.20		1.30		1.40		1.50		1.60	
	RPM	BHP	RPM	BHP	RPM	BHP	RPM	BHP	RPM	BHP	RPM	BHP	RPM	BHP	RPM	BHP
1200	1119	0.45	1163	0.49	1206	0.52	1247	0.56	1287	0.60	1326	0.64	1364	0.68	1402	0.72
1300	1139	0.51	1182	0.55	1224	0.58	1265	0.62	1304	0.66	1342	0.71	1379	0.75	1416	0.79
1400	1160	0.57	1202	0.61	1243	0.65	1283	0.69	1322	0.73	1359	0.78	1396	0.82	1432	0.87
1500	1182	0.64	1223	0.68	1263	0.72	1303	0.76	1341	0.81	1378	0.85	1414	0.90	1449	0.94
1600	1205	0.70	1245	0.75	1284	0.79	1323	0.84	1361	0.88	1397	0.93	1432	0.98	1467	1.03
1700	1228	0.78	1268	0.82	1307	0.87	1345	0.92	1382	0.97	1417	1.02	1452	1.07	1486	1.11
1800	1253	0.85	1292	0.91	1331	0.96	1368	1.01	1404	1.06	1439	1.11	1473	1.16	1506	1.21
1900	1279	0.94	1317	1.00	1355	1.05	1392	1.10	1427	1.16	1461	1.21	1494	1.26	1527	1.31
2000	1305	1.04	1343	1.10	1380	1.15	1416	1.21	1450	1.26	1484	1.32	1516	1.37	1549	1.42

**HORIZONTAL**

Air Volume cfm	External Static - in. w.g.															
	0.10		0.20		0.30		0.40		0.50		0.60		0.70		0.80	
	RPM	BHP	RPM	BHP	RPM	BHP	RPM	BHP	RPM	BHP	RPM	BHP	RPM	BHP	RPM	BHP
1200	687	0.23	757	0.26	826	0.29	893	0.32	955	0.35	1008	0.39	1054	0.42	1095	0.46
1300	730	0.27	798	0.30	864	0.33	926	0.37	982	0.40	1030	0.44	1073	0.47	1116	0.51
1400	775	0.31	840	0.34	902	0.38	959	0.42	1009	0.46	1054	0.50	1096	0.53	1140	0.56
1500	820	0.36	881	0.40	939	0.44	993	0.49	1039	0.53	1082	0.56	1124	0.59	1168	0.62
1600	864	0.42	921	0.46	976	0.51	1027	0.56	1072	0.60	1113	0.63	1155	0.66	1198	0.69
1700	907	0.48	961	0.53	1013	0.58	1061	0.63	1105	0.67	1146	0.70	1187	0.73	1230	0.77
1800	948	0.56	999	0.61	1049	0.66	1096	0.71	1139	0.75	1180	0.78	1221	0.82	1262	0.86
1900	987	0.64	1037	0.69	1086	0.74	1132	0.79	1174	0.83	1214	0.86	1255	0.90	1295	0.95
2000	1028	0.73	1076	0.78	1123	0.83	1168	0.87	1210	0.91	1250	0.96	1289	1.00	1328	1.06

Air Volume cfm	External Static - in. w.g.															
	0.90		1.00		1.10		1.20		1.30		1.40		1.50		1.60	
	RPM	BHP	RPM	BHP	RPM	BHP	RPM	BHP	RPM	BHP	RPM	BHP	RPM	BHP	RPM	BHP
1200	1139	0.49	1187	0.52	1234	0.54	1276	0.58	1314	0.62	1350	0.66	1385	0.71	1421	0.75
1300	1161	0.54	1208	0.57	1254	0.60	1295	0.64	1332	0.69	1366	0.73	1401	0.78	1436	0.83
1400	1185	0.59	1232	0.63	1276	0.67	1315	0.71	1351	0.76	1384	0.81	1419	0.86	1454	0.90
1500	1212	0.66	1257	0.70	1299	0.74	1337	0.79	1371	0.84	1404	0.89	1438	0.94	1473	0.99
1600	1242	0.73	1284	0.77	1324	0.82	1360	0.88	1394	0.93	1426	0.99	1460	1.04	1495	1.08
1700	1272	0.81	1312	0.86	1350	0.92	1385	0.98	1418	1.04	1451	1.09	1485	1.14	1519	1.19
1800	1302	0.90	1341	0.96	1377	1.02	1411	1.08	1444	1.15	1477	1.20	1510	1.25	1544	1.30
1900	1334	1.01	1371	1.07	1406	1.13	1439	1.20	1471	1.26	1504	1.32	1537	1.37	1571	1.41
2000	1365	1.12	1401	1.19	1435	1.25	1468	1.32	1500	1.38	1532	1.44	1565	1.49	1598	1.53

**BLOWER DATA**

**ZHA060**

**BLOWER TABLE INCLUDES RESISTANCE FOR BASE UNIT ONLY WITH DRY INDOOR COIL AND AIR FILTERS IN PLACE.**

FOR ALL UNITS ADD:

1 - Any factory installed options air resistance (heat section, economizer, wet coil, etc.).

2 - Any field installed accessories air resistance (duct resistance, diffuser, etc.).

See page 25 for blower motors and drives and wet coil and options/accessory air resistance data.

**DOWNFLOW**

Air Volume cfm	External Static - in. w.g.															
	0.10		0.20		0.30		0.40		0.50		0.60		0.70		0.80	
	RPM	BHP	RPM	BHP	RPM	BHP	RPM	BHP	RPM	BHP	RPM	BHP	RPM	BHP	RPM	BHP
1600	764	0.35	822	0.39	880	0.42	936	0.46	991	0.51	1042	0.55	1091	0.60	1136	0.64
1700	801	0.40	857	0.44	913	0.48	968	0.52	1020	0.57	1070	0.61	1117	0.66	1162	0.71
1800	838	0.46	893	0.50	947	0.54	1000	0.58	1051	0.63	1099	0.68	1145	0.73	1188	0.78
1900	876	0.52	929	0.56	982	0.61	1033	0.65	1082	0.70	1129	0.75	1173	0.80	1215	0.85
2000	914	0.59	966	0.63	1017	0.68	1067	0.72	1115	0.77	1160	0.83	1203	0.88	1244	0.94
2100	953	0.66	1004	0.71	1054	0.76	1102	0.81	1148	0.86	1192	0.92	1233	0.98	1273	1.04
2200	993	0.74	1042	0.79	1090	0.85	1137	0.90	1181	0.96	1224	1.02	1264	1.09	1303	1.15
2300	1033	0.83	1081	0.89	1128	0.94	1173	1.01	1216	1.07	1257	1.14	1296	1.20	1334	1.27
2400	1074	0.93	1120	0.99	1166	1.05	1209	1.12	1251	1.19	1291	1.26	1329	1.33	1366	1.41

Air Volume cfm	External Static - in. w.g.															
	0.90		1.00		1.10		1.20		1.30		1.40		1.50		1.60	
	RPM	BHP	RPM	BHP	RPM	BHP	RPM	BHP	RPM	BHP	RPM	BHP	RPM	BHP	RPM	BHP
1600	1180	0.68	1222	0.72	1263	0.76	1303	0.80	1341	0.85	1378	0.90	1414	0.94	1449	0.99
1700	1204	0.75	1245	0.79	1285	0.84	1325	0.88	1362	0.93	1398	0.98	1434	1.03	1468	1.08
1800	1229	0.83	1270	0.87	1309	0.92	1347	0.97	1384	1.02	1420	1.07	1454	1.12	1488	1.17
1900	1256	0.91	1296	0.96	1334	1.01	1371	1.07	1407	1.12	1442	1.17	1476	1.23	1509	1.28
2000	1284	1.00	1322	1.06	1360	1.11	1396	1.17	1431	1.23	1465	1.28	1498	1.33	1531	1.38
2100	1312	1.10	1350	1.16	1386	1.22	1422	1.28	1456	1.34	1489	1.40	1521	1.45	1554	1.50
2200	1341	1.22	1378	1.28	1414	1.34	1448	1.41	1481	1.46	1513	1.52	1546	1.57	1578	1.62
2300	1371	1.34	1407	1.41	1442	1.47	1475	1.54	1507	1.59	1539	1.65	1571	1.70	1602	1.75
2400	1402	1.48	1436	1.55	1470	1.61	1503	1.67	1535	1.73	1566	1.79	1597	1.84	1628	1.89

**HORIZONTAL**

Air Volume cfm	External Static - in. w.g.															
	0.10		0.20		0.30		0.40		0.50		0.60		0.70		0.80	
	RPM	BHP	RPM	BHP	RPM	BHP	RPM	BHP	RPM	BHP	RPM	BHP	RPM	BHP	RPM	BHP
1600	783	0.38	844	0.41	902	0.44	957	0.48	1008	0.52	1056	0.56	1100	0.60	1142	0.64
1700	825	0.44	882	0.47	938	0.50	989	0.54	1038	0.57	1083	0.62	1126	0.66	1166	0.71
1800	866	0.50	921	0.53	973	0.56	1021	0.60	1067	0.64	1111	0.68	1152	0.73	1191	0.78
1900	907	0.56	959	0.59	1008	0.63	1054	0.66	1098	0.71	1139	0.75	1179	0.80	1217	0.86
2000	948	0.63	996	0.66	1042	0.70	1086	0.74	1128	0.78	1168	0.83	1207	0.89	1244	0.94
2100	987	0.70	1033	0.74	1077	0.78	1119	0.82	1159	0.87	1198	0.93	1235	0.99	1272	1.05
2200	1026	0.78	1070	0.82	1112	0.87	1152	0.92	1191	0.98	1228	1.03	1265	1.10	1301	1.16
2300	1064	0.88	1106	0.92	1147	0.97	1186	1.03	1223	1.09	1260	1.15	1295	1.22	1331	1.28
2400	1102	0.98	1143	1.03	1182	1.08	1220	1.15	1256	1.21	1292	1.28	1327	1.35	1362	1.42

Air Volume cfm	External Static - in. w.g.															
	0.90		1.00		1.10		1.20		1.30		1.40		1.50		1.60	
	RPM	BHP	RPM	BHP	RPM	BHP	RPM	BHP	RPM	BHP	RPM	BHP	RPM	BHP	RPM	BHP
1600	1183	0.68	1223	0.72	1263	0.76	1302	0.81	1340	0.86	1377	0.91	1413	0.95	1448	1.00
1700	1205	0.75	1245	0.79	1284	0.84	1322	0.89	1360	0.94	1396	0.99	1431	1.04	1465	1.09
1800	1230	0.83	1268	0.87	1306	0.92	1344	0.98	1380	1.03	1416	1.08	1450	1.13	1483	1.19
1900	1255	0.91	1292	0.96	1330	1.02	1367	1.07	1402	1.13	1437	1.18	1470	1.24	1503	1.29
2000	1281	1.00	1318	1.06	1355	1.12	1391	1.18	1425	1.23	1459	1.29	1492	1.35	1524	1.40
2100	1308	1.11	1345	1.17	1381	1.23	1416	1.29	1450	1.35	1482	1.41	1514	1.46	1546	1.52
2200	1337	1.23	1372	1.29	1408	1.35	1442	1.42	1475	1.47	1507	1.53	1538	1.59	1569	1.64
2300	1366	1.35	1401	1.42	1435	1.49	1469	1.55	1501	1.61	1532	1.67	1563	1.72	1594	1.77
2400	1396	1.49	1431	1.56	1464	1.63	1496	1.69	1528	1.75	1559	1.81	1589	1.86	1619	1.91

**BLOWER DATA**

**ZHB036**

**BLOWER TABLE INCLUDES RESISTANCE FOR BASE UNIT ONLY WITH DRY INDOOR COIL AND AIR FILTERS IN PLACE.**

FOR ALL UNITS ADD:

1 - Any factory installed options air resistance (heat section, economizer, wet coil, etc.).

2 - Any field installed accessories air resistance (duct resistance, diffuser, etc.).

See page 25 for blower motors and drives and wet coil and options/accessory air resistance data.

**DOWNFLOW**

Air Volume cfm	External Static - in. w.g.															
	0.10		0.20		0.30		0.40		0.50		0.60		0.70		0.80	
	RPM	BHP	RPM	BHP	RPM	BHP	RPM	BHP	RPM	BHP	RPM	BHP	RPM	BHP	RPM	BHP
900	562	0.11	621	0.13	685	0.16	752	0.18	818	0.21	883	0.24	944	0.27	1001	0.30
1000	584	0.13	644	0.16	707	0.18	773	0.21	838	0.24	901	0.27	960	0.3	1015	0.33
1100	609	0.16	669	0.18	732	0.21	796	0.24	860	0.27	921	0.30	978	0.34	1031	0.37
1200	635	0.19	696	0.21	758	0.24	821	0.27	883	0.31	942	0.34	997	0.38	1049	0.42
1300	664	0.22	725	0.25	786	0.28	848	0.31	908	0.35	965	0.39	1018	0.43	1068	0.47
1400	696	0.26	756	0.29	816	0.32	876	0.36	935	0.40	989	0.44	1041	0.48	1089	0.52
1500	729	0.30	788	0.33	848	0.37	906	0.41	962	0.45	1015	0.50	1065	0.54	1112	0.58

Air Volume cfm	External Static - in. w.g.															
	0.90		1.00		1.10		1.20		1.30		1.40		1.50		1.60	
	RPM	BHP	RPM	BHP	RPM	BHP	RPM	BHP	RPM	BHP	RPM	BHP	RPM	BHP	RPM	BHP
900	1053	0.32	1103	0.35	1149	0.38	1193	0.41	1234	0.43	1274	0.47	1312	0.50	1351	0.53
1000	1066	0.36	1114	0.39	1160	0.42	1204	0.45	1245	0.48	1284	0.51	1322	0.54	1361	0.58
1100	1081	0.40	1128	0.43	1173	0.46	1216	0.49	1257	0.53	1296	0.56	1334	0.60	1372	0.63
1200	1097	0.45	1144	0.48	1188	0.51	1231	0.54	1271	0.58	1310	0.62	1347	0.66	1385	0.69
1300	1115	0.50	1161	0.53	1204	0.56	1246	0.60	1286	0.64	1325	0.68	1362	0.72	1399	0.76
1400	1135	0.56	1179	0.59	1222	0.62	1264	0.66	1303	0.70	1341	0.75	1378	0.79	1415	0.83
1500	1157	0.62	1200	0.65	1242	0.69	1282	0.73	1321	0.77	1359	0.82	1396	0.86	1431	0.91

**HORIZONTAL**

Air Volume cfm	External Static - in. w.g.															
	0.10		0.20		0.30		0.40		0.50		0.60		0.70		0.80	
	RPM	BHP	RPM	BHP	RPM	BHP	RPM	BHP	RPM	BHP	RPM	BHP	RPM	BHP	RPM	BHP
900	560	0.16	624	0.18	692	0.20	761	0.21	830	0.23	896	0.25	956	0.27	1012	0.29
1000	583	0.18	647	0.20	715	0.22	783	0.24	850	0.25	914	0.27	972	0.30	1025	0.33
1100	609	0.20	673	0.22	740	0.24	808	0.26	873	0.28	934	0.31	990	0.34	1041	0.37
1200	637	0.23	702	0.25	769	0.27	835	0.29	898	0.32	956	0.35	1009	0.38	1058	0.41
1300	669	0.26	734	0.28	800	0.30	863	0.33	924	0.36	979	0.39	1030	0.43	1077	0.46
1400	704	0.29	768	0.32	832	0.35	894	0.37	951	0.41	1004	0.44	1052	0.48	1097	0.52
1500	742	0.33	805	0.36	867	0.39	925	0.42	980	0.46	1030	0.50	1076	0.54	1119	0.58

Air Volume cfm	External Static - in. w.g.															
	0.90		1.00		1.10		1.20		1.30		1.40		1.50		1.60	
	RPM	BHP	RPM	BHP	RPM	BHP	RPM	BHP	RPM	BHP	RPM	BHP	RPM	BHP	RPM	BHP
900	1064	0.32	1114	0.35	1162	0.38	1208	0.41	1251	0.45	1293	0.49	1333	0.52	1373	0.56
1000	1076	0.36	1124	0.39	1170	0.42	1216	0.46	1259	0.49	1300	0.53	1340	0.57	1379	0.61
1100	1089	0.40	1136	0.43	1181	0.46	1225	0.50	1268	0.54	1308	0.58	1347	0.62	1386	0.66
1200	1104	0.45	1150	0.48	1194	0.51	1237	0.55	1279	0.59	1319	0.63	1357	0.67	1394	0.71
1300	1121	0.5	1165	0.53	1209	0.57	1251	0.61	1292	0.65	1331	0.69	1368	0.73	1405	0.78
1400	1140	0.56	1183	0.59	1225	0.63	1266	0.67	1306	0.71	1345	0.76	1382	0.8	1417	0.85
1500	1161	0.62	1202	0.65	1243	0.69	1284	0.73	1323	0.78	1360	0.83	1396	0.87	1432	0.92

**BLOWER DATA**

**ZHB048**

**BLOWER TABLE INCLUDES RESISTANCE FOR BASE UNIT ONLY WITH DRY INDOOR COIL AND AIR FILTERS IN PLACE.**

FOR ALL UNITS ADD:

1 - Any factory installed options air resistance (heat section, economizer, wet coil, etc.).

2 - Any field installed accessories air resistance (duct resistance, diffuser, etc.).

See page 25 for blower motors and drives and wet coil and options/accessory air resistance data.

**DOWNFLOW**

Air Volume cfm	External Static - in. w.g.															
	0.10		0.20		0.30		0.40		0.50		0.60		0.70		0.80	
	RPM	BHP	RPM	BHP	RPM	BHP	RPM	BHP	RPM	BHP	RPM	BHP	RPM	BHP	RPM	BHP
1200	620	0.23	681	0.29	744	0.34	809	0.39	875	0.43	941	0.47	1004	0.51	1060	0.54
1300	652	0.28	713	0.34	775	0.39	839	0.44	903	0.48	967	0.51	1025	0.55	1078	0.59
1400	687	0.33	747	0.39	809	0.44	871	0.49	934	0.53	994	0.57	1048	0.61	1098	0.64
1500	724	0.40	784	0.45	844	0.50	905	0.54	965	0.59	1021	0.62	1071	0.66	1118	0.70
1600	764	0.46	823	0.51	882	0.56	940	0.60	997	0.65	1048	0.69	1094	0.72	1140	0.75
1700	806	0.53	863	0.58	919	0.62	975	0.67	1028	0.71	1075	0.75	1119	0.78	1164	0.81
1800	849	0.60	903	0.65	957	0.69	1010	0.74	1058	0.78	1102	0.82	1145	0.85	1189	0.88
1900	892	0.68	944	0.72	995	0.77	1045	0.82	1089	0.86	1131	0.89	1174	0.92	1217	0.95
2000	935	0.76	984	0.81	1033	0.86	1079	0.91	1122	0.95	1163	0.97	1204	1.00	1247	1.03

Air Volume cfm	External Static - in. w.g.															
	0.90		1.00		1.10		1.20		1.30		1.40		1.50		1.60	
	RPM	BHP	RPM	BHP	RPM	BHP	RPM	BHP	RPM	BHP	RPM	BHP	RPM	BHP	RPM	BHP
1200	1111	0.58	1156	0.60	1199	0.62	1241	0.63	1284	0.65	1326	0.67	1367	0.71	1408	0.74
1300	1127	0.62	1172	0.65	1214	0.66	1256	0.68	1299	0.70	1341	0.73	1381	0.77	1421	0.81
1400	1145	0.68	1189	0.70	1231	0.72	1274	0.74	1316	0.76	1357	0.79	1397	0.83	1436	0.88
1500	1164	0.73	1208	0.75	1251	0.78	1293	0.80	1334	0.83	1374	0.86	1413	0.91	1451	0.95
1600	1185	0.79	1229	0.81	1271	0.84	1313	0.86	1354	0.90	1393	0.94	1431	0.98	1468	1.03
1700	1208	0.84	1252	0.87	1294	0.90	1335	0.94	1375	0.98	1413	1.02	1449	1.07	1485	1.12
1800	1233	0.91	1276	0.94	1318	0.98	1358	1.02	1397	1.06	1434	1.11	1469	1.16	1504	1.21
1900	1261	0.98	1303	1.02	1343	1.06	1382	1.11	1420	1.16	1455	1.21	1490	1.26	1525	1.31
2000	1289	1.07	1330	1.11	1370	1.16	1407	1.21	1444	1.27	1478	1.32	1513	1.37	1547	1.42

**HORIZONTAL**

Air Volume cfm	External Static - in. w.g.															
	0.10		0.20		0.30		0.40		0.50		0.60		0.70		0.80	
	RPM	BHP	RPM	BHP	RPM	BHP	RPM	BHP	RPM	BHP	RPM	BHP	RPM	BHP	RPM	BHP
1200	614	0.21	681	0.25	752	0.30	821	0.34	888	0.39	950	0.43	1006	0.46	1057	0.49
1300	644	0.24	712	0.29	782	0.34	850	0.39	915	0.43	974	0.47	1027	0.51	1076	0.53
1400	677	0.29	746	0.34	814	0.39	880	0.44	942	0.48	998	0.52	1049	0.55	1097	0.58
1500	714	0.34	781	0.40	848	0.45	911	0.49	970	0.53	1023	0.57	1072	0.60	1119	0.63
1600	752	0.40	818	0.45	882	0.50	943	0.55	999	0.59	1050	0.62	1097	0.66	1142	0.69
1700	792	0.46	855	0.52	917	0.56	975	0.61	1028	0.64	1077	0.68	1123	0.72	1166	0.75
1800	832	0.53	894	0.58	952	0.63	1007	0.67	1058	0.70	1105	0.74	1149	0.78	1192	0.82
1900	873	0.60	932	0.65	988	0.69	1040	0.73	1088	0.77	1134	0.81	1177	0.85	1219	0.90
2000	914	0.67	970	0.72	1023	0.76	1073	0.80	1120	0.85	1163	0.89	1205	0.94	1246	0.99

Air Volume cfm	External Static - in. w.g.															
	0.90		1.00		1.10		1.20		1.30		1.40		1.50		1.60	
	RPM	BHP	RPM	BHP	RPM	BHP	RPM	BHP	RPM	BHP	RPM	BHP	RPM	BHP	RPM	BHP
1200	1105	0.51	1152	0.53	1197	0.55	1240	0.58	1280	0.61	1320	0.64	1358	0.68	1395	0.72
1300	1123	0.55	1169	0.57	1213	0.60	1255	0.63	1295	0.67	1334	0.70	1372	0.74	1409	0.79
1400	1142	0.60	1187	0.63	1230	0.66	1272	0.69	1312	0.73	1350	0.77	1388	0.82	1424	0.86
1500	1163	0.66	1207	0.69	1249	0.72	1290	0.76	1330	0.80	1368	0.85	1405	0.90	1441	0.94
1600	1185	0.72	1228	0.75	1270	0.79	1310	0.83	1349	0.88	1387	0.93	1423	0.98	1459	1.03
1700	1209	0.78	1251	0.82	1292	0.87	1331	0.92	1370	0.97	1407	1.02	1443	1.07	1478	1.12
1800	1234	0.86	1275	0.91	1315	0.96	1354	1.01	1391	1.06	1428	1.11	1463	1.17	1498	1.22
1900	1260	0.95	1300	1.00	1340	1.05	1377	1.11	1414	1.16	1450	1.22	1485	1.27	1519	1.32
2000	1287	1.04	1326	1.10	1365	1.16	1402	1.21	1437	1.27	1472	1.33	1507	1.38	1541	1.43

**BLOWER DATA**

**ZHB060**

**BLOWER TABLE INCLUDES RESISTANCE FOR BASE UNIT ONLY WITH DRY INDOOR COIL AND AIR FILTERS IN PLACE.**

FOR ALL UNITS ADD:

1 - Any factory installed options air resistance (heat section, economizer, wet coil, etc.).

2 - Any field installed accessories air resistance (duct resistance, diffuser, etc.).

See page 25 for blower motors and drives and wet coil and options/accessory air resistance data.

**DOWNFLOW**

Air Volume cfm	External Static - in. w.g.															
	0.10		0.20		0.30		0.40		0.50		0.60		0.70		0.80	
	RPM	BHP	RPM	BHP	RPM	BHP	RPM	BHP	RPM	BHP	RPM	BHP	RPM	BHP	RPM	BHP
1600	522	0.27	552	0.32	585	0.37	619	0.43	656	0.48	693	0.53	732	0.59	771	0.64
1700	539	0.32	570	0.37	603	0.43	638	0.48	674	0.53	711	0.59	749	0.64	787	0.69
1800	558	0.38	589	0.43	623	0.48	658	0.54	694	0.59	730	0.64	767	0.70	803	0.75
1900	578	0.44	610	0.49	643	0.54	678	0.60	714	0.65	749	0.70	785	0.76	819	0.82
2000	600	0.50	632	0.56	665	0.61	699	0.66	734	0.71	769	0.77	803	0.83	837	0.90
2100	623	0.57	655	0.62	688	0.68	721	0.73	755	0.79	789	0.84	822	0.91	854	0.98
2200	647	0.65	678	0.70	711	0.75	743	0.81	776	0.86	809	0.93	841	1.00	872	1.06
2300	671	0.73	702	0.78	734	0.83	766	0.89	798	0.95	829	1.02	860	1.09	890	1.16
2400	696	0.81	726	0.87	757	0.92	788	0.98	819	1.04	850	1.11	880	1.19	909	1.26

Air Volume cfm	External Static - in. w.g.															
	0.90		1.00		1.10		1.20		1.30		1.40		1.50		1.60	
	RPM	BHP	RPM	BHP	RPM	BHP	RPM	BHP	RPM	BHP	RPM	BHP	RPM	BHP	RPM	BHP
1600	809	0.69	844	0.74	877	0.80	908	0.85	936	0.91	963	0.97	989	1.02	1014	1.08
1700	823	0.75	857	0.80	889	0.86	919	0.92	947	0.97	973	1.03	999	1.09	1024	1.14
1800	838	0.81	870	0.87	901	0.92	931	0.98	958	1.04	984	1.10	1009	1.16	1034	1.22
1900	853	0.88	885	0.94	915	0.99	944	1.05	971	1.11	996	1.17	1021	1.23	1045	1.29
2000	869	0.96	899	1.01	929	1.07	957	1.13	984	1.19	1009	1.25	1033	1.31	1058	1.38
2100	885	1.04	915	1.10	944	1.15	971	1.22	997	1.28	1022	1.34	1046	1.40	1070	1.46
2200	902	1.13	931	1.19	959	1.24	986	1.31	1012	1.37	1036	1.43	1060	1.50	1084	1.56
2300	920	1.23	948	1.29	975	1.35	1001	1.41	1027	1.47	1051	1.53	1075	1.60	1098	1.66
2400	938	1.33	965	1.39	992	1.45	1017	1.52	1042	1.58	1066	1.64	1090	1.70	1113	1.77

**HORIZONTAL**

Air Volume cfm	External Static - in. w.g.															
	0.10		0.20		0.30		0.40		0.50		0.60		0.70		0.80	
	RPM	BHP	RPM	BHP	RPM	BHP	RPM	BHP	RPM	BHP	RPM	BHP	RPM	BHP	RPM	BHP
1600	525	0.30	561	0.34	597	0.39	635	0.43	673	0.47	711	0.51	748	0.56	784	0.61
1700	543	0.34	578	0.39	615	0.43	653	0.48	691	0.52	728	0.57	765	0.62	800	0.67
1800	561	0.39	597	0.44	635	0.49	672	0.53	710	0.58	746	0.63	782	0.68	816	0.73
1900	581	0.44	618	0.49	655	0.54	692	0.59	729	0.64	765	0.69	800	0.75	833	0.80
2000	602	0.50	639	0.55	676	0.61	713	0.66	749	0.71	784	0.76	818	0.82	850	0.88
2100	625	0.57	661	0.62	698	0.67	735	0.73	770	0.78	804	0.84	837	0.90	868	0.96
2200	648	0.64	685	0.69	721	0.75	757	0.80	791	0.86	824	0.92	856	0.98	886	1.05
2300	673	0.71	709	0.77	745	0.83	780	0.88	813	0.94	845	1.01	876	1.08	905	1.15
2400	699	0.79	734	0.85	769	0.91	803	0.97	835	1.04	866	1.11	896	1.18	924	1.25

Air Volume cfm	External Static - in. w.g.															
	0.90		1.00		1.10		1.20		1.30		1.40		1.50		1.60	
	RPM	BHP	RPM	BHP	RPM	BHP	RPM	BHP	RPM	BHP	RPM	BHP	RPM	BHP	RPM	BHP
1600	819	0.66	851	0.72	883	0.77	913	0.83	943	0.89	971	0.95	998	1.01	1024	1.07
1700	833	0.72	865	0.78	896	0.84	926	0.90	954	0.96	982	1.02	1009	1.08	1034	1.14
1800	848	0.79	880	0.85	910	0.92	939	0.98	967	1.04	994	1.10	1020	1.16	1045	1.23
1900	864	0.87	895	0.93	924	0.99	953	1.06	980	1.12	1007	1.18	1032	1.25	1056	1.31
2000	881	0.95	911	1.01	940	1.08	967	1.14	994	1.21	1020	1.27	1044	1.34	1068	1.40
2100	898	1.03	927	1.10	955	1.17	982	1.23	1008	1.30	1033	1.37	1057	1.43	1080	1.50
2200	916	1.12	944	1.19	971	1.26	998	1.33	1023	1.40	1047	1.47	1071	1.54	1093	1.60
2300	934	1.22	961	1.29	988	1.36	1014	1.43	1038	1.50	1062	1.58	1085	1.65	1107	1.71
2400	952	1.32	979	1.40	1005	1.47	1030	1.54	1054	1.62	1077	1.69	1099	1.76	1121	1.83

**BLOWER TABLE INCLUDES RESISTANCE FOR BASE UNIT ONLY WITH DRY INDOOR COIL AND AIR FILTERS IN PLACE.**

FOR ALL UNITS ADD:

1 - Any factory installed options air resistance (heat section, economizer, wet coil, etc.).

2 - Any field installed accessories air resistance (duct resistance, diffuser, etc.).

See page 25 for blower motors and drives and wet coil and options/accessory air resistance data.

**DOWNFLOW**

Air Volume cfm	External Static - in. w.g.															
	0.10		0.20		0.30		0.40		0.50		0.60		0.70		0.80	
	RPM	BHP	RPM	BHP	RPM	BHP	RPM	BHP	RPM	BHP	RPM	BHP	RPM	BHP	RPM	BHP
1800	558	0.38	589	0.43	623	0.48	658	0.54	694	0.59	730	0.64	767	0.70	803	0.75
1900	578	0.44	610	0.49	643	0.54	678	0.60	714	0.65	749	0.70	785	0.76	819	0.82
2000	600	0.50	632	0.56	665	0.61	699	0.66	734	0.71	769	0.77	803	0.83	837	0.90
2100	623	0.57	655	0.62	688	0.68	721	0.73	755	0.79	789	0.84	822	0.91	854	0.98
2200	647	0.65	678	0.70	711	0.75	743	0.81	776	0.86	809	0.93	841	1.00	872	1.06
2300	671	0.73	702	0.78	734	0.83	766	0.89	798	0.95	829	1.02	860	1.09	890	1.16
2400	696	0.81	726	0.87	757	0.92	788	0.98	819	1.04	850	1.11	880	1.19	909	1.26
2500	720	0.90	750	0.95	780	1.01	811	1.07	841	1.14	871	1.22	900	1.30	929	1.37
2600	745	0.99	774	1.05	804	1.11	834	1.17	864	1.25	893	1.33	921	1.41	949	1.49
2700	770	1.09	799	1.15	828	1.21	858	1.28	887	1.36	916	1.44	943	1.53	969	1.61
2800	795	1.19	824	1.25	853	1.33	882	1.40	911	1.48	939	1.56	965	1.65	990	1.73
2900	820	1.30	849	1.37	878	1.45	907	1.53	935	1.61	962	1.70	988	1.78	1012	1.86

Air Volume cfm	External Static - in. w.g.															
	0.90		1.00		1.10		1.20		1.30		1.40		1.50		1.60	
	RPM	BHP	RPM	BHP	RPM	BHP	RPM	BHP	RPM	BHP	RPM	BHP	RPM	BHP	RPM	BHP
1800	838	0.81	870	0.87	901	0.92	931	0.98	958	1.04	984	1.10	1009	1.16	1034	1.22
1900	853	0.88	885	0.94	915	0.99	944	1.05	971	1.11	996	1.17	1021	1.23	1045	1.29
2000	869	0.96	899	1.01	929	1.07	957	1.13	984	1.19	1009	1.25	1033	1.31	1058	1.38
2100	885	1.04	915	1.10	944	1.15	971	1.22	997	1.28	1022	1.34	1046	1.40	1070	1.46
2200	902	1.13	931	1.19	959	1.24	986	1.31	1012	1.37	1036	1.43	1060	1.50	1084	1.56
2300	920	1.23	948	1.29	975	1.35	1001	1.41	1027	1.47	1051	1.53	1075	1.60	1098	1.66
2400	938	1.33	965	1.39	992	1.45	1017	1.52	1042	1.58	1066	1.64	1090	1.70	1113	1.77
2500	956	1.44	983	1.51	1009	1.57	1034	1.63	1059	1.69	1082	1.75	1105	1.82	1128	1.88
2600	975	1.56	1001	1.63	1026	1.69	1051	1.75	1075	1.81	1098	1.87	1121	1.93	1143	2.00
2700	995	1.68	1020	1.75	1044	1.81	1069	1.87	1092	1.93	1114	1.99	1136	2.06	1158	2.13
2800	1015	1.81	1039	1.87	1063	1.94	1086	2.00	1109	2.06	1131	2.12	1152	2.19	1174	2.26
2900	1035	1.94	1058	2.00	1081	2.07	1104	2.13	1126	2.19	1147	2.26	1168	2.33	1189	2.40

**HORIZONTAL**

Air Volume cfm	External Static - in. w.g.															
	0.10		0.20		0.30		0.40		0.50		0.60		0.70		0.80	
	RPM	BHP	RPM	BHP	RPM	BHP	RPM	BHP	RPM	BHP	RPM	BHP	RPM	BHP	RPM	BHP
1800	561	0.39	597	0.44	635	0.49	672	0.53	710	0.58	746	0.63	782	0.68	816	0.73
1900	581	0.44	618	0.49	655	0.54	692	0.59	729	0.64	765	0.69	800	0.75	833	0.80
2000	602	0.50	639	0.55	676	0.61	713	0.66	749	0.71	784	0.76	818	0.82	850	0.88
2100	625	0.57	661	0.62	698	0.67	735	0.73	770	0.78	804	0.84	837	0.90	868	0.96
2200	648	0.64	685	0.69	721	0.75	757	0.80	791	0.86	824	0.92	856	0.98	886	1.05
2300	673	0.71	709	0.77	745	0.83	780	0.88	813	0.94	845	1.01	876	1.08	905	1.15
2400	699	0.79	734	0.85	769	0.91	803	0.97	835	1.04	866	1.11	896	1.18	924	1.25
2500	725	0.88	759	0.94	793	1.00	826	1.07	857	1.14	887	1.21	916	1.28	944	1.36
2600	752	0.97	785	1.04	818	1.10	850	1.17	880	1.25	909	1.32	937	1.40	964	1.48
2700	779	1.07	811	1.14	843	1.21	873	1.29	902	1.37	931	1.44	958	1.52	984	1.60
2800	805	1.18	837	1.26	868	1.33	897	1.41	925	1.49	952	1.57	979	1.66	1004	1.74
2900	832	1.30	863	1.38	892	1.46	921	1.54	948	1.63	974	1.71	1000	1.80	1024	1.88

Air Volume cfm	External Static - in. w.g.															
	0.90		1.00		1.10		1.20		1.30		1.40		1.50		1.60	
	RPM	BHP	RPM	BHP	RPM	BHP	RPM	BHP	RPM	BHP	RPM	BHP	RPM	BHP	RPM	BHP
1800	848	0.79	880	0.85	910	0.92	939	0.98	967	1.04	994	1.10	1020	1.16	1045	1.23
1900	864	0.87	895	0.93	924	0.99	953	1.06	980	1.12	1007	1.18	1032	1.25	1056	1.31
2000	881	0.95	911	1.01	940	1.08	967	1.14	994	1.21	1020	1.27	1044	1.34	1068	1.40
2100	898	1.03	927	1.10	955	1.17	982	1.23	1008	1.30	1033	1.37	1057	1.43	1080	1.50
2200	916	1.12	944	1.19	971	1.26	998	1.33	1023	1.40	1047	1.47	1071	1.54	1093	1.60
2300	934	1.22	961	1.29	988	1.36	1014	1.43	1038	1.50	1062	1.58	1085	1.65	1107	1.71
2400	952	1.32	979	1.40	1005	1.47	1030	1.54	1054	1.62	1077	1.69	1099	1.76	1121	1.83
2500	971	1.43	997	1.51	1022	1.59	1046	1.66	1069	1.74	1092	1.81	1114	1.88	1135	1.95
2600	990	1.55	1015	1.63	1039	1.71	1063	1.79	1086	1.86	1108	1.94	1129	2.01	1150	2.07
2700	1009	1.68	1034	1.76	1057	1.84	1080	1.92	1102	1.99	1124	2.07	1145	2.14	1166	2.21
2800	1028	1.82	1052	1.9	1075	1.98	1097	2.06	1119	2.13	1140	2.21	1161	2.28	1182	2.34
2900	1048	1.96	1071	2.04	1093	2.12	1115	2.20	1136	2.28	1157	2.35	1177	2.42	1198	2.48

## BLOWER DATA

### DRIVE KIT SPECIFICATIONS - ZHA036-060, ZHB036-048

Model No.	Motor HP		No. of Speeds	Drive Kits and RPM Range					
	Nominal	Maximum		ZA01	ZA02	ZA03	ZA04	<sup>3</sup> ZA05	<sup>3</sup> ZA06
ZHA/ZHB 036	<sup>1</sup> 0.75	0.86	1	678 - 1035	---	---	964 - 1471	---	---
	<sup>2</sup> 1	1.15	1	678 - 1035	---	---	964 - 1471	---	---
	<sup>1</sup> 1.5	1.7	1	678 - 1035	---	---	964 - 1471	---	---
ZHA/ZHB 048	<sup>1</sup> 0.75	0.86	1	---	803 - 1226	---	---	---	---
	<sup>2</sup> 1	1.15	1	---	803 - 1226	---	---	---	---
	<sup>1</sup> 1.5	1.7	1	---	803 - 1226	---	---	1098 - 1490	---
ZHA060	1	1.15	1	---	---	906 - 1383	---	---	---
	1.5	1.7	1	---	---	906 - 1383	---	---	1262 - 1634

### DRIVE KIT SPECIFICATIONS - ZHB060-072

Model No.	Motor HP		No. of Speeds	Drive Kits and RPM Range			
	Nominal	Maximum		ZAA01	ZAA02	<sup>3</sup> ZAA03	<sup>4</sup> ZAA04
ZHB060	<sup>1</sup> 0.75	0.86	1	522 - 784	632 - 875	---	---
	<sup>2</sup> 1	1.15	1	522 - 784	632 - 875	---	---
	1.5	1.7	1	522 - 784	632 - 875	798 - 1105	---
ZHB072	1	1.15	1	---	632 - 875	---	---
	1.5	1.7	1	---	632 - 875	798 - 1105	---
	2	2.3	1	---	632 - 875	798 - 1105	921 - 1228

NOTE - Using total air volume and system static pressure requirements determine from blower performance tables rpm and motor hp required. Maximum usable hp of motors furnished are shown. In Canada, nominal motor hp is also maximum usable motor hp. If motors of comparable hp are used, be sure to keep within the service factor limitations outlined on the motor nameplate.

<sup>1</sup> 0.75 and 1.5 hp motors are only available for ZHB036-060 208/230V-1ph applications.

<sup>2</sup> 1 hp blower motor is not available for ZHB060 208/230V-1ph applications.

<sup>3</sup> 1.5 hp blower motor is the minimum required with the ZA05, ZA06, and ZAA03 drive kits.

<sup>4</sup> 2 hp blower motor is required with the ZAA04 drive kit.

### POWER EXHAUST FAN PERFORMANCE

Return Air System Static Pressure - in. w.g.	Air Volume Exhausted cfm
0.00	1865
0.05	1785
0.10	1710
0.15	1630
0.20	1545
0.25	1450
0.30	1350
0.35	1240

## BLOWER DATA

### OPTIONS / ACCESSORIES AIR RESISTANCE - in. w.g.

Air Volume cfm	Wet Indoor Coil				Electric Heat	Economizer	
	ZHA036, ZHA048	ZHA060, ZHB036	ZHB048, ZHB060	ZHB072		Downflow	Horizontal
900	0.01	0.01	---	---	0.05	0.03	0.04
1000	0.02	0.01	---	---	0.06	0.03	0.05
1100	0.02	0.02	---	---	0.08	0.04	0.05
1200	0.02	0.02	0.01	---	0.09	0.05	0.06
1300	0.03	0.02	0.02	---	0.12	0.05	0.07
1400	0.03	0.03	0.02	---	0.17	0.06	0.08
1500	0.04	0.03	0.02	---	0.22	0.07	0.08
1600	0.04	0.03	0.03	0.03	0.26	0.08	0.09
1700	0.05	0.04	0.03	0.03	0.30	0.09	0.10
1800	0.05	0.04	0.03	0.03	0.33	0.10	0.11
1900	0.06	0.05	0.04	0.04	0.33	0.11	0.12
2000	0.06	0.05	0.04	0.04	0.31	0.12	0.13
2100	---	0.06	0.05	0.05	0.27	0.13	0.14
2200	---	0.06	0.05	0.05	0.29	0.14	0.15
2300	---	0.07	0.05	0.05	0.31	0.15	0.16
2400	---	0.07	0.06	0.06	0.32	0.16	0.18
2500	---	---	---	0.06	0.34	0.18	0.19
2600	---	---	---	0.07	0.38	0.19	0.20
2700	---	---	---	0.07	0.42	0.20	0.21
2800	---	---	---	0.07	0.45	0.22	0.23
2900	---	---	---	0.08	0.49	0.23	0.24

## BLOWER DATA

### CEILING DIFFUSERS AIR RESISTANCE (in. w.g.)

Air Volume cfm	RTD9-65S Step-Down Diffuser			FD9-65S Flush Diffuser	RTD11-95S Step-Down Diffuser			FD11-95S Flush Diffuser
	2 Ends Open	1 Side & 2 Ends Open	All Ends & Sides Open		2 Ends Open	1 Side & 2 Ends Open	All Ends & Sides Open	
800	0.15	0.13	0.11	0.11	---	---	---	---
1000	0.19	0.16	0.14	0.14	---	---	---	---
1200	0.25	0.20	0.17	0.17	---	---	---	---
1400	0.33	0.26	0.20	0.20	---	---	---	---
1600	0.43	0.32	0.20	0.24	---	---	---	---
1800	0.56	0.40	0.30	0.30	0.13	0.11	0.09	0.09
2000	0.73	0.50	0.36	0.36	0.15	0.13	0.11	0.10
2200	0.95	0.63	0.44	0.44	0.18	0.15	0.12	0.12
2400	---	----	---	---	0.21	0.18	0.15	0.14
2600	---	----	---	---	0.24	0.21	0.18	0.17
2800	---	----	---	---	0.27	0.24	0.21	0.20
3000	---	----	---	---	0.32	0.29	0.25	0.25
3200	---	----	---	---	0.41	0.37	0.32	0.31
3400	---	----	---	---	0.50	0.45	0.39	0.37
3600	---	----	---	---	0.61	0.54	0.48	0.44

### CEILING DIFFUSER AIR THROW DATA

Air Volume - cfm	<sup>1</sup> Effective Throw - ft.	
Model No.	RTD9-65S	FD9-65S
800	10 - 17	14 - 18
1000	10 - 17	15 - 20
1200	11 - 18	16 - 22
1400	12 - 19	17 - 24
1600	12 - 20	18 - 25
1800	13 - 21	20 - 28
2000	14 - 23	21 - 29
2200	16 - 25	22 - 30
Model No.	RTD11-95S	FD11-95S
2600	24 - 29	19 - 24
2800	25 - 30	20 - 28
3000	27 - 33	21 - 29
3200	28 - 35	22 - 29
3400	30 - 37	22 - 30
3600	25 - 33	22 - 24

<sup>1</sup> Effective throw based on terminal velocities of 75 ft. per minute.

**ELECTRICAL/ELECTRIC HEAT DATA**

**3 TON**

Model No.		ZHA036S4					
<sup>1</sup> Voltage - 60hz		208/230V - 3 Ph		460V - 3 Ph		575V - 3 Ph	
Compressor	Rated Load Amps	8.7		4		3.6	
	Locked Rotor Amps	70		31		27	
Outdoor Fan Motor	Full Load Amps	1.7		0.9		0.7	
Power Exhaust (1) 0.5 HP	Full Load Amps	1.5		0.6		0.6	
Indoor Blower Motor	Horsepower	1	1.5	1	1.5	1	1.5
	Full Load Amps	4.6	6.6	2.1	3	1.7	2.4
<sup>2</sup> Maximum Overcurrent Protection	Unit Only	25	25	15	15	15	15
	With (1) 0.5 HP Power Exhaust	25	25	15	15	15	15
<sup>3</sup> Minimum Circuit Ampacity	Unit Only	18	20	8	9	7	8
	With (1) 0.5 HP Power Exhaust	19	21	9	10	8	9

**ELECTRIC HEAT DATA**

Electric Heat Voltage			208V	240V	208V	240V	480V	480V	600V	600V
<sup>2</sup> Maximum Overcurrent Protection	Unit+ Electric Heat	5 kW	35	35	35	35	20	20	15	15
		7.5 kW	40	40	40	45	20	25	20	20
		10 kW	45	50	50	50	25	25	20	20
		15 kW	60	70	60	70	35	35	25	30
<sup>3</sup> Minimum Circuit Ampacity	Unit+ Electric Heat	5 kW	31	33	33	35	16	17	13	14
		7.5 kW	37	40	39	42	20	21	16	17
		10 kW	44	48	46	50	24	24	19	20
		15 kW	57	63	59	65	31	32	25	26
<sup>2</sup> Maximum Overcurrent Protection	Unit+ Electric Heat and (1) 0.5 HP Power Exhaust	5 kW	35	35	35	40	20	20	15	15
		7.5 kW	40	45	45	45	20	25	20	20
		10 kW	45	50	50	60	25	25	20	25
		15 kW	60	70	60	70	35	35	30	30
<sup>3</sup> Minimum Circuit Ampacity	Unit+ Electric Heat and (1) 0.5 HP Power Exhaust	5 kW	32	34	34	36	17	18	14	15
		7.5 kW	39	42	41	44	20	21	17	18
		10 kW	45	49	47	51	24	25	20	21
		15 kW	58	64	60	66	32	33	26	27

**ELECTRIC HEAT ACCESSORIES**

Unit Fuse Block	Unit Only	10A27	10A27	10A29	10A29
	Unit + Power Exhaust	10A27	10A27	10A29	10A29

NOTE - All units have a minimum Short Circuit Current Rating (SCCR) of 5000 amps.

<sup>1</sup> Extremes of operating range are plus and minus 10% of line voltage.

<sup>2</sup> HACR type breaker or fuse.

<sup>3</sup> Refer to National or Canadian Electrical Code manual to determine wire, fuse and disconnect size requirements.

**ELECTRICAL/ELECTRIC HEAT DATA**

**4 TON**

Model No.		ZHA048S4					
<sup>1</sup> Voltage - 60hz		208/230V - 3 Ph		460V - 3 Ph		575V - 3 Ph	
Compressor	Rated Load Amps	11		5.5		4.7	
	Locked Rotor Amps	86		37		34	
Outdoor Fan Motor	Full Load Amps	1.7		0.9		0.7	
Power Exhaust (1) 0.5 HP	Full Load Amps	1.5		0.6		0.6	
Indoor Blower Motor	Horsepower	1	1.5	1	1.5	1	1.5
	Full Load Amps	4.6	6.6	2.1	3	1.7	2.4
<sup>2</sup> Maximum Overcurrent Protection	Unit Only	30	30	15	15	15	15
	With (1) 0.5 HP Power Exhaust	30	30	15	15	15	15
<sup>3</sup> Minimum Circuit Ampacity	Unit Only	21	23	10	11	9	9
	With (1) 0.5 HP Power Exhaust	22	24	11	12	9	10

**ELECTRIC HEAT DATA**

Electric Heat Voltage			208V	240V	208V	240V	480V	480V	600V	600V
<sup>2</sup> Maximum Overcurrent Protection	Unit+ Electric Heat	5 kW	40	40	40	45	20	20	15	15
		7.5 kW	45	45	45	50	25	25	20	20
		10 kW	50	60	50	60	25	30	25	25
		15 kW	60	70	70	70	35	35	30	30
		22.5 kW	80	90	90	90	45	45	40	40
<sup>3</sup> Minimum Circuit Ampacity	Unit+ Electric Heat	5 kW	34	36	36	38	18	19	15	15
		7.5 kW	40	43	42	45	22	23	18	18
		10 kW	47	51	49	53	25	26	21	22
		15 kW	60	66	62	68	33	34	27	28
		22.5 kW	79	88	81	90	44	45	36	37
<sup>2</sup> Maximum Overcurrent Protection	Unit+ Electric Heat and (1) 0.5 HP Power Exhaust	5 kW	40	40	40	45	20	20	15	20
		7.5 kW	45	50	50	50	25	25	20	20
		10 kW	50	60	50	60	30	30	25	25
		15 kW	70	70	70	70	35	35	30	30
			90	90	90	100	45	50	40	40
<sup>3</sup> Minimum Circuit Ampacity	Unit+ Electric Heat and (1) 0.5 HP Power Exhaust	5 kW	35	37	37	39	18	19	15	16
		7.5 kW	42	45	44	47	22	23	18	19
		10 kW	48	52	50	54	26	27	21	22
		15 kW	61	67	63	69	34	34	27	28
		22.5 kW	81	90	83	92	45	46	36	37

**ELECTRIC HEAT ACCESSORIES**

Unit Fuse Block	Unit Only	10A27	10A27	10A29	10A29
	Unit + Power Exhaust	10A27	10A27	10A29	10A29

NOTE - All units have a minimum Short Circuit Current Rating (SCCR) of 5000 amps.

<sup>1</sup> Extremes of operating range are plus and minus 10% of line voltage.

<sup>2</sup> HACR type breaker or fuse.

<sup>3</sup> Refer to National or Canadian Electrical Code manual to determine wire, fuse and disconnect size requirements.

**ELECTRICAL/ELECTRIC HEAT DATA**

**5 TON**

Model No.		ZHA060S4					
<sup>1</sup> Voltage - 60hz		208/230V - 3 Ph		460V - 3 Ph		575V - 3 Ph	
Compressor	Rated Load Amps	13.5		8		5	
	Locked Rotor Amps	109		59		40	
Outdoor Fan Motor	Full Load Amps	1.7		1		0.9	
Power Exhaust (1) 0.5 HP	Full Load Amps	1.5		0.6		0.6	
Indoor Blower Motor	Horsepower	1	1.5	1	1.5	1	1.5
	Full Load Amps	4.6	6.6	2.1	3	1.7	2.4
<sup>2</sup> Maximum Overcurrent Protection	Unit Only	35	35	20	20	15	15
	With (1) 0.5 HP Power Exhaust	35	40	20	20	15	15
<sup>3</sup> Minimum Circuit Ampacity	Unit Only	24	26	14	14	9	10
	With (1) 0.5 HP Power Exhaust	25	27	14	15	10	11

**ELECTRIC HEAT DATA**

Electric Heat Voltage			208V	240V	208V	240V	480V	480V	600V	600V
<sup>2</sup> Maximum Overcurrent Protection	Unit+ Electric Heat	5 kW	45	45	45	50	25	25	15	20
		7.5 kW	50	50	50	50	30	30	20	20
		10 kW	50	60	60	60	30	30	25	25
		15 kW	70	70	70	80	40	40	30	30
		22.5 kW	90	100	90	100	50	50	40	40
<sup>3</sup> Minimum Circuit Ampacity	Unit+ Electric Heat	5 kW	37	39	39	41	21	22	15	16
		7.5 kW	43	46	45	48	25	26	18	19
		10 kW	50	54	52	56	29	30	21	22
		15 kW	63	69	65	71	36	37	27	28
		22.5 kW	82	91	84	93	47	48	36	37
<sup>2</sup> Maximum Overcurrent Protection	Unit+ Electric Heat and (1) 0.5 HP Power Exhaust	5 kW	45	50	50	50	25	25	20	20
		7.5 kW	50	50	50	50	30	30	20	20
		10 kW	60	60	60	60	30	30	25	25
		15 kW	70	70	70	80	40	40	30	30
		22.5 kW	90	100	90	100	50	50	40	40
<sup>3</sup> Minimum Circuit Ampacity	Unit+ Electric Heat and (1) 0.5 HP Power Exhaust	5 kW	38	40	40	42	22	23	16	17
		7.5 kW	45	48	47	50	25	26	19	20
		10 kW	51	55	53	57	29	30	22	23
		15 kW	64	70	66	72	37	38	28	29
		22.5 kW	84	93	86	95	48	49	37	38

**ELECTRIC HEAT ACCESSORIES**

Unit Fuse Block	Unit Only	10A28	10A28	10A29	10A29
	Unit + Power Exhaust	10A28	10A28	10A29	10A29

NOTE - All units have a minimum Short Circuit Current Rating (SCCR) of 5000 amps.

<sup>1</sup> Extremes of operating range are plus and minus 10% of line voltage.

<sup>2</sup> HACR type breaker or fuse.

<sup>3</sup> Refer to National or Canadian Electrical Code manual to determine wire, fuse and disconnect size requirements.

**ELECTRICAL/ELECTRIC HEAT DATA**

**3 TON**

Model No.		ZHB036S4							
<sup>1</sup> Voltage - 60hz		208/230V - 1 Ph		208/230V - 3 Ph		460V - 3 Ph		575V - 3 Ph	
Compressor	Rated Load Amps	15.3		8.7		4		3.6	
	Locked Rotor Amps	70		70		31		27	
Outdoor Fan Motor	Full Load Amps	1		1		0.6		0.45	
Power Exhaust (1) 0.5 HP	Full Load Amps	1.5		1.5		0.6		0.6	
Indoor Blower Motor	Horsepower	0.75	1.5	1	1.5	1	1.5	1	1.5
	Full Load Amps	7.6	11	4.6	6.6	2.1	3	1.7	2.4
<sup>2</sup> Maximum Overcurrent Protection	Unit Only	40	45	25	25	15	15	15	15
	With (1) 0.5 HP Power Exhaust	40	45	25	25	15	15	15	15
<sup>3</sup> Minimum Circuit Ampacity	Unit Only	28	32	17	19	8	9	7	8
	With (1) 0.5 HP Power Exhaust	30	33	18	20	9	10	8	8

**ELECTRIC HEAT DATA**

Electric Heat Voltage			208	240	208	240	240	240	480	480	600	600
<sup>2</sup> Maximum Overcurrent Protection	Unit+ Electric Heat	5 kW	60	60	60	60	35	35	15	20	15	15
		7.5 kW	70	70	70	80	40	45	20	20	20	20
		10 kW	80	80	80	90	50	50	25	25	20	20
		15 kW	100	110	100	110	70	70	30	35	25	30
<sup>3</sup> Minimum Circuit Ampacity	Unit+ Electric Heat	5 kW	51	54	54	58	32	34	15	17	13	14
		7.5 kW	62	67	65	71	40	42	19	20	16	17
		10 kW	73	80	77	84	47	49	23	24	19	20
		15 kW	96	106	99	110	62	64	30	32	25	26
<sup>2</sup> Maximum Overcurrent Protection	Unit+ Electric Heat and (1) 0.5 HP Power Exhaust	5 kW	60	60	60	60	35	40	20	20	15	15
		7.5 kW	70	70	70	80	45	45	20	25	20	20
		10 kW	80	90	80	90	50	60	25	25	20	20
		15 kW	100	110	110	125	70	70	35	35	25	30
<sup>3</sup> Minimum Circuit Ampacity	Unit+ Electric Heat and (1) 0.5 HP Power Exhaust	5 kW	52	56	56	59	34	36	16	17	13	14
		7.5 kW	64	69	67	72	41	43	20	21	16	17
		10 kW	75	82	78	85	49	51	23	25	19	20
		15 kW	97	108	101	111	64	66	31	32	25	26

**ELECTRIC HEAT ACCESSORIES**

Unit Fuse Block	Unit Only	10A26	10A26	10A27	10A29	10A29
	Unit + Power Exhaust	10A26	10A26	10A27	10A29	10A29

NOTE - All units have a minimum Short Circuit Current Rating (SCCR) of 5000 amps.

<sup>1</sup> Extremes of operating range are plus and minus 10% of line voltage.

<sup>2</sup> HACR type breaker or fuse.

<sup>3</sup> Refer to National or Canadian Electrical Code manual to determine wire, fuse and disconnect size requirements.

**ELECTRICAL/ELECTRIC HEAT DATA**

**4 TON**

Model No.		ZHB048S4							
<sup>1</sup> Voltage - 60hz		208/230V - 1 Ph		208/230V - 3 Ph		460V - 3 Ph		575V - 3 Ph	
Compressor	Rated Load Amps	20		11		5.5		4.7	
	Locked Rotor Amps	99		86		37		34	
Outdoor Fan Motor	Full Load Amps	1.7		1.7		0.9		0.7	
Power Exhaust (1) 0.5 HP	Full Load Amps	1.5		1.5		0.6		0.6	
Indoor Blower Motor	Horsepower	0.75	1.5	1	1.5	1	1.5	1	1.5
	Full Load Amps	7.6	11	4.6	6.6	2.1	3	1.7	2.4
<sup>2</sup> Maximum Overcurrent Protection	Unit Only	50	50	30	30	15	15	15	15
	With (1) 0.5 HP Power Exhaust	50	50	30	30	15	15	15	15
<sup>3</sup> Minimum Circuit Ampacity	Unit Only	35	38	21	23	10	11	9	9
	With (1) 0.5 HP Power Exhaust	36	40	22	24	11	12	9	10

**ELECTRIC HEAT DATA**

Electric Heat Voltage			208	240	208	240	208	240	208	240	480	480	600	600
<sup>2</sup> Maximum Overcurrent Protection	Unit+ Electric Heat	5 kW	70	70	70	70	40	40	40	45	20	20	15	15
		7.5 kW	80	80	80	80	45	45	45	50	25	25	20	20
		10 kW	90	90	90	90	50	60	50	60	25	30	25	25
		15 kW	110	125	110	125	60	70	70	70	35	35	30	30
		22 kW	150	175	150	175	80	90	90	90	45	45	40	40
<sup>3</sup> Minimum Circuit Ampacity	Unit+ Electric Heat	5 kW	57	61	61	64	34	36	36	38	18	19	15	15
		7.5 kW	69	74	72	77	40	43	42	45	22	23	18	18
		10 kW	80	87	83	90	47	51	49	53	25	26	21	22
		15 kW	103	113	106	116	60	66	62	68	33	34	27	28
		22 kW	136	152	140	155	79	88	81	90	44	45	36	37
<sup>2</sup> Maximum Overcurrent Protection	Unit+ Electric Heat and (1) 0.5 HP Power Exhaust	5 kW	70	70	70	80	40	40	40	45	20	20	15	20
		7.5 kW	80	80	80	90	45	50	50	50	25	25	20	20
		10 kW	90	90	90	100	50	60	50	60	30	30	25	25
		15 kW	110	125	110	125	70	70	70	70	35	35	30	30
		22 kW	150	175	150	175	90	90	90	100	45	50	40	40
<sup>3</sup> Minimum Circuit Ampacity	Unit+ Electric Heat and (1) 0.5 HP Power Exhaust	5 kW	59	62	62	66	35	37	37	39	18	19	15	16
		7.5 kW	70	75	74	79	42	45	44	47	22	23	18	19
		10 kW	81	88	85	92	48	52	50	54	26	27	21	22
		15 kW	104	114	107	118	61	67	63	69	34	34	27	28
		22 kW	138	153	141	157	81	90	83	92	45	46	36	37

**ELECTRIC HEAT ACCESSORIES**

Unit Fuse Block	Unit Only	10A26	10A26	10A27	10A27	10A29	10A29
	Unit + Power Exhaust	10A26	10A26	10A27	10A27	10A29	10A29

NOTE - All units have a minimum Short Circuit Current Rating (SCCR) of 5000 amps.

<sup>1</sup> Extremes of operating range are plus and minus 10% of line voltage.

<sup>2</sup> HACR type breaker or fuse.

<sup>3</sup> Refer to National or Canadian Electrical Code manual to determine wire, fuse and disconnect size requirements.

**ELECTRICAL/ELECTRIC HEAT DATA**

**5 TON**

Model No.		ZHB060S4							
<sup>1</sup> Voltage - 60hz		208/230V - 1 Ph		208/230V - 3 Ph		460V - 3 Ph		575V - 3 Ph	
Compressor	Rated Load Amps	22.1		13.5		8		5	
	Locked Rotor Amps	125		109		59		40	
Outdoor Fan Motor	Full Load Amps	1.7		1.7		1		0.9	
Power Exhaust (1) 0.5 HP	Full Load Amps	1.5		1.5		0.6		0.6	
Indoor Blower Motor	Horsepower	0.75	1.5	1	1.5	1	1.5	1	1.5
	Full Load Amps	7.6	11	4.6	6.6	2.1	3	1.7	2.4
<sup>2</sup> Maximum Overcurrent Protection	Unit Only	50	60	35	35	20	20	15	15
	With (1) 0.5 HP Power Exhaust	60	60	35	40	20	20	15	15
<sup>3</sup> Minimum Circuit Ampacity	Unit Only	37	41	24	26	14	14	9	10
	With (1) 0.5 HP Power Exhaust	39	42	25	27	14	15	10	11

**ELECTRIC HEAT DATA**

Electric Heat Voltage			208	240	208	240	208	240	208	240	480	480	600	600
<sup>2</sup> Maximum Overcurrent Protection	Unit+ Electric Heat	5 kW	70	70	80	80	45	45	45	50	25	25	15	20
		7.5 kW	80	90	80	90	50	50	50	50	25	30	20	20
		10 kW	90	100	90	100	50	60	60	60	30	30	25	25
		15 kW	110	125	110	125	70	70	70	80	40	40	30	30
		22 kW	150	175	150	175	90	90	90	100	50	50	40	40
<sup>3</sup> Minimum Circuit Ampacity	Unit+ Electric Heat	5 kW	60	63	63	67	36	38	39	41	21	22	15	16
		7.5 kW	71	76	75	80	42	45	45	48	24	26	18	19
		10 kW	83	90	86	93	49	53	52	56	28	30	21	22
		15 kW	105	116	109	119	62	68	65	71	36	37	27	28
		22 kW	139	155	142	158	81	90	84	93	47	48	36	37
<sup>2</sup> Maximum Overcurrent Protection	Unit+ Electric Heat and (1) 0.5 HP Power Exhaust	5 kW	70	80	80	80	45	45	50	50	25	25	20	20
		7.5 kW	80	90	90	90	50	50	50	50	30	30	20	20
		10 kW	90	100	100	100	50	60	60	60	30	30	25	25
		15 kW	110	125	110	125	70	70	70	80	40	40	30	30
		22 kW	150	175	150	175	90	100	90	100	50	50	40	40
<sup>3</sup> Minimum Circuit Ampacity	Unit+ Electric Heat and (1) 0.5 HP Power Exhaust	5 kW	61	65	65	68	37	39	40	42	21	23	16	17
		7.5 kW	73	78	76	81	44	47	47	50	25	26	19	20
		10 kW	84	91	87	94	50	54	53	57	29	30	22	23
		15 kW	107	117	110	120	63	69	66	72	36	38	28	29
		22 kW	140	156	144	160	83	92	86	95	48	49	37	38

**ELECTRIC HEAT ACCESSORIES**

Unit Fuse Block	Unit Only	10A26	10A26	10A28	10A28	10A29	10A29
	Unit + Power Exhaust	10A26	10A26	10A28	10A28	10A29	10A29

NOTE - All units have a minimum Short Circuit Current Rating (SCCR) of 5000 amps.

<sup>1</sup> Extremes of operating range are plus and minus 10% of line voltage.

<sup>2</sup> HACR type breaker or fuse.

<sup>3</sup> Refer to National or Canadian Electrical Code manual to determine wire, fuse and disconnect size requirements.

**ELECTRICAL/ELECTRIC HEAT DATA**

**6 TON**

Model No.		ZHB072S4								
<sup>1</sup> Voltage - 60hz		208/230V - 3 Ph			460V - 3 Ph			575V - 3 Ph		
Compressor	Rated Load Amps	22.4			10.6			7.7		
	Locked Rotor Amps	149			75			54		
Outdoor Fan Motor	Full Load Amps	2.4			1.3			1		
Power Exhaust (1) 0.5 HP	Full Load Amps	1.5			0.6			0.6		
Indoor Blower Motor	Horsepower	1	1.5	2	1	1.5	2	1	1.5	2
	Full Load Amps	4.6	6.6	7.5	2.1	3	3.4	1.7	2.4	2.7
<sup>2</sup> Maximum Overcurrent Protection	Unit Only	50	50	60	25	25	25	20	20	20
	With (1) 0.5 HP Power Exhaust	50	60	60	25	25	25	20	20	20
<sup>3</sup> Minimum Circuit Ampacity	Unit Only	35	37	38	17	18	18	13	14	14
	With (1) 0.5 HP Power Exhaust	37	39	40	18	19	19	13	14	14

**ELECTRIC HEAT DATA**

Electric Heat Voltage			208	240	208	240	208	240	480	480	480	600	600	600
<sup>2</sup> Maximum Overcurrent Protection	Unit+ Electric Heat	7.5 kW	70	70	70	70	70	70	35	35	35	25	25	25
		10 kW	70	80	80	80	80	80	35	40	40	25	30	30
		15 kW	80	90	90	90	90	90	45	45	45	35	35	35
		22 kW	100	110	100	110	100	110	60	60	60	40	45	45
		30 kW	125	150	125	150	125	150	70	70	70	50	50	50
<sup>3</sup> Minimum Circuit Ampacity	Unit+ Electric Heat	7.5 kW	55	58	57	60	58	61	28	29	30	22	23	23
		10 kW	62	66	64	68	64	68	32	33	33	25	26	26
		15 kW	75	81	77	83	77	84	40	41	41	31	32	32
		22 kW	94	103	96	105	97	106	51	52	52	40	41	41
		30 kW	114	126	116	128	117	129	62	63	64	49	50	50
<sup>2</sup> Maximum Overcurrent Protection	Unit+ Electric Heat and (1) 0.5 HP Power Exhaust	7.5 kW	70	70	70	70	70	70	35	35	35	25	25	25
		10 kW	70	80	80	80	80	80	35	40	40	30	30	30
		15 kW	90	90	90	90	90	90	45	45	45	35	35	35
		22 kW	100	110	100	110	100	110	60	60	60	40	45	45
		30 kW	125	150	125	150	125	150	70	70	70	50	50	60
<sup>3</sup> Minimum Circuit Ampacity	Unit+ Electric Heat and (1) 0.5 HP Power Exhaust	7.5 kW	57	60	59	62	59	62	29	30	30	22	23	23
		10 kW	63	67	65	69	66	70	33	34	34	25	26	26
		15 kW	76	82	78	84	79	85	40	41	42	31	32	32
		22 kW	96	105	98	107	99	108	52	52	53	40	41	41
		30 kW	115	127	117	129	118	130	63	64	64	50	50	51

**ELECTRIC HEAT ACCESSORIES**

Unit Fuse Block	Unit Only	<b>10A28</b>	<b>10A28</b>	<b>10A28</b>	<b>10A29</b>	<b>10A29</b>
	Unit + Power Exhaust	<b>10A28</b>	<b>10A28</b>	<b>10A28</b>	<b>10A29</b>	<b>10A29</b>

NOTE - All units have a minimum Short Circuit Current Rating (SCCR) of 5000 amps.

<sup>1</sup> Extremes of operating range are plus and minus 10% of line voltage.

<sup>2</sup> HACR type breaker or fuse.

<sup>3</sup> Refer to National or Canadian Electrical Code manual to determine wire, fuse and disconnect size requirements.

## ELECTRIC HEAT CAPACITIES

Input Voltage	5 kW			7.5 kW			10 kW		
	No of Stages	kW input	Btuh Output	No of Stages	kW input	Btuh Output	No of Stages	kW input	Btuh Output
208	1	3.8	12,800	1	5.6	19,200	1	7.5	25,600
220	1	4.2	14,300	1	6.3	21,500	1	8.4	28,700
230	1	4.6	15,700	1	6.9	23,500	1	9.2	31,400
240	1	5.0	17,100	1	7.5	25,600	1	10.0	34,200
440	1	4.2	14,300	1	6.3	21,500	1	8.4	28,700
460	1	4.6	15,700	1	6.9	23,500	1	9.2	31,400
480	1	5.0	17,100	1	7.5	25,600	1	10.0	34,200
550	1	4.2	14,300	1	6.3	21,500	1	8.4	28,700
575	1	4.6	15,700	1	6.9	23,500	1	9.2	31,400
600	1	5.0	17,100	1	7.5	25,600	1	10.0	34,200
Input Voltage	15 kW			22.5 kW			30 kW		
	No of Stages	kW input	Btuh Output	No of Stages	kW input	Btuh Output	No of Stages	kW input	Btuh Output
208	1	11.2	38,400	1	16.9	57,700	1	22.5	76,800
220	1	12.6	43,000	1	18.9	64,500	1	25.2	86,000
230	1	13.8	47,000	1	20.7	70,700	1	27.5	93,900
240	1	15.0	51,200	1	22.5	76,800	1	30.0	102,400
440	1	12.6	43,000	1	18.9	64,500	1	25.2	86,000
460	1	13.8	47,000	1	20.7	70,700	1	27.5	93,900
480	1	15.0	51,200	1	22.5	76,800	1	30.0	102,400
550	1	12.6	43,000	1	18.9	64,500	1	25.2	86,000
575	1	13.8	47,000	1	20.7	70,700	1	27.5	93,900
600	1	15.0	51,200	1	22.5	76,800	1	30.0	102,400

## OUTDOOR SOUND DATA

Unit Model No.	Octave Band Sound Power Levels dBA, re 10 <sup>-12</sup> Watts - Center Frequency - Hz							<sup>1</sup> Sound Rating Number dBA
	125	250	500	1000	2000	4000	8000	
ZHA036	66	70	75	73	71	67	60	79
ZHA048	66	70	75	73	71	67	60	79
ZHA060	71	74	80	76	73	69	64	83
ZHB036	66	70	75	73	71	67	60	79
ZHB048	62	69	73	72	69	65	57	78
ZHB060	70	72	78	75	72	70	66	82
ZHB072	70	77	81	80	76	73	69	86

<sup>1</sup> Sound Rating Number according to AHRI Standard 270-2008. Sound Rating Number is the overall A-Weighted Sound Power Level, (LWA), dB (100 Hz to 10,000 Hz).

## UNIT CLEARANCES

### UNIT WITH DOWNFLOW ECONOMIZER

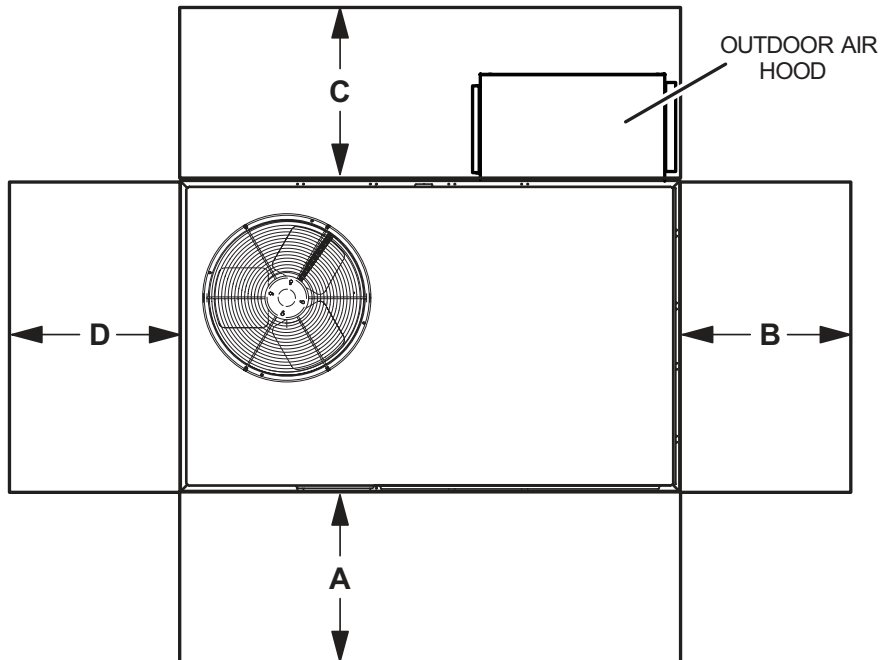

### UNIT WITH HORIZONTAL ECONOMIZER

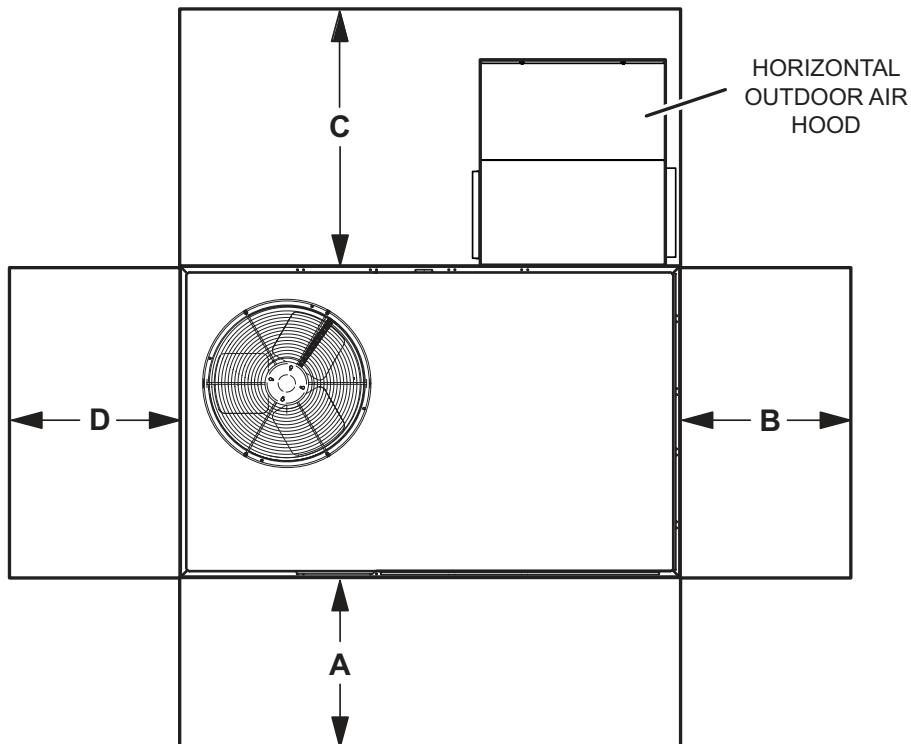

<sup>1</sup> Unit Clearance	A		B		C Downflow		C Horizontal		D		Top Clearance
	in.	mm	in.	mm	in.	mm	in.	mm	in.	mm	
<b>Service Clearance</b>	36	914	36	914	36	914	60	1524	36	914	<b>Unobstructed</b>
<b>Minimum Operation Clearance</b>	36	914	36	914	36	914	60	1524	36	914	

NOTE - Entire perimeter of unit base requires support when elevated above the mounting surface.

<sup>1</sup> **Service Clearance** - Required for removal of serviceable parts.

**Minimum Operation Clearance** - Required clearance for proper unit operation.

## WEIGHT DATA

Model Number	Net				Shipping			
	Base		Max.		Base		Max.	
	lbs.	kg	lbs.	kg	lbs.	kg	lbs.	kg
ZHA036S	530	240	581	264	535	243	586	266
ZHB036S	580	263	634	288	585	265	639	290
ZHA048S	539	244	590	268	544	247	595	270
ZHB048S	585	265	639	290	590	268	644	292
ZHA060S	585	265	639	290	590	268	644	292
ZHB060S	610	277	664	301	615	279	669	303
ZHB072S	683	310	702	318	715	324	735	333

Base Unit - The unit with NO OPTIONS.

Max. Unit - The unit with ALL OPTIONS Installed. (Economizer, etc.)

## OPTIONS / ACCESSORIES

		Shipping Weights	
		lbs.	kg
<b>ECONOMIZER</b>			
<b>Economizer</b>			
Economizer, Includes Outdoor Air Hood and Barometric Relief Dampers with Hood	Downflow	62	28
	Horizontal	92	42
<b>OUTDOOR AIR</b>			
<b>Outdoor Air Dampers</b>			
Motorized		39	18
Manual		29	13
<b>POWER EXHAUST</b>			
Standard Static	Downflow	54	24
	Horizontal	41	19
<b>ELECTRIC HEAT</b>			
	5 kW	25	11
	7.5 kW	26	12
	10 kW	27	12
	15 kW	27	12
	22.5 kW	29	13
	30 kW	30	14
<b>ROOF CURBS</b>			
<b>Hybrid Roof Curbs, Downflow</b>			
8 in. height	Z1CURB70A-1	63	29
14 in. height	Z1CURB71A-1	83	38
18 in. height	Z1CURB72A-1	93	42
24 in. height	Z1CURB73A-1	113	51
<b>CEILING DIFFUSERS</b>			
Step-Down	RTD9-65S	80	36
	RTD11-95S	118	54
Flush	FD9-65S	80	36
	FD11-95S	118	54

**DIMENSIONS - UNIT**

**ZHA**

Model No.	CORNER WEIGHTS												CENTER OF GRAVITY											
	AA		BB		CC		DD		EE		FF		Base		Max.		Base		Max.					
	Base	Max.	Base	Max.	Base	Max.	Base	Max.	Base	Max.	Base	Max.	Base	Max.	Base	Max.	Base	Max.	Base	Max.				
	lbs.	kg	lbs.	kg	lbs.	kg	lbs.	kg	lbs.	kg	lbs.	kg	lbs.	kg	in.	mm	in.	mm	in.	mm	in.	mm		
<b>036</b>	136	62	152	69	126	57	157	71	129	58	138	62	139	63	134	61	39.5	1003	37.5	953	23.25	591	25	635
<b>048</b>	139	63	155	70	128	58	159	72	131	59	140	63	142	64	136	62	39.5	1003	37.5	953	23.25	591	25	635
<b>060</b>	172	78	190	86	139	63	171	77	123	56	132	60	151	69	147	67	42	1067	40	1016	25	635	26.5	673

Base Unit - The unit with NO OPTIONS.

Max. Unit - The unit with ALL OPTIONS Installed. (Economizer, largest blower motor, etc.).

**BOTTOM POWER ENTRY**

Holes required for Optional Bottom Power Entry Kit

	Threaded Conduit Fittings (Provided in Kit)	Wire Use	Hole Diameter Required in Unit Base (Max.)
<b>A</b>	1/2	ACC	7/8 (23)
<b>B</b>	1/2	24V	7/8 (23)
<b>C</b>	3/4	POWER	1-1/8 (29)

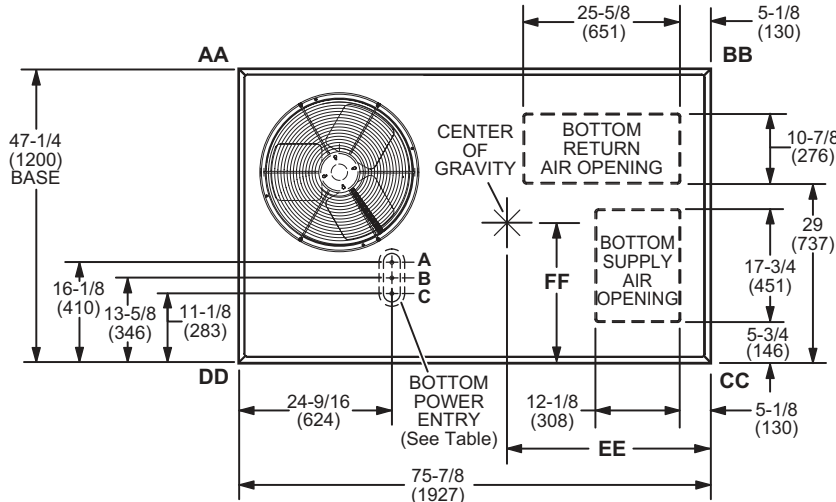

**TOP VIEW (Base)**

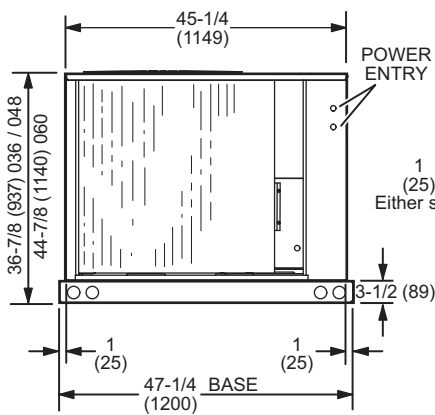

**END VIEW**

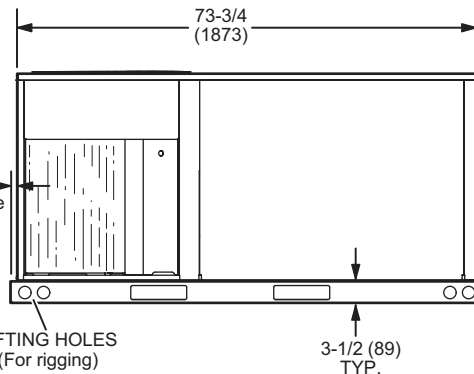

**FRONT VIEW**

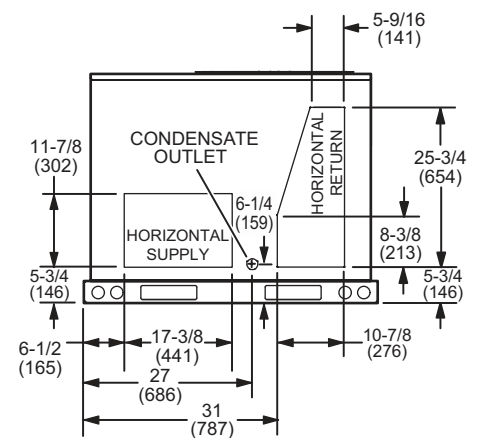

**END VIEW**

# DIMENSIONS - UNIT

ZHB

Model No.	CORNER WEIGHTS																CENTER OF GRAVITY							
	AA		BB				CC				DD				EE				FF					
	Base	Max.	Base	Max.	Base	Max.	Base	Max.	Base	Max.	Base	Max.	Base	Max.	Base	Max.	Base	Max.						
	lbs.	kg	lbs.	kg	lbs.	kg	lbs.	kg	lbs.	kg	lbs.	kg	lbs.	kg	in.	mm	in.	mm	in.	mm	in.	mm		
036	158	72	173	78	133	60	145	66	124	56	135	61	147	67	160	73	41.25	1048	39.25	997	24.5	622	25.75	654
048	168	76	183	83	136	62	148	67	120	54	130	59	148	67	161	73	42	1067	40	1016	25	635	26.5	673
060	163	74	177	80	142	64	155	70	142	64	155	70	163	74	177	80	40.5	1029	38.5	978	23.5	597	25	635
072	149	68	143	65	200	91	200	91	191	87	209	95	143	65	150	68	42	1067	41	1041	24	610	23	584

Base Unit - The unit with NO OPTIONS.

Max. Unit - The unit with ALL OPTIONS Installed. (Economizer, largest blower motor, etc.).

## BOTTOM POWER ENTRY

Holes required for Optional Bottom Power Entry Kit

	Threaded Conduit Fittings (Provided in Kit)	Wire Use	Hole Diameter Required in Unit Base (Max.)
E	1/2	ACC	7/8 (23)
F	1/2	24V	7/8 (23)
G	3/4	POWER	1-1/8 (29)

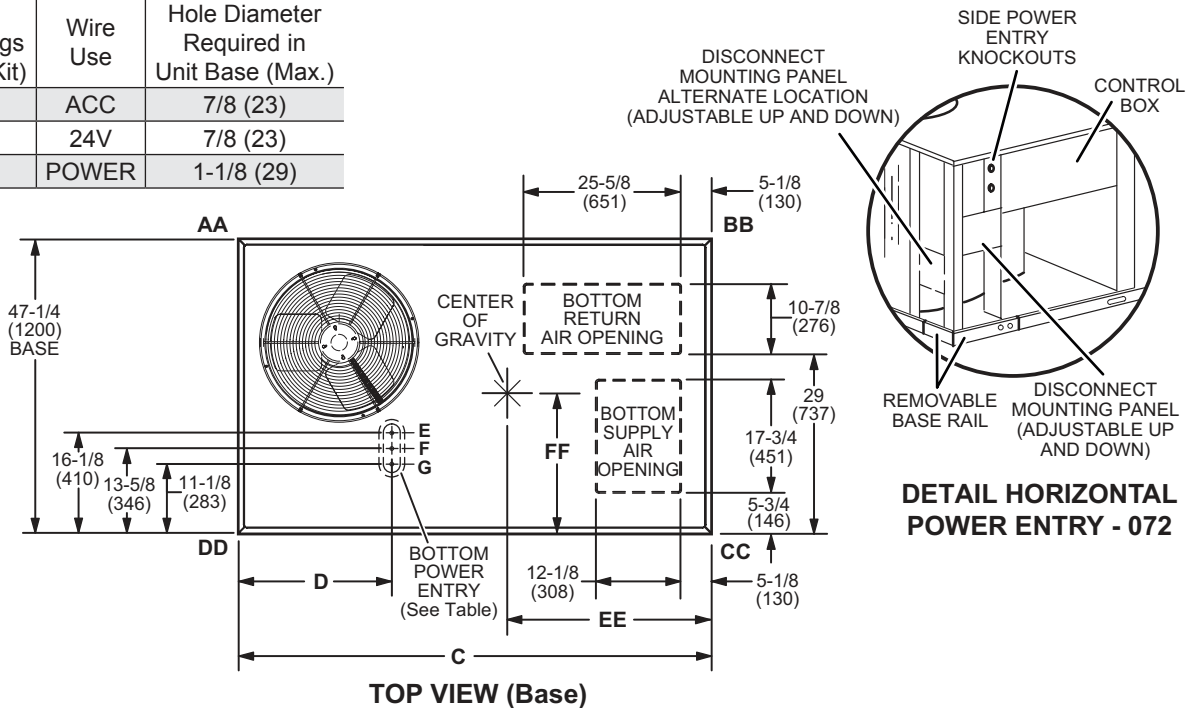

DETAIL HORIZONTAL POWER ENTRY - 072

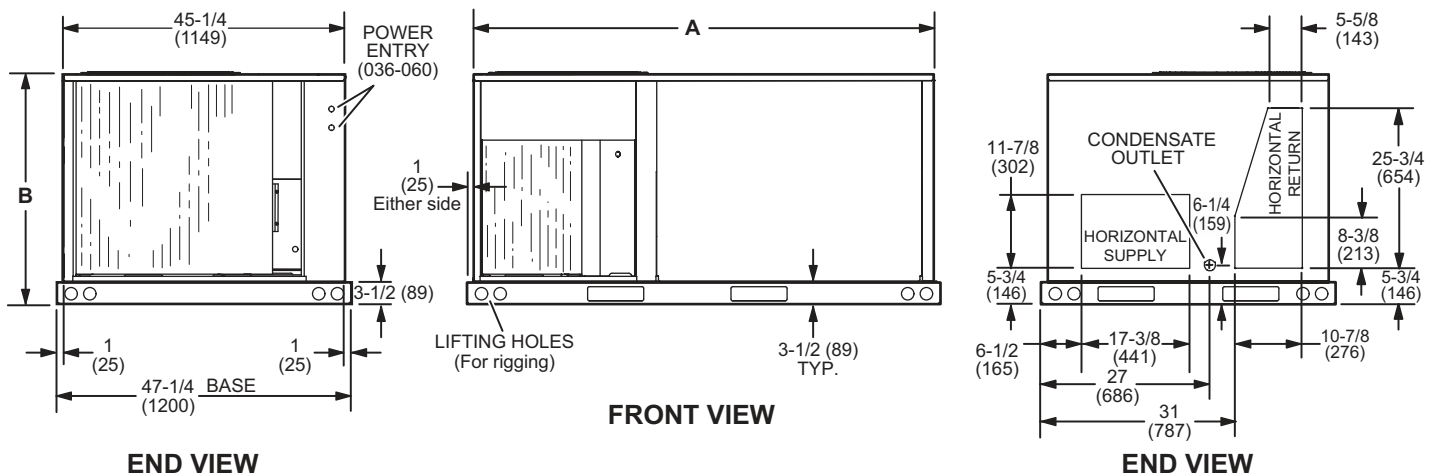

Model Number	A		B		C	
	in.	mm	in.	mm	in.	mm
ZHB036, 048	73-3/4	1873	75-7/8	1927	24-5/8	625
ZHB060	73-3/4	1873	75-7/8	1927	24-5/8	625
ZHB072	83-1/4	2115	85-1/4	2165	34	864

# DIMENSIONS - ACCESSORIES

## OUTDOOR AIR HOOD DETAIL FOR OPTIONAL ECONOMIZER (Downflow Applications)

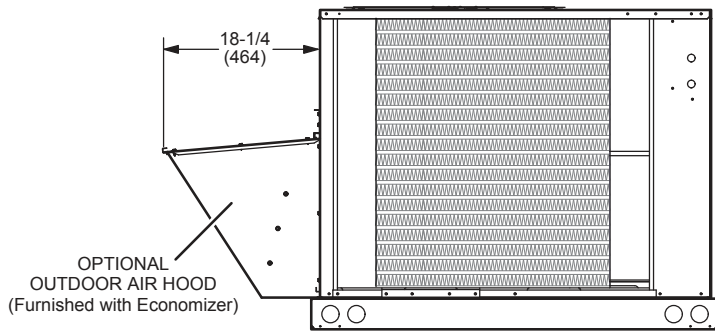

**SIDE VIEW**

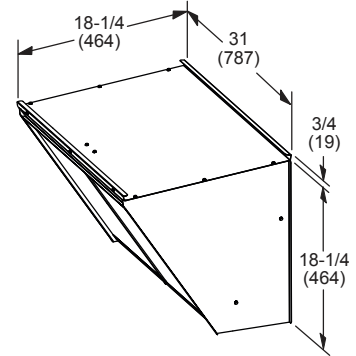

## OUTDOOR AIR DAMPER HOOD DETAIL (Downflow or Horizontal Applications)

### MANUAL OUTDOOR AIR DAMPER HOOD

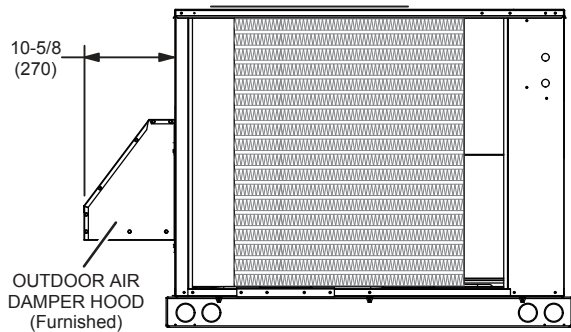

**END VIEW**

### MOTORIZED OUTDOOR AIR DAMPER HOOD

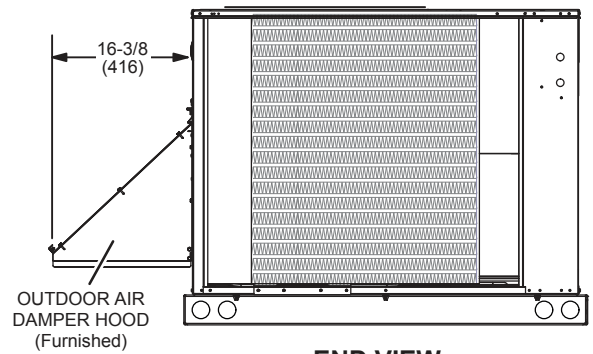

**END VIEW**

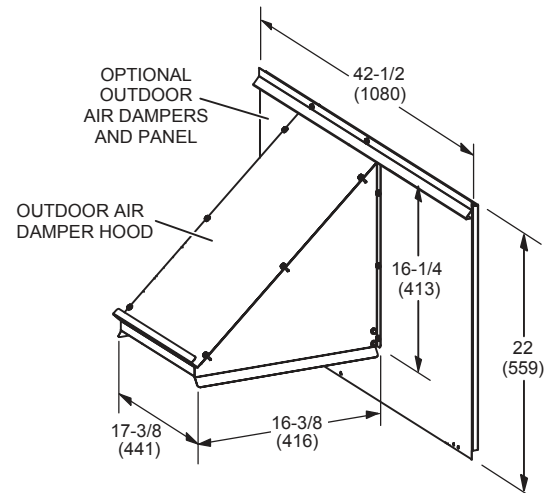
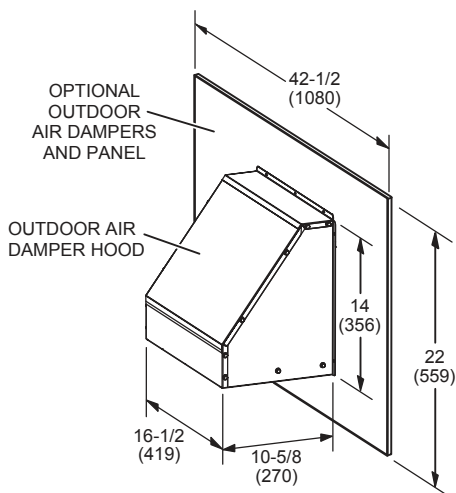

**OUTDOOR AIR HOOD DETAIL WITH OPTIONAL ECONOMIZER AND BAROMETRIC RELIEF DAMPERS  
(Horizontal Applications)**

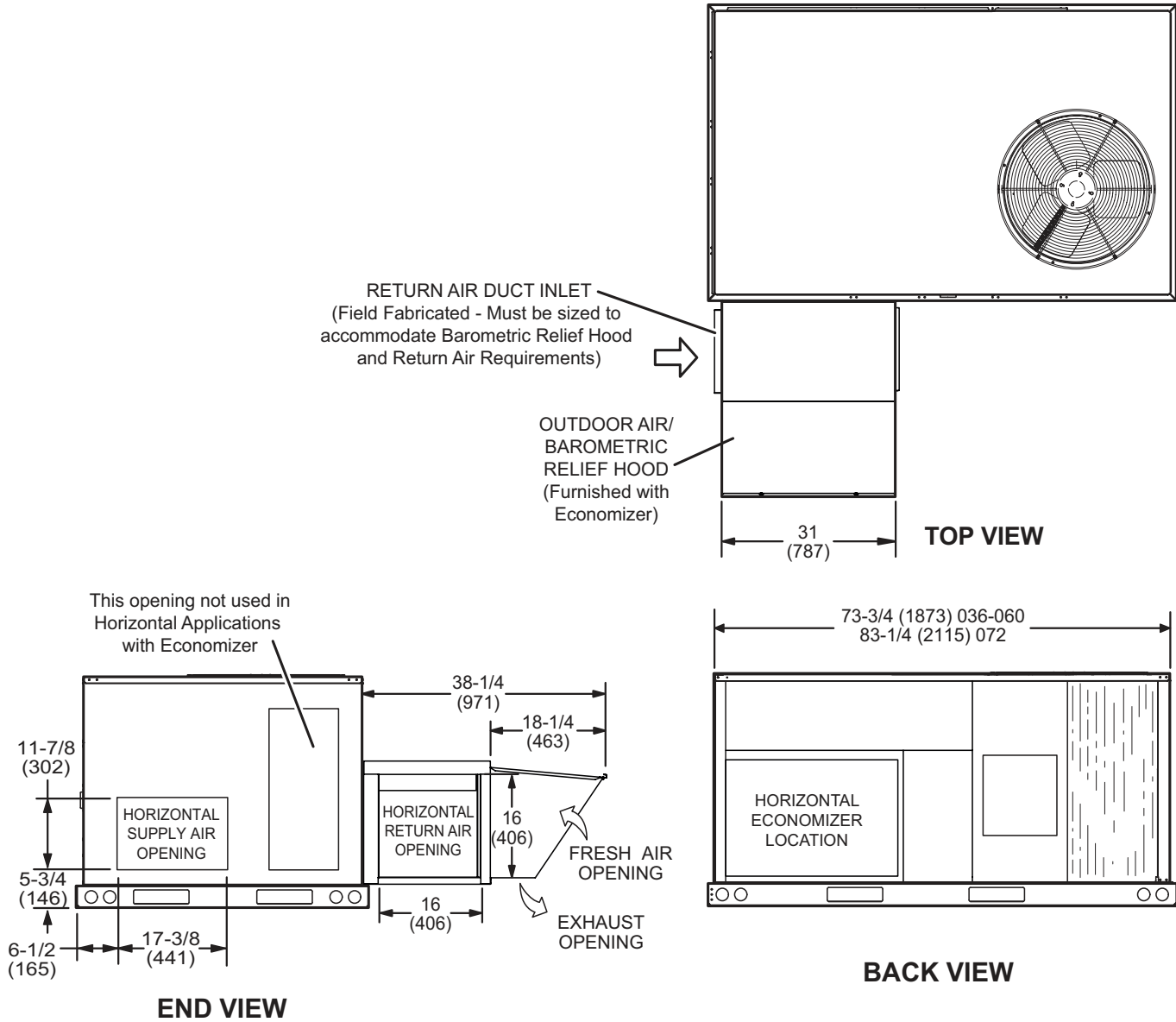

Note - Return Air Duct and Transition must be supported.

# DIMENSIONS - ACCESSORIES

## HYBRID ROOF CURBS - DOUBLE DUCT OPENING

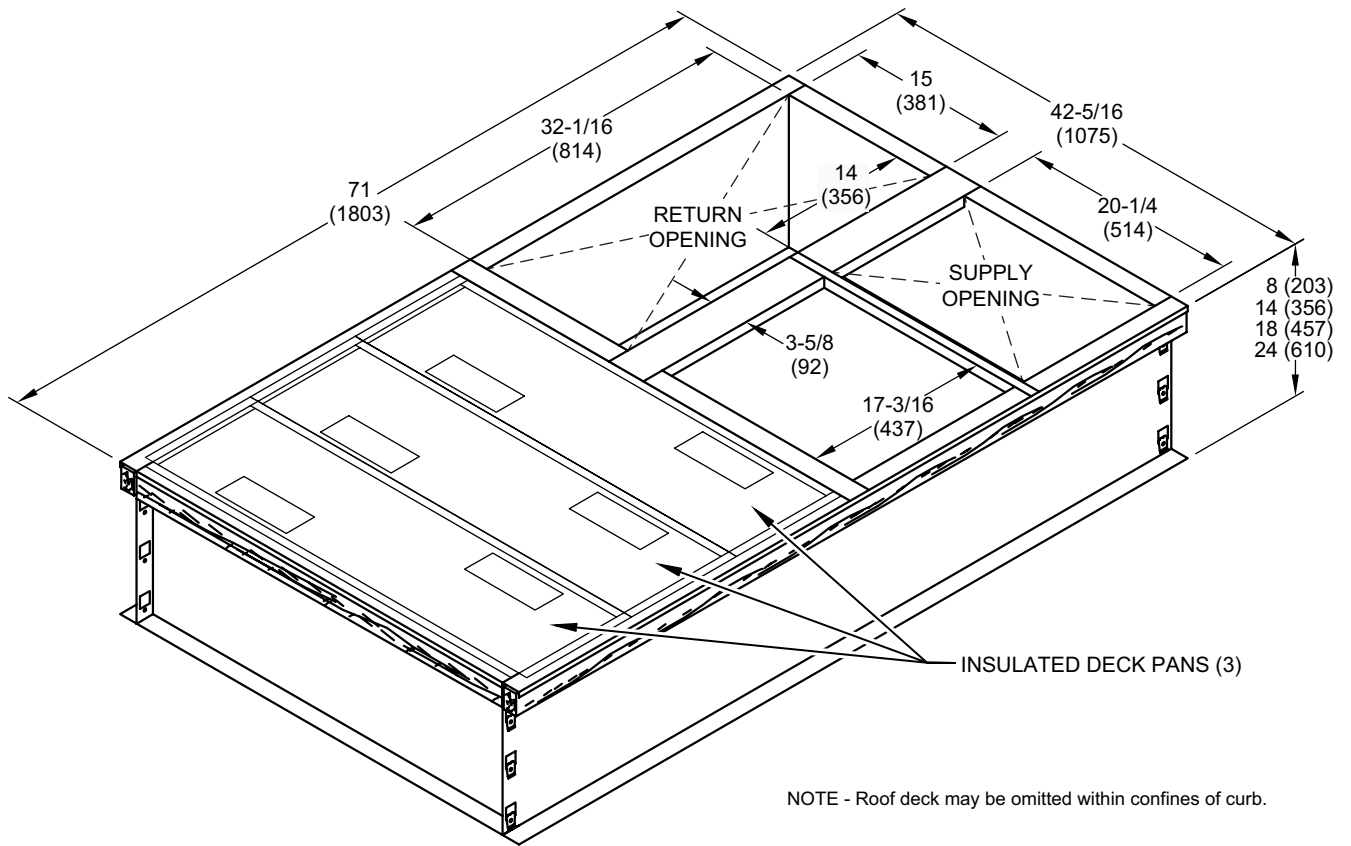

### TYPICAL FLASHING DETAIL FOR ROOF CURB

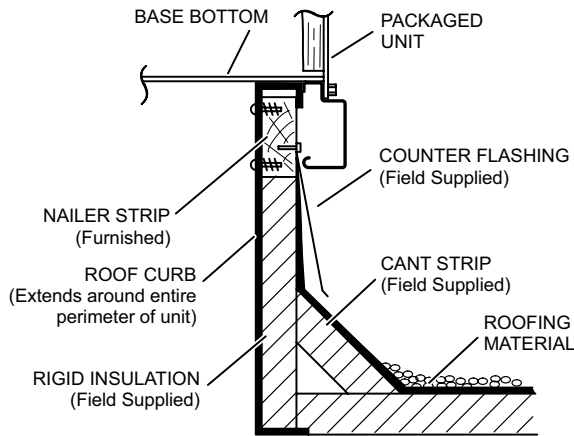

### DETAIL ROOF CURB

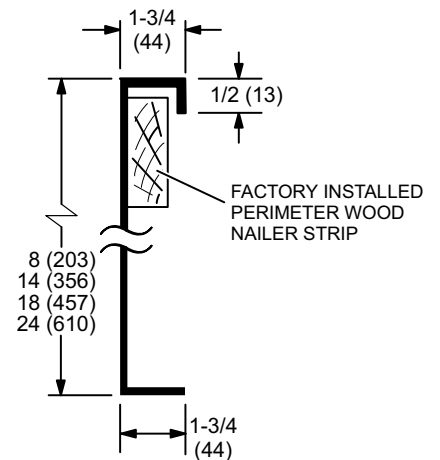

## DIMENSIONS - ACCESSORIES

### COMBINATION CEILING SUPPLY AND RETURN DIFFUSERS

#### STEP-DOWN CEILING DIFFUSER

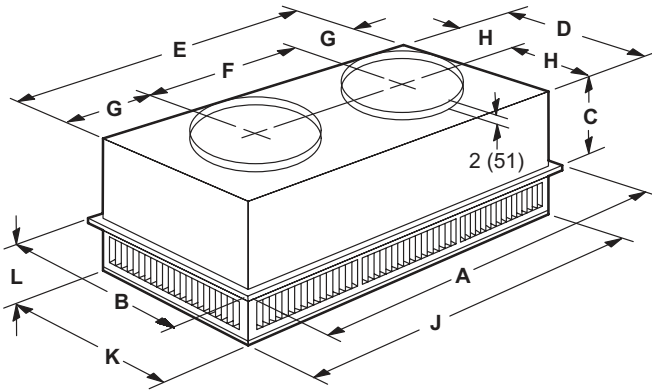

#### FLUSH CEILING DIFFUSER

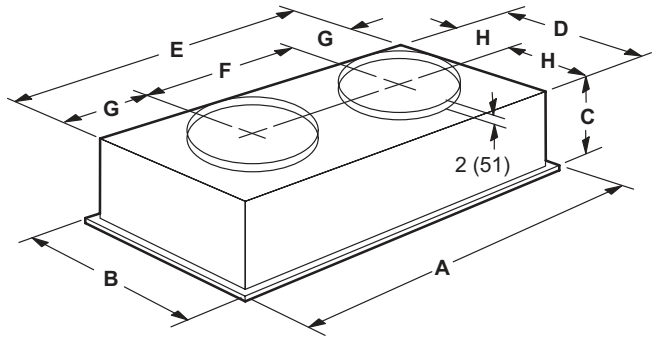

Model Number		RTD9-65S	RTD11-95S
A	in.	47-5/8	47-5/8
	mm	1159	1159
B	in.	23-5/8	29-5/8
	mm	600	752
C	in.	11-3/8	14-3/8
	mm	289	365
D	in.	21-1/2	27-1/2
	mm	546	699
E	in.	45-1/2	45-1/2
	mm	1156	1158
F	in.	22-1/2	22-1/2
	mm	572	572
G	in.	11-1/2	11-1/2
	mm	292	292
H	in.	10-3/4	13-3/4
	mm	273	349
J	in.	45-1/2	45-1/2
	mm	1156	1156
K	in.	21-1/2	27-1/2
	mm	546	699
L	in.	7-1/8	8-1/8
	mm	181	206
Duct Size	in.	18 round	20 round
	mm	457 round	508 round

Model Number		FD9-65S	FD11-95S
A	in.	47-5/8	47-5/8
	mm	1159	1159
B	in.	23-5/8	29-5/8
	mm	600	752
C	in.	13-1/2	16-5/8
	mm	343	422
D	in.	21	27
	mm	533	686
E	in.	45	45
	mm	1143	1143
F	in.	22-1/2	22-1/2
	mm	572	572
G	in.	11-1/4	11-1/4
	mm	286	286
H	in.	10-1/2	13-1/2
	mm	267	343
Duct Size	in.	18 round	20 round
	mm	457 round	508 round



## REVISIONS

Section	Description
Optional Conventional Temperature Control Systems	New model and catalog numbers for CS7500 thermostat.



Visit us at [www.lennox.com](http://www.lennox.com)

For the latest technical information, [www.lennoxcommercial.com](http://www.lennoxcommercial.com)

Contact us at 1-800-4-LENNOX

NOTE - Due to Lennox' ongoing commitment to quality, Specifications, Ratings and Dimensions subject to change without notice and without incurring liability. Improper installation, adjustment, alteration, service or maintenance can cause property damage or personal injury. Installation and service must be performed by a qualified installer and servicing agency.

©2019 Lennox Industries, Inc.