

LCM

MODEL L™ ROOFTOP UNITS

Ultra-High Efficiency | Lennox® CORE Controller | Environ™ Coil | **R-454B** | 60Hz



COMMERCIAL
PRODUCT SPECIFICATIONS (EHB)

13 to 25 Tons

Net Cooling Capacity – 150,000 to 270,000 Btuh
Optional Electric Heat - 15 to 90 kW

MODEL / L



SMARTWIRE™ SYSTEM



MODEL NUMBER IDENTIFICATION

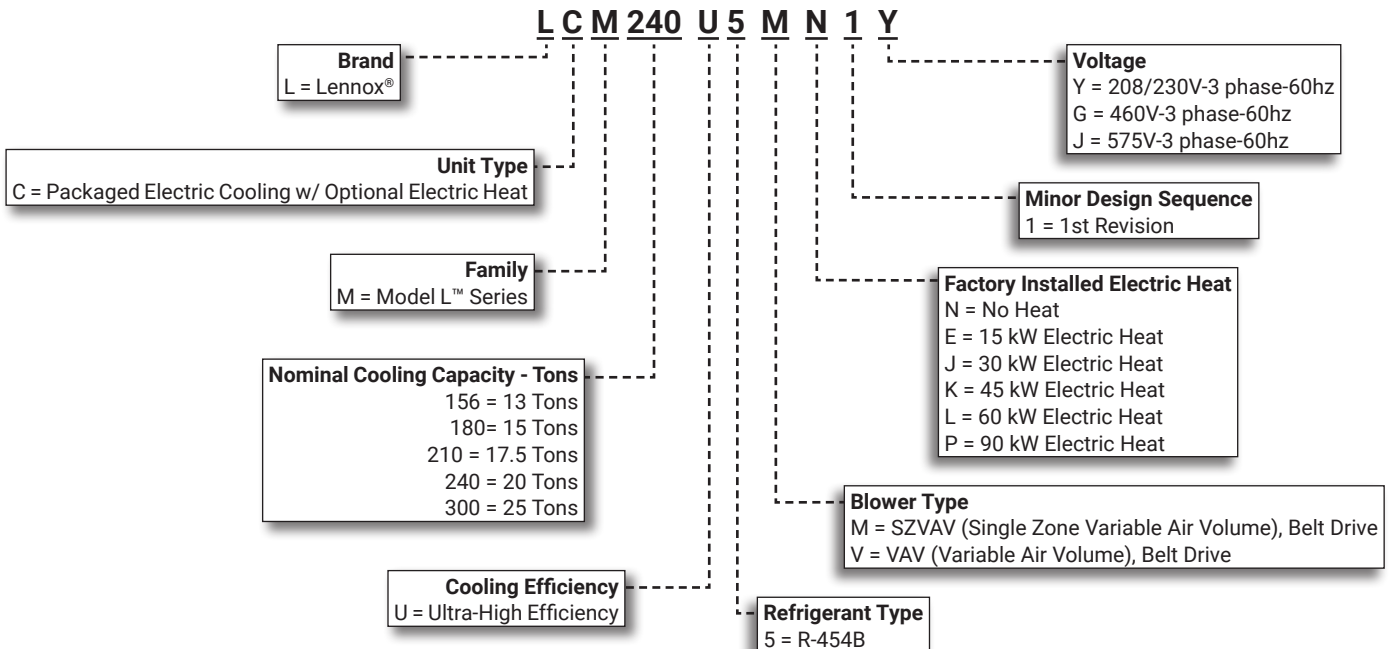

FEATURE HIGHLIGHTS

The Model L™ packaged rooftop line is engineered with advanced variable speed technology to offer some of the highest energy efficiencies in the industry while delivering superior temperature and humidity control in a wide variety of commercial applications.

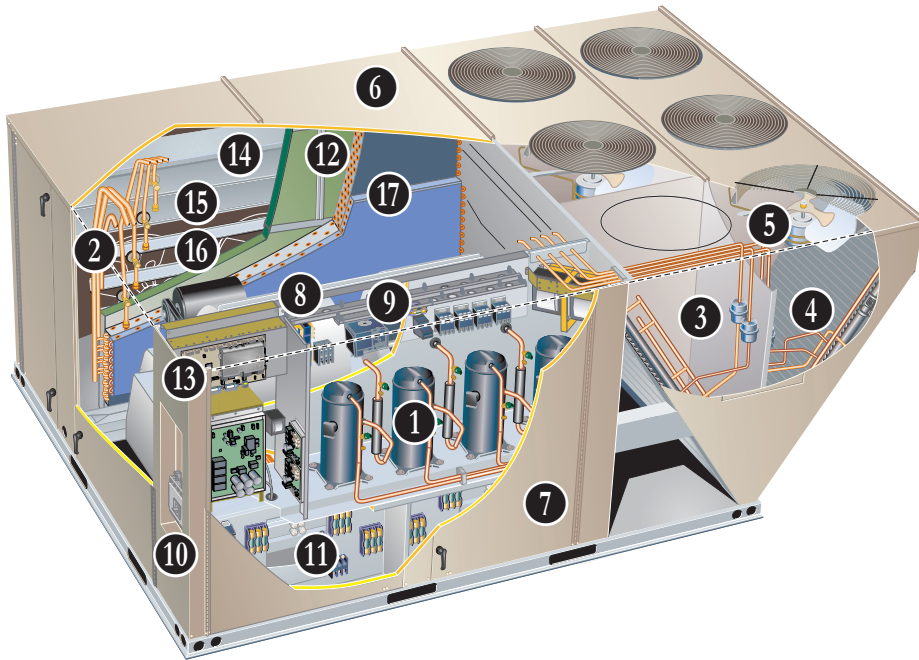

1. Variable Capacity Scroll Compressor (1) and Fixed Capacity Scroll Compressors (2 or 3)
2. Thermal Expansion Valves
3. Filter/Driers
4. Environ™ Coil System
5. Variable-Speed ECM Outdoor Coil Fan Motors (4) 156-180 and (6) 210-300
6. Heavy-Gauge Steel Cabinet
7. Hinged Access Panels
8. Supply Air Blower
9. Variable-Frequency Drive (VFD)
10. Disconnect Switch (option)
11. Electric Heat (option)
12. Air Filters
13. Lennox® CORE Control System
14. Economizer (option)
15. Downflow Barometric Relief Dampers (option)
16. Power Exhaust Fans (option)
17. Humiditrol®+ Dehumidification System (option)

CONTENTS

Approvals And Warranty	3
Blower Data	35
Control System	9
Cooling Ratings	27
Dimensions	47
- Accessories	49
- LCM156 LCM180	47
- LCM210 LCM240 LCM300	48
Electrical Accessories - Disconnects	43
Electrical/Electric Heat Data	38
- 13 Ton	38
- 15 Ton	39
- 17.5 Ton	40
- 20 Ton	41
- 25 Ton	42
Electric Heat Capacities	45
Features And Benefits	3
Humiditrol®+ Dehumidification System Option.	13
Humiditrol™+ Dehumidification System Ratings	32
Model Number Identification.	1
Optional Conventional Temperature Control Systems	15
Options / Accessories	20
Outdoor Sound Data	45
Sequence Of Operation.	17
Specifications	24
- 13 Ton	24
- 15 Ton 17.5 Ton	25
- 20 Ton 25 Ton.	26
Unit Clearances	45
Weight Data	46
- Unit	46

APPROVALS AND WARRANTY

APPROVALS

- AHRI Standard 340/360 certified
- ETL and CSA listed
- Unit and components ETL, NEC, and CEC bonded for grounding to meet safety standards for servicing
- All models are ASHRAE 90.1 compliant
- All models meet DOE 2023 energy efficiency standards and UL 60335-2-40 Refrigerant Detector Requirements
- All models meet California Code of Regulations, Title 24 requirements for staged airflow
- All models have HCAI (formerly OSHPD) OSP and Special Seismic Certification ([Number: OSP-0596](#)), and meet 2021 International Building Code (IBC), 2022 California Building Code (CBC) ASCE 7, and ICC-ES AC156
- ENERGY STAR® certified
- ISO 9001 Registered Manufacturing Quality System

WARRANTY

- Compressors - Limited five years
- Environ™ Coil System - Limited three years
- Lennox® CORE Unit Controller - Limited three years
- Variable-Frequency Drive (VFD) - Limited five years
- High Performance Economizers (optional) - Limited five years
- All other covered components - Limited one year

FEATURES AND BENEFITS

COOLING SYSTEM

- Designed to maximize sensible and latent cooling performance at design conditions
- System can operate from 0°F to 125°F without any additional controls

R-454B Refrigerant

- Low GWP (Global Warming Potential)
- Zero ODP (Ozone Depletion Potential)
- Low Toxicity/Lower Flammability - A2L
- Unit is factory pre-charged

1 Multiple Compressors

Cooling system consists of one variable capacity scroll compressor and multiple fixed capacity scroll compressors (two for 156-180 models, three for 210-300 models)

Variable Capacity Scroll Compressor

- High performance, reliability and quiet operation
- Operates on a variable-frequency determined to vary capacity based on the cooling load required

Fixed Capacity Scroll Compressors

- High performance, reliability and quiet operation
- Resiliently mounted on rubber grommets for quiet operation

DC Inverter Control (for Variable Capacity Compressor)

- Converts AC line voltage into filtered variable DC voltage
- Provides continuous compressor operation, while adjusting the capacity according to discharge air temperature
- Adjusts compressor output in increments as small as 1%

- Prevents frequent changes in capacity and ensures efficient, economical operation
- Power Factor Correction (PFC) circuit monitors the DC bus for high, low and abnormal voltage conditions to protect the compressor
- Two LEDs (red and green) indicate inverter operating status and aid in troubleshooting
- Noise filter reduces unwanted electromagnetic interference (EMI)
- Inverter reactor adds inductance to the line between the inverter and the compressor to limit current rise and protect the compressor

Compressor Crankcase Heaters

- Protects against refrigerant migration that can occur during low ambient operation or during extended off cycles

2 Thermal Expansion Valves

- Ensures optimal performance throughout the application range
- Removable element head

3 Filter/Driers

- High capacity filter/drier protects the system from dirt and moisture

High Pressure Switches

- Protects the compressors from overload conditions such as dirty condenser coils, blocked refrigerant flow, or loss of outdoor fan operation

Low Pressure Switches

- Protects the compressors from low pressure conditions such as low refrigerant charge or low/no airflow

FEATURES AND BENEFITS

COOLING SYSTEM (continued)

Diagnostic and Sensor System

- Multiple thermistors continuously monitor the refrigeration system, providing optimum performance and complete circuit protection at all operating conditions

Indoor Coil Freeze Protection

- Protects the evaporator coil from damaging ice build-up due to conditions such as low/no airflow, or low refrigerant charge

4 Condenser Coil - Environ™ Coil System

- Lightweight, all aluminum brazed fin construction
- Constructed of three components
 - A flat extrusion tube
 - Fins in-between the flat extrusion tube
 - Two refrigerant manifolds

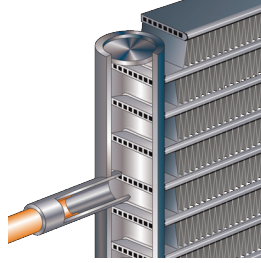

Environ™ Coil System Features:

- Improved heat transfer performance due to high primary surface area (flat tubes) versus secondary surface (fins)
- Smaller internal volume (reduced refrigerant charge)
- High durability
- All aluminum construction
- Fewer brazed joints
- Compact design
- Reduced unit weight
- Easy maintenance/cleaning
- Mounting brackets with rubber inserts secure coil to unit providing vibration dampening and corrosion protection

Evaporator Coil

- Copper tube construction
- Enhanced rippled-edge aluminum fins
- Flared shoulder tubing connections
- Silver soldered construction for improved heat transfer
- Factory leak tested
- Cross row circuiting with rifled tubing optimizes both sensible and latent cooling capacity

Anti-Microbial Condensate Drain Pan

- Plastic pan, sloped to meet drainage requirements per ASHRAE 62.1
- Anti-Microbial additive resists growth of mold and mildew on drain pan, which improves indoor air quality and reduces drain line blockage
- Side or bottom drain connections

5 Variable-Speed ECM Outdoor Coil Fan Motors

- Fan speed is directly controlled by the Lennox® CORE Unit Controller
- Thermal overload protected
- Totally enclosed
- Permanently lubricated ball bearings
- Shaft up
- Wire basket mount

Outdoor Coil Fans

- PVC coated fan guards furnished

Required Selections

Cooling Capacity

- Specify nominal cooling capacity

Options/Accessories

Factory or Field Installed

Drain Pan Overflow Switch

- Monitors condensate level in drain pan
- Shuts down unit if drain becomes clogged

Field Installed

Condensate Drain Trap

- Available in copper or PVC

LOW GWP REFRIGERANT DETECTION SYSTEM (RDS)

- Complies with UL 60335-2-40 approved standard
- Required for all systems using R-454B refrigerant
- Factory installed on all units
- Consists of a refrigerant detection sensor(s) and a mitigation control
- Ensures safe operation for systems equipped with R-454B refrigerant
- Sensor(s) monitors indoor coil area for R-454B refrigerant
- If R-454B refrigerant is detected the refrigerant detection system will prevent compressor and heating operation until R-454B refrigerant is no longer detected
- Refrigeration detection system energizes blower if any R-454B refrigerant is detected to mitigate any concentrations of refrigerant from the unit and the system

FEATURES AND BENEFITS

CABINET

6 Construction

- Heavy-gauge steel panels
- Full perimeter heavy-gauge galvanized steel base rail
- Base rails have rigging holes
- Three sides of the base rail have forklift slots
- Raised edges around duct and power entry openings in the bottom of the unit for water protection

Airflow Choice

- Units are shipped in downflow (vertical) configuration

NOTE - Units can be field converted to horizontal air flow with optional Horizontal Return Air Panel Kit and Horizontal Roof Curb.

Power Entry

- Electrical lines can be routed through the unit base or through horizontal access knock-outs

Exterior Panels

- Constructed of heavy-gauge, galvanized steel
- Textured pre-paint with polyurethane finish
- Cyclic salt fog and UV exposure up to 1680 hours per ASTM D5894

Insulation

- Fully insulated with non-hygroscopic fiberglass insulation (conditioned areas)
- Unit base is fully insulated
- Base insulation serves as an air seal to the roof curb, eliminating the need to add a seal during installation

7 Hinged Access Panels

- Filter section
- Blower section
- Heating section
- Compressor/controls section
- Panel seals and quarter-turn latching handles provide a tight air and water seal

Required Selections

Airflow Configuration

- Specify downflow or horizontal

CABINET (continued)

Options/Accessories

Factory Installed

Corrosion Protection

- Completely flexible immersed coating
- Electrodeposited dry film process (AST ElectroFin E-Coat)
- ASTM B117 / DIN 53167 Salt Spray - 15,000+ hours
- ASTM G85 Annex A3 SWAAT Modified Salt Spray - 3000 hours
- VA Master Construction Specification Division 23 for High Humidity Installations
- CID AA-52474A (GSA)
- Indoor Corrosion Protection:

- Coated coil
- Coated reheat coil (Humiditrol®+)
- Painted blower housing
- Painted indoor base
- Outdoor Corrosion Protection:
 - Coated coil
 - Painted outdoor base

Factory or Field Installed

Combination Coil/Hail Guards

- Heavy gauge steel frame
- Painted to match cabinet
- Expanded metal mesh protects outdoor coil

Field Installed

Horizontal Return Air Panel Kit

- Required for horizontal applications with Horizontal Roof Curb
- Contains panel with return air opening for field replacement of existing unit panel and panel to cover bottom return air opening in unit
- See dimension drawings

Burglar Bars

- Heavy gauge galvanized frame
- Fully welded
- 3/4 in. bar meets ASTM specification
- Frame meets ASTM A446, A525, A526 and A527 specification
- Burglar bars designed to fit ductwork

FEATURES AND BENEFITS

BLOWER

A wide selection of supply air blower options are available to meet a variety of airflow requirements

Motor

- Overload protected, equipped with ball bearings
- Belt drive motors are offered on all models and are available in several different sizes to maximize air performance

Motor Efficiency

- All blower motors 5 HP and above meet minimum energy efficiency standards in accordance with the Energy Independence and Security Act (EISA) of 2007

8 Supply Air Blower

- Forward curved blades
- Double inlet
- Blower wheel is statically and dynamically balanced
- Ball bearings
- Adjustable pulley (allows speed change)
- Blower assembly slides out of unit for servicing
- Grease fittings furnished

Blower Proving Switch

- Monitors blower operation, shuts down unit if blower fails

Supply Static Pressure Transducer (VAV Models Only)

- Sends information to the Lennox® CORE Unit Controller to control VFD blower speed
- Shipped with the unit for remote field installation in the supply duct

Required Selections

Select SZVAV (Single Zone Variable Air Volume) or Variable Air Volume (VAV) Models

- SZVAV (Single Zone Variable Air Volume) modulates the amount of airflow according to cooling demand, heating demand, ventilation demand or smoke alarm
- Variable Air Volume (VAV) modulates the air volume to maintain a constant duct static pressure

- **9** Utilizes a Variable-Frequency Drive (VFD) to modulate the supply blower airflow
 - VFD alters the frequency and voltage of the power supply to the blower to control blower speed
 - The amount of airflow for each stage can be set according to a parameter in the Lennox® CORE unit controller
 - Unit is shipped from the factory with preset airflows
 - SZVAV can be ordered with or without an Electronic Bypass Control
 - If equipped with the bypass control the SZVAV features manual (default) or automatic electronic bypass control of the VFD
 - In case of a VFD malfunction, a VFD alarm is generated by the Lennox® CORE unit controller

- VFD can be manually bypassed to continue unit operation at full blower speed or the unit controller can be set to automatically switch to full blower speed if a VFD alarm is generated
- VFD has an operational range of -40 to 125°F outdoor air ambient temperature
- Lower operating costs are obtained when the blower is operated on lower speeds

NOTE - Variable-Frequency Drive (VFD) is designed to operate on balanced, three-phase power. Operating units on unbalanced three-phase power will reduce the reliability of all electrical components in the unit. Unbalanced power is a result of the power delivery system supplied by the local utility company. Factory-installed inverters are sized to drive blower motors with an equivalent current rating using balanced three-phase power. If unbalanced three-phase power is supplied; the installer must replace the existing factory-installed inverter with an inverter that has a higher current rating to allow for the imbalance. Refer to the installation instructions for additional information and replacement information

Ordering Information

- Specify motor horsepower and drive kit number when base unit is ordered

Options/Accessories

Field Installed

Blower Belt Auto-Tensioner

- Provides proper tension to belt drive blower belt without the need for regular adjustments
- Maintains airflow and proper performance

FEATURES AND BENEFITS

ELECTRICAL

NOTE - All units include terminal block and fuse block in power entry junction box for single power entry application.

SmartWire™ System

- Keyed and color-coded wiring connectors prevent miswiring
- Wire coloring scheme is standardized across all models
- Each connection is intuitively labeled to make troubleshooting and servicing quick and easy

Electrical Plugs

- Positive connection electrical plugs connect common accessories or maintenance parts for easy removal or installation

Phase/Voltage Detection

- Monitors power supply to ensure phase is correct at unit start-up
- If phase is incorrect, the unit will not start and an alarm code is reported to the unit controller
- Protects unit from being started with incorrect phasing which could lead to issues such as compressors running backwards
- Voltage detection monitors power supply voltage to ensure proper voltage
- If voltage is not correct (over/under voltage conditions) the unit will not start and an alarm code is reported to the unit controller

Required Selections

Voltage Choice

- Specify when ordering base unit

Options/Accessories

Factory Installed

Circuit Breakers

- HACR type
- Overload and short circuit protection
- Factory wired and mounted in the power entry panel
- Current sensitive and temperature activated
- Manual reset

Short-Circuit Current Rating (SCCR)

- Higher short-circuit protection up to 100kA

NOTE - Disconnect Switch not available with higher SCCR option. Short-Circuit Current Rating option not available on field installed electric heat or 90kW electric heat (208/240V) models.

Factory or Field Installed

10 Disconnect Switch

- Accessible outside of unit
- Spring loaded weatherproof cover furnished

11 Electric Heat

- Helix wound nichrome elements
- Individual element limit controls
- Wiring harness
- Unit fuse block
- See Options/Accessories tables for ordering information

GFI Service Outlets (2)

- 115V ground fault circuit interrupter (GFCI) type
- Available non-powered, field-wired or factory-wired and powered

Field Installed

GFI Weatherproof Cover

- Single-gang cover
- Heavy-duty UV-resistant polycarbonate case construction
- Hinged base cover with gasket

FEATURES AND BENEFITS

INDOOR AIR QUALITY

12

Air Filters

- Disposable 2 inch MERV 4 filters furnished as standard

Options/Accessories

Factory or Field Installed

Healthy Climate® High Efficiency Air Filters

- Disposable MERV 8, MERV 13 or MERV 16 (Minimum Efficiency Reporting Value based on ASHRAE 52.2) efficiency 2 inch pleated filters

Field Installed

Healthy Climate® UVC Germicidal Light Kit

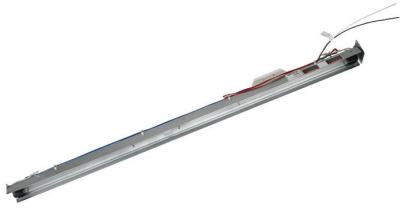

- Germicidal lamps emit ultra-violet (UV-C) energy, which has been proven to be effective in reducing microbes such as viruses, bacteria, yeasts, and molds
- This process either destroys the organism or controls its ability to reproduce
- UV-C energy greatly reduces the growth and proliferation of mold and other bioaerosols (bacteria and viruses) on illuminated surfaces (particularly coil and drain pan)
- Installed in the blower/evaporator coil section
- Safety interlock switch automatically shuts off power to the UVC light when panel is removed
- Interlock switch is factory installed or field installed in the blower/evaporator coil section panel
- All necessary hardware for installation is included
- Lamps operate on 110/230V, 1 phase power supply

NOTE - Step-down transformer may be ordered for field installed UVC lamps when used with 460V and 575V rooftop units. Step-down transformer is furnished with lamps when factory installed.

- Approved by ETL

Needlepoint Bipolar Ionization (NPBI) Kit

- NPBI technology integrates with system controls for effective air treatment
- Ionization has been shown to effectively reduce harmful pathogens, pollutants and odors
- Brush-type ionizer introduces a high concentration of both positive and negative ions into the airstream
- These bipolar ions are then dispersed into the occupied space through the duct system proactively reducing the airborne contaminants
- Ions travel within the building air stream and attach to particles, pathogens, and gas molecules, making them larger and easier to capture in the filtration system
- UL 2998 certified for zero ozone emission

Indoor Air Quality (CO₂) Sensors

- Monitors CO₂ levels, reports to the Lennox® CORE Unit Controller which adjusts Economizer dampers as needed

Replacement Filter Media Kit With Frame

- Replaces existing pleated filter media
- Includes washable metal mesh screen and metal frame with clip for holding replaceable non-pleated filter

CONTROL SYSTEM

LENNOX® CORE CONTROL SYSTEM

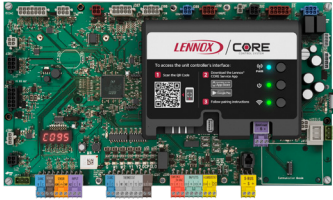

The Lennox® CORE Control System is designed to accelerate equipment install and service. Standard with all Model L™ rooftop units, control system integrates key technologies that lower installation costs, drive system efficiency, and protect your investments.

- 13** The Lennox® CORE Unit Controller is a microprocessor-based controller that provides flexible control of all unit functions.

CORE Mobile Service App

- Guided Setup with progress indicators, detailed help, and exportable summaries to manage simple, trouble-free setup, reducing commissioning times
- Enhanced Test Functionality provides real-time sensor readings, trending, and reports that enable easy troubleshooting
- Ability to set and configure parameters of the CORE Control System to manage sequence of operation
- Economizer test function ensures economizer is operating correctly



Additional Features:

- Built-In 7-Segment Display shows Unit Status and active alarms for easy troubleshooting
- Buttons for test and clearing delays
- SmartWire™ System with keyed and removable screw terminals ensure correct field wiring
- Built-in BACnet MS/TP and IP allow open integration to building management systems.
- Two-port Ethernet Switch enables daisy chaining for BACnet IP and automatic firmware updates

NOTE - Unit Internet Connection required.

- Profile setup copies key settings between units with the same configuration to reduce setup time
- USB port allows a technician to download and transfer unit information to help verify service was performed
- USB software updates on the Lennox® CORE Unit Controller enhance functionality without the need to change components
- Unit Controller Software

Configurable Built-In Functions

- Full modulation of variable speed compressor for discharge air temperature control in room sensor or thermostat mode
- Discharge Air Cooling Control
- Up to three distinct Cooling Airflows in Thermostat Mode

- Programmable independent heating, ventilation and cooling blower speeds
- Discharge Air Heating Control
- Economizer Control Options (See Economizer / Exhaust Air / Outdoor Air sections)
- Exhaust Fan Control Modes for fresh air damper position
- Configurable Morning Warm-up
- Night Setback Mode
- Fresh Air Tempering for Improved Ventilation
- Demand Control Ventilation
- Low Ambient Controls for operation down to 0°F
- Humiditrol®+ Operation
- Enhanced Dehumidification (Latent Demand Control without hot gas reheat)

Component Protection / Unit Safeguards:

- Compressor Time-Off Delay
- Adjustable Blower On/Off Delay
- Return Air Temperature Limit Control
- Safety Switch Input allows Controller to respond to a external safety switch trip
- Service Relay Output
- Thermostat Bounce Delay
- Smoke Alarm Mode has four choices (unit off, positive pressure, negative pressure, purge)
- "Strike Three" Protection
- Gas Valve Time Delay Between First and Second Stage
- Minimum Compressor Run Time

Control Methods / Interfaces:

- DDC and 24V Thermostat
- BACnet MS/TP and IP
- LONTalk (Factory and Field Option)
- Lennox S-BUS
- Compatibility with Lennox Wireless Room Sensors
- Zone Temperature Sensor Input
- Dehumidistat and Humidity Sensor Inputs
- Indoor Air Quality Inputs (2)
- Built-in Control Parameter Defaults
- Permanent Diagnostic Code Storage
- Field Adjustable Control Parameters (Over 200 settings)
- Multiple Configurable Digital Inputs
- LED Indicators
- PC Interface connects the Lennox® CORE Unit Controller to a PC with the Lennox Unit Controller Software

NOTE - Lennox® CORE Control System features vary with the type of rooftop unit in which the control is installed.

CONTROL SYSTEM

LENNOX® CORE CONTROL SYSTEM (continued)

Control Options

Factory or Field Installed

Dirty Filter Switch

- Senses static pressure increase and issues alarm if necessary

Fresh Air Tempering

- Used in applications with high outside air requirements
- Controller energizes the first stage heat as needed to maintain a minimum supply air temperature for comfort, regardless of the thermostat demand
- When ordered as a factory option, sensor ships with the unit for field installation

Smoke Detector

- Photoelectric type
- Installed in supply air section, return air section or both sections
- Available with power board and single sensor (supply or return) or power board and two sensors (supply and return)
- Power board located in unit control compartment

COMMERCIAL CONTROL SYSTEMS

Interoperability via BACnet® or LonTalk® Protocols

- Communication compatible with third-party automation systems that support the BACnet Application Specific Controller device profile, LonMark® Space Comfort Controller functional profile, or LonMark Discharge Air Controller functional profile

Field Installed

Thermostats and Room Sensors

- Control system and thermostat options, see page 15

OPTIONS / ACCESSORIES

ECONOMIZER

- Economizer operation is set and controlled by the Lennox® CORE unit controller
- Simple plug-in connections from Economizer to unit controller for easy installation
- All Model L™ rooftop units are equipped with factory installed CEC Title 24 approved sensors for outside, return and discharge air temperature monitoring

NOTE - Optional sensors may be used instead of unit sensors to determine whether outdoor air is suitable for free cooling. See Options/Accessories table.

Factory or Field Installed

14 High Performance Economizer

- Approved for California Title 24 building standards
- Low leakage dampers are Air Movement and Control Association International (AMCA) Class 1A Certified - Maximum 3 CFM per sq. ft. leakage at 1 in. w.g.
- ASHRAE 90.1 and IECC compliant
- Downflow or Horizontal with Outdoor Air Hood
- Outdoor Air Hood with mist elimination is included when Economizer is factory installed and is furnished with Economizer when ordered for field installation

NOTE - Downflow or horizontal economizer applications require optional Downflow or Horizontal Barometric Relief Dampers with Exhaust Hood.

- Linked damper action
- High torque 24-volt fully-modulating spring return damper motor
- Return air and outdoor air dampers
- Plug-in connections to unit

NOTE - High Performance Economizers are not approved for use with enthalpy controls in Title 24 applications.

NOTE - The Free Cooling setpoint for Title 24 applications must be set based on the Climate Zone where the system is installed. See Section 140.4 "Prescriptive Requirements for Space Conditioning Systems" of the California Energy Commission's 2022 Building Energy Efficiency Standards.

NOTE - Refer to Installation Instructions for complete setup information.

Differential Sensible Control

- Factory setting
- Uses outdoor air and return air sensors that are furnished with the unit
- The Lennox® CORE unit controller compares outdoor air temperature with return air
- When the outdoor air is below the configured setpoint and cooler than return air, the controller activates the Economizer

OPTIONS / ACCESSORIES

ECONOMIZER (continued)

Factory or Field Installed (continued)

NOTE - Differential Sensible Control can be configured in the field to provide Offset Differential Sensible Control or Single Sensible Control.

NOTE - In Offset Differential Sensible Control mode, the Economizer is enabled if the temperature differential (offset) between outdoor air and return air reaches the configured setpoint. In Single Sensible Control mode, the Economizer is enabled when outdoor air temperature falls below the configured setpoint.

Global Control

- The unit controller communicates with a DDC system with one global sensor (enthalpy or sensible)
- Determines whether outside air is suitable for free cooling on all units connected to the control system
- Sensor must be field provided

Single Enthalpy Temperature Control (Not for Title 24)

- Outdoor air enthalpy sensor enables Economizer if the outdoor enthalpy is less than the setpoint of the control

Differential Enthalpy Control (Not for Title 24)

- Order two Single Enthalpy Controls
- One is field installed in the return air section
- One is installed in the outdoor air section
- Allows the Economizer control to select between outdoor air or return air, whichever has lower enthalpy

Field Installed

Outdoor Air CFM Control

- Maintains constant outdoor air volume levels on the supply air fan and varying unit airflows
- Velocity sensor located in the rooftop unit outdoor air section, the Lennox® CORE unit controller changes the Economizer position to help minimize the effect of supply fan speed changes on outdoor air volume levels
- Setpoint for outdoor air volume is established by field testing

NOTE - Not available with Demand Control Ventilation (CO₂ Sensor) or Building Pressure Control.

Building Pressure Control

- Maintains constant building pressure level
- Includes a static pressure transducer and outdoor static pressure assembly
- Using differential pressure information between the outdoor air and the building air, the Lennox® CORE unit controller changes the Economizer position to help maintain a constant building pressure

NOTE - Not available with Demand Control Ventilation (CO₂ Sensor) or Outdoor Air CFM Control.

EXHAUST

Factory or Field Installed

15 Downflow Barometric Relief Dampers

- Allow relief of excess air
- Aluminum blade dampers prevent blow back and outdoor air infiltration during off cycle
- Exhaust hood is factory installed when dampers are factory installed with Economizer
- Exhaust hood is furnished with dampers when ordered for field installation
- Bird screen furnished

16 Power Exhaust Fans

- Install internal to unit for downflow applications only with Economizer option
- Provides exhaust air pressure relief
- Interlocked to run when supply air blower is operating
- Fans run when outdoor air dampers are 50% open (adjustable)
- Motor is overload protected
- Dual propeller type fans are 20 in. diameter
- Five blades
- Two 1/3 HP motors
- SCCR rated

NOTE - Requires Economizer with furnished Outdoor Air Hood and Downflow Barometric Relief Dampers.

NOTE - SZVAV (Single Zone Variable Air Volume) and VAV (Variable Air Volume) models are equipped with 2-stage power exhaust fans. Power exhaust operates in 1st stage (one fan) up to 70% of supply air blower speed. Both exhaust fans operate in 2nd stage when supply air blower speed is above 70% (adjustable) of full speed.

Field Installed

Horizontal Barometric Relief Dampers

- For use when unit is configured for horizontal applications requiring an Economizer
- Allows relief of excess air
- Aluminum blade dampers prevent blow back and outdoor air infiltration during off cycle
- Field installed in return air duct
- Bird screen and hood furnished

OPTIONS / ACCESSORIES

OUTDOOR AIR OPTIONS

Factory or Field Installed

Motorized Outdoor Air Dampers

- Linked mechanical dampers
- Fully modulating spring return damper motor with plug-in connection
- 0 to 25% (fixed) outdoor air adjustable
- Installs in unit
- Outdoor air hood with bird screen included

NOTE - Outdoor Air Hood is shipped separately in the unit with factory installed dampers for field installation.

Field Installed

Manual Outdoor Air Damper

- Adjustable slide damper
- Installed in unit
- Outdoor air hood with bird screen included

ROOF CURBS

Field Installed

- Nailer strip furnished (downflow only)
- Mates to unit
- US National Roofing Contractors Approved
- Shipped knocked down

Downflow

Hybrid Roof Curbs

- Interlocking tabs fasten corners together
- No tools required
- Can also be fastened together with furnished hardware
- Available in 8, 14, 18, and 24 inch heights

Adjustable Pitch Curb

- Fully adjustable pitch curbs (3/4 in. per foot in any direction) provide a level platform for rooftop units allowing flexible installations on roofs with uneven or sloped angles
- Interlocking tabs fasten corners together
- No tools required
- Hardware is furnished to connect upper curb with lower curb
- Available in 14 inch height

Horizontal

- Meet National Roofing Code requirements
- Converts unit from downflow to horizontal (side) air flow
- Return air is on unit, supply air is on curb
- See dimension drawings
- Available in 26, 30, 37 and 41 inch heights

NOTE - Requires Horizontal Return Air Panel Kit.

NOTE - Optional Insulation Kit is available to help prevent sweating.

Adaptor Curbs (not shown)

- Curbs are regionally sourced
- Dimensions vary based upon the source

NOTE - Contact your local sales representative for a detailed cut sheet with applicable dimensions.

CEILING DIFFUSERS

Field Installed

Ceiling Diffusers (Flush or Step-Down)

- White powder coat finish on diffuser face and grilles
- Insulated UL listed duct liner
- Diffuser box has collars for duct connection
- Step-down diffusers have double deflection blades
- Flush diffusers have fixed blades
- Provisions for suspending
- Internally sealed to prevent recirculation
- Removable return air grille
- Adapts to T-bar ceiling grids or plaster ceilings

Transitions (Supply and Return)

- Used with diffusers
- Installs in roof curb
- Galvanized steel construction
- Flanges furnished for duct connection to diffusers
- Fully insulated

HUMIDITROL®+ DEHUMIDIFICATION SYSTEM OPTION

OVERVIEW

- Factory installed option designed to control humidity
- 17 • Humiditrol®+ utilizes advanced control algorithms, variable speed technology and a reheat coil to efficiently control humidity levels independent of room temperature
- Provides dehumidification on demand using ASHRAE 90.1 recommended method for comfort conditioning humidity control
- Unit comes equipped with one row reheat coil and solenoid valve

NOTE - A dehumidification demand from a relative humidity sensor, dehumidistat, a DDC controller or building automation system is required to control humidity

BENEFITS

- Improves indoor air quality
- Discharge air control for overcool protection
- Adjustable discharge air temperature setpoint
- Energy efficient dehumidification
- Modulating latent and sensible capacity
- Helps prevent damage due to high humidity levels
- Improves comfort levels by reducing space humidity levels

OPERATION

No Dehumidification Demand

- The unit will operate conventionally whenever there is a demand for cooling or heating and no dehumidification demand
- Free cooling is only permitted when there is no demand for dehumidification

Dehumidification Demand Only

- Reheat operation will initiate on a dehumidification demand and does not require a cooling demand
- The unit will operate in hot gas reheat dehumidification mode until the relative humidity of the conditioned space is below the setpoint
- A solenoid valve diverts hot gas from the compressor to the reheat coil
- The cooled and dehumidified air from the evaporator is reheated as it passes through the reheat coil
- The de-superheated and partially condensed refrigerant continues to the outdoor condenser coil where condensing is completed
- Unit will continue to operate in this mode until the dehumidification demand is satisfied
- The reheat coil is sized to provide optimal reheat performance without overheating supply air
- The compressor will modulate based on dehumidification load

Dehumidification and Cooling Demand (Thermostat/ Room Sensor Application)

- If both a dehumidification and a cooling demand occur, the system will operate in cooling until the cooling demand is satisfied
- Then the system will energize the dehumidification mode

NOTE - See Sequence of Operation for additional information.

HUMIDITROL™ + DEHUMIDIFICATION SYSTEM OPTION

REFRIGERANT SCHEMATIC (156 AND 180 MODELS)

NOTE - Two refrigerant circuits operate during reheat.

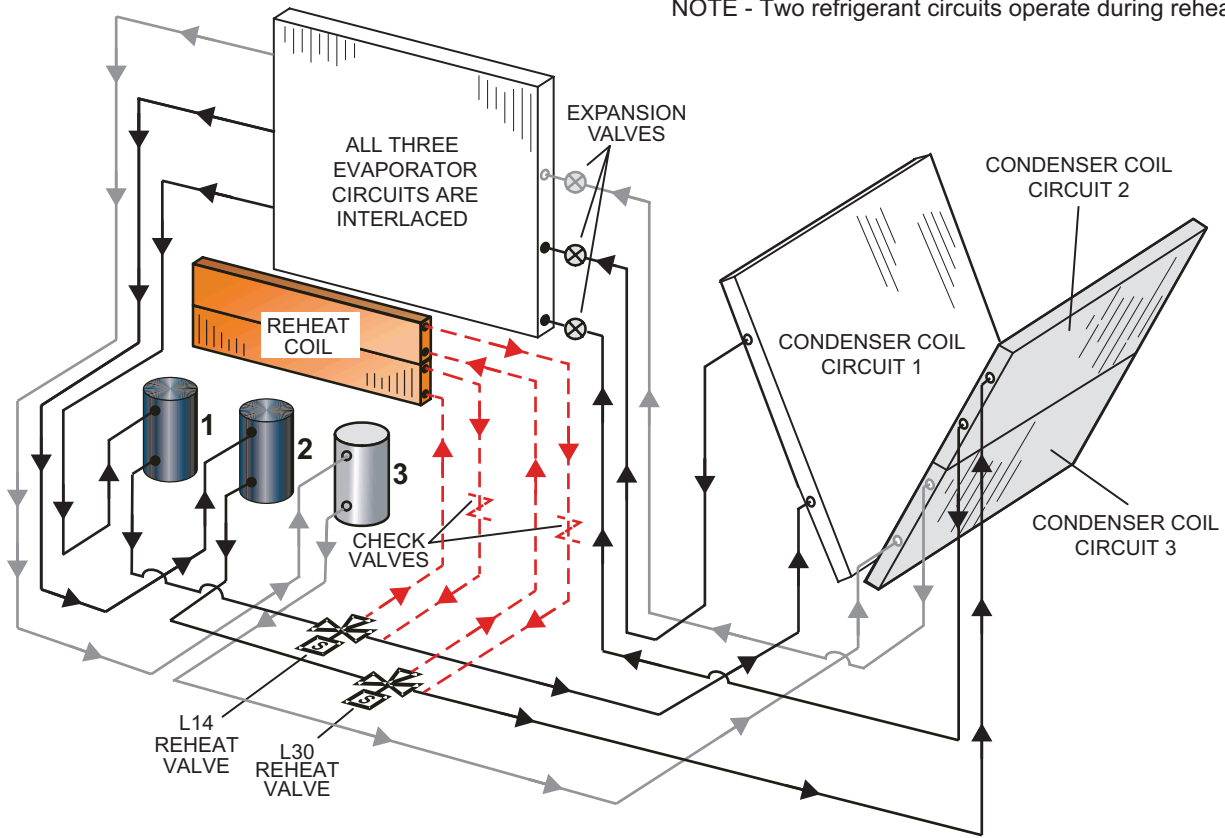

REFRIGERANT SCHEMATIC (210, 240 and 300 MODELS ONLY)

NOTE - Two refrigerant circuits operate during reheat.

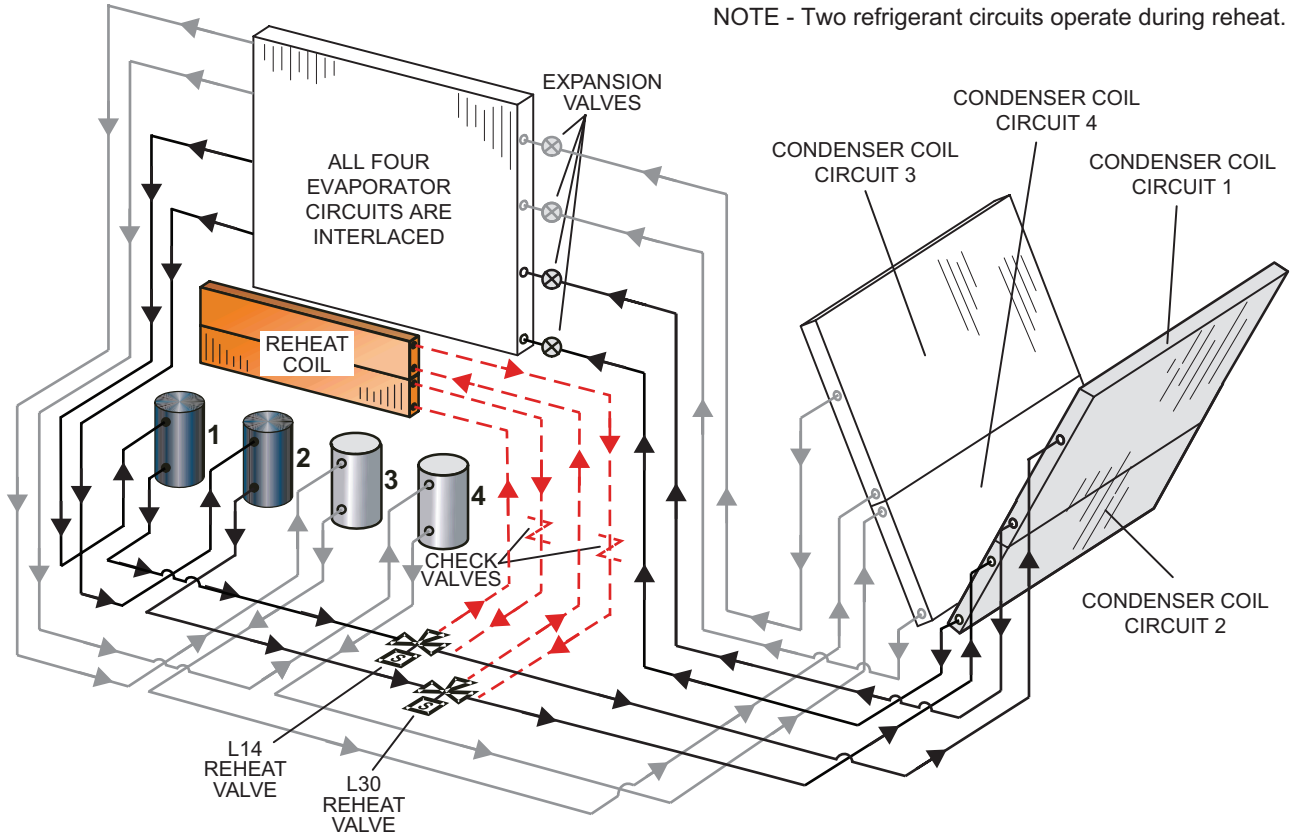

OPTIONAL CONVENTIONAL TEMPERATURE CONTROL SYSTEMS

CS8500 Commercial 7-Day Programmable Thermostat

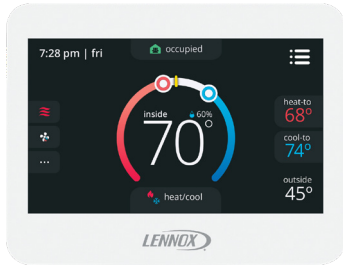

- Fully Communicating Sensor
- Full Color Touchscreen Interface
- Variable Speed System Control (On Compatible Units)
- Up To 4 Heat / 4 Cool
- Built-In Sensors For Temperature, Humidity And Optional CO₂
- Remote Sensor Options For Occupancy, Temperature
- BACnet Capable Options
- 5-2 or 7-Day Scheduling
- Smooth Setback Recovery
- Heat/Cool Auto-Changeover
- Four-Wire Installation
- FDD, ASHRAE, IECC Compliant

CS7500 Commercial 7-Day Programmable Thermostat



- Premium Universal Thermostat
- Full Color Touchscreen Interface
- Up To 4 Heat / 3 Cool
- Built-In Sensors For Temperature and Humidity
- Remote Sensors Options For Temperature, Discharge Air, Outdoor Air
- 5-2 or 7-Day Scheduling
- Smooth Setback Recovery
- Heat/Cool Auto-Changeover
- FDD, ASHRAE, IECC Compliant

CS3000 Commercial 5-2 Day Programmable Thermostat



- Conventional Multi-Stage Thermostat
- Intuitive Display
- Push-Button Operation
- Up To 2 Heat / 2 Cool
- Built-In Temperature Sensor
- Remote Temperature Sensing
- Up to 5-2 Day Scheduling
- Smooth Setback Recovery
- Heat/Cool Auto-changeover

Wired Temperature/Humidity Room Sensor (Non-Communicating)



- Terminal blocks for wiring connections
- Five-wire sensor connection
- Off-white plastic enclosure
- Non-adjustable
- Relative humidity range: 0 -100%
- +/- 3% Accuracy

OPTIONAL CONVENTIONAL TEMPERATURE CONTROL SYSTEMS

Description	Order Number
CS8500 Commercial 7 Day Programmable Thermostat	
CS8500 7-Day Thermostat	No CO ₂ Sensing 24K55
	With CO ₂ Sensing 24K53
Sensors/Accessories	¹ Remote non-adjustable wall-mount 10k 47W37
	¹ Remote non-adjustable wall-mount 11k 94L61
Sysbus Network Cable (Yellow) for CS8500 and LCS-5030 Wired Room Sensor	
Twisted pair 100% shielded communication cable, Red and Black	500 ft. box 27M19
22 AWG, yellow jacket, rated at 75°C, 300V, Plenum rated	1000 ft. box 94L63
Insulation - Low smoke PVC, NEC, CMP	2500 ft. roll 68M25
CS7500 Commercial 7-Day Programmable Thermostat	
CS7500 7-Day Thermostat	24K41
Sensors/Accessories	² Remote non-adjustable wall-mount 20k 47W36
	² Remote non-adjustable wall-mount 10k 47W37
	Remote non-adjustable discharge air (duct mount) 19L22
	Outdoor temperature sensor X2658
CS3000 Commercial 5-2 Day Programmable Thermostat	
CS3000 5-2 Day Thermostat	11Y05
Sensors/Accessories	Remote non-adjustable wall mount 10k averaging 47W37
	Thermostat wall mounting plate X2659
Universal Thermostat Guard with Lock (clear)	
	Inside Dimensions (H x W x D) 5-7/8 x 8-3/8 x 3 in. 39P21
Temperature/Humidity Room Sensor	
A335MT13AE1 Wired Temperature/Humidity Room Sensor (Non-Communicating)	21W06

¹ Up to nine of the same type remote temperature sensors can be connected in parallel.

² Remote wall-mount sensors can be applied in any of the following combinations:

One Sensor - (1) 47W36, Two Sensors - (2) 47W37, Three Sensors - (2) 47W36 and (1) 47W37

Four Sensors - (4) 47W36, Five Sensors - (3) 47W36 and (2) 47W37

SEQUENCE OF OPERATION

COOLING

A-Two-Stage Thermostat

1 - Economizer With Outdoor Air Suitable

Y1 Demand

- Compressors Off
- Blower Cooling Low
- Dampers Modulate

NOTE - If dampers are at maximum open for five minutes, blower runs at cooling high.

Y2 Demand

- Compressors Modulate
- Blower Cooling High
- Dampers Maximum Open

2 - No Economizer or Outdoor Air Not Suitable

Y1 Demand

- Compressors Modulate
- Blower Cooling Low
- Dampers Minimum Position

Y2 Demand

- Compressors Modulate
- Blower Cooling High
- Dampers Minimum Position

B-Three-Stage Thermostat

1 - Economizer With Outdoor Air Suitable

Y1 Demand

- Compressors Off
- Blower Cooling Low
- Dampers Modulate

NOTE - If dampers are at maximum open for five minutes, blower runs at cooling intermediate.

Y2 Demand

- Compressors Modulate
- Blower Cooling Intermediate
- Dampers Maximum Open

Y3 Demand

- Compressors Modulate
- Blower Cooling High
- Dampers Maximum Open

SEQUENCE OF OPERATION

COOLING (CONTINUED)

2 - No Economizer or Outdoor Air Not Suitable

Y1 Demand

- Compressors Modulate
- Blower Cooling Low
- Dampers Minimum Position

Y2 Demand

- Compressors Modulate
- Blower Cooling Intermediate
- Dampers Minimum Position

Y3 Demand

- Compressors Modulate
- Blower Cooling High
- Dampers Minimum Position

C - Room Sensor

1 - Economizer With Outdoor Air Suitable

- Compressors Off
- Blower Modulates
- Dampers Modulate

NOTE - If dampers are at maximum open for five minutes, compressors are energized and the blower modulates.

2 - No Economizer or Outdoor Air Not Suitable

- Compressors Modulate
- Blower Modulates
- Dampers Minimum Position

NOTE - Free cooling is locked out when a dehumidification demand is received. The unit operates in dehumidification.

HEATING

Heating Mode: Thermostat or Room Sensor

NOTE - HEATING MODE IS THE SAME FOR ALL CONTROL OPTIONS.

W1 Demand:

- 1st stage electric heat is energized and the supply air blower operates at heating speed

W2 Demand:

- 2nd stage electric heat is energized and the supply air blower operates at heating speed (45, 60 or 90 kW electric heat option only)

SEQUENCE OF OPERATION

HUMIDITROL™+

A - Thermostat Mode With 24V Humidistat

Dehumidification Demand (DI4) and No Cooling Demand

Compressor 1 operates at 100% and reheat valve is energized, blower and outdoor fans modulate to maintain indoor coil and discharge air temperatures, all other compressors are off.

NOTE: After 5 minutes of only a Dehumidification demand (DI4), compressor 2 is turned on and reheat valve is energized.

Y1 and DI4 Demand

Compressors are modulating, blower is on cooling low, and the reheat valves are de-energized.

Y2 and DI4 Demand

Compressors are modulating, blower is on cooling high, and the reheat valves are de-energized.

B - Thermostat Mode With Zone Relative Humidity Sensor

Dehumidification Demand (RH% Setpoint < Zone RH% < RH% Setpoint +2%) and No Cooling Demand

Compressor 1 modulates based on zone relative humidity, blower and outdoor fans modulate to maintain indoor coil and discharge air temperatures, reheat valve is energized. All other compressors are off.

Dehumidification Demand (RH% Setpoint < Zone RH% for 5 minutes or Zone RH% > RH% Setpoint +2%) and No Cooling Demand

Compressor 1 modulates based on zone relative humidity and reheat valve is energized, Compressor 2 is on and reheat valve is energized, blower and outdoor fans modulate to maintain indoor coil and discharge air temperatures. All other compressors are off.

Y1 and Dehumidification Demand

Compressors are modulating, blower is on low, and the reheat valves are de-energized.

Y2 and Dehumidification Demand

Compressors are modulating, blower is on high, reheat valves are de-energized.

C - Room Sensor Mode With 24V Humidistat

Dehumidification Demand (DI4) and No Cooling Demand

Compressor 1 operates at 100%, blower and outdoor fans modulate to maintain indoor coil and discharge air temperatures, reheat valve is energized.

NOTE: After 5 minutes of only a Dehumidification demand (DI4), compressor 2 is turned on and the reheat valve is energized.

Cooling and Dehumidification Demand

Compressors are modulating, blower is modulating, reheat valves are de-energized.

D - Room Sensor Mode With Zone Relative Humidity Sensor

Dehumidification Demand (RH% Setpoint < Zone RH% < RH% Setpoint +2%) and No Cooling Demand

Compressor 1 modulates based on zone relative humidity, blower and outdoor fans modulate to maintain indoor coil and discharge air temperatures, reheat valve is energized. All other compressors are off.

Dehumidification Demand (RH% Setpoint < Zone RH% for 5 minutes or Zone RH% > RH% Setpoint +2%) and No Cooling Demand

Compressor 1 modulates based on zone relative humidity and reheat valve is energized, Compressor 2 is on and reheat valve is energized, blower and outdoor fans modulate to maintain indoor coil and discharge air temperatures. All other compressors are off.

Cooling and Dehumidification Demand

Compressors are modulating, blower is modulating, and the reheat valves are de-energized.

OPTIONS / ACCESSORIES

Item Description	Order Number	Size					
		156	180	210	240	300	
COOLING SYSTEM							
Condensate Drain Trap	PVC	22H54	X	X	X	X	X
	Copper	76W27	X	X	X	X	X
Corrosion Protection	Factory		O	O	O	O	O
Drain Pan Overflow Switch	21Z07		OX	OX	OX	OX	OX
BLOWER - SUPPLY AIR							
Blower Option							
	SZVAV (Single Zone Variable Air Volume) - With VFD Bypass Control	Factory	O	O	O	O	O
	SZVAV (Single Zone Variable Air Volume) - Without VFD Bypass Control	Factory	O	O	O	O	O
	VAV (Variable Air Volume) - Without VFD Bypass Control	Factory	O	O	O	O	O
Motors	Belt Drive (standard efficiency) - 3 HP	Factory	O	O	O		
	Belt Drive (standard efficiency) - 5 HP	Factory	O	O	O	O	O
	Belt Drive (standard efficiency) - 7.5 HP	Factory		O	O	O	O
	Belt Drive (standard efficiency) - 10 HP	Factory				O	O
Drive Kits See Blower Data Tables for usage and selection	Kit #1 535-725 rpm	Factory	O	O	O		
	Kit #2 710-965 rpm	Factory	O	O	O		
	Kit #3 685-856 rpm	Factory	O	O	O	O	O
	Kit #4 850-1045 rpm	Factory	O	O	O	O	O
	Kit #5 945-1185 rpm	Factory	O	O	O	O	O
	Kit #6 850-1045 rpm	Factory		O	O	O	O
	Kit #7 945-1185 rpm	Factory		O	O	O	O
	Kit #8 1045-1285 rpm	Factory		O	O	O	O
	Kit #10 1045-1285 rpm	Factory				O	O
	Kit #11 1135-1330 rpm	Factory				O	O
		Blower Belt Auto-Tensioner	24B80	X	X	X	X
CABINET							
Burglar Bars	(US)	44N20	X	X	X	X	X
	(CA)	X2889	X	X	X	X	X
Combination Coil/Hail Guards	23U71		OX	OX	OX	OX	OX
CONTROLS							
Commercial Controls	LonTalk® Module - For Lennox® CORE Control System	54W27	OX	OX	OX	OX	OX
	Novar® LSE	Factory	O	O	O	O	O
Dirty Filter Switch		53W68	OX	OX	OX	OX	OX
Fresh Air Tempering		21Z08	OX	OX	OX	OX	OX
Smoke Detector - Supply or Return (Power board and one sensor)		22H56	OX	OX	OX	OX	OX
Smoke Detector - Supply and Return (Power board and two sensors)		22H57	OX	OX	OX	OX	OX

NOTE - Order numbers shown are for ordering optional accessories if a field installed option is available.

OX = Configure To Order (Factory Installed) or Field Installed

O = Configure To Order (Factory Installed)

X = Field Installed

OPTIONS / ACCESSORIES

Item Description	Order Number	Size					
		156	180	210	240	300	
INDOOR AIR QUALITY							
Air Filters							
Healthy Climate® High Efficiency Air Filters 24 x 24 x 2 in.	MERV 8 (Order 6)	54W67	OX	OX	OX	OX	OX
	MERV 13 (Order 6)	52W40	OX	OX	OX	OX	OX
	MERV 16 (Order 6)	21U52	OX	OX	OX	OX	OX
Replacement Media Filter With Metal Mesh Frame 24 x 24 x 2 in. (includes non-pleated filter media)	(Order 6)	44N61	X	X	X	X	X
Indoor Air Quality (CO₂) Sensors							
Sensor - Wall-mount, off-white plastic cover with LCD display		24C58	X	X	X	X	X
Sensor - Wall-mount, off-white plastic cover, no display		23V86	X	X	X	X	X
Sensor - Black plastic case, LCD display, rated for plenum mounting		87N52	X	X	X	X	X
Sensor - Black plastic case, no display, rated for plenum mounting		23V87	X	X	X	X	X
CO ₂ Sensor Duct Mounting Kit - for downflow applications		23Y47	X	X	X	X	X
Aspiration Box - for duct mounting non-plenum rated CO ₂ sensors (24C58)		90N43	X	X	X	X	X
Needlepoint Bipolar Ionization (NPBI)							
Needlepoint Bipolar Ionization (NPBI) Kit		21U37	X	X	X		
		21U38				X	
		21U39					X
UVC Germicidal Light Kit							
¹ Healthy Climate® UVC Light Kit (110/230V-1Ph)		21A94	X	X	X	X	X
Step-Down Transformer	460V primary, 230V secondary	10H20	X	X	X	X	X
	575V primary, 230V secondary	10H21	X	X	X	X	X
ELECTRICAL							
Voltage 60 Hz	208/230V - 3 phase	Factory	O	O	O	O	O
	460V - 3 phase	Factory	O	O	O	O	O
	575V - 3 phase	Factory	O	O	O	O	O
HACR Circuit Breakers		Factory	O	O	O	O	O
Disconnect Switch (see Electric Heat Tables for usage)	80 amp	54W85	OX	OX	OX	OX	OX
	150 amp	54W86	OX	OX	OX	OX	OX
	250 amp	54W87	OX	OX	OX	OX	OX
² Short-Circuit Current Rating (SCCR) of 100kA (includes Phase/Voltage Detection)		Factory	O	O	O	O	O
GFI Service Outlets	15 amp non-powered, field-wired (208/230V, 460V only)	74M70	OX	OX	OX	OX	OX
	15 amp factory-wired and powered (208/230V, 460V only)	Factory	O	O	O	O	O
	³ 20 amp non-powered, field-wired (208/230V, 460V, 575V)	67E01	X	X	X	X	X
	³ 20 amp non-powered, field-wired (575V only)	Factory	O	O	O	O	O
Weatherproof Cover for GFI		10C89	X	X	X	X	X
¹ Lamps operate on 110-230V single-phase power supply. Step-down transformer may be ordered separately for 460V and 575V units. Alternately, 110V power supply may be used to directly power the UVC ballast(s). ² Disconnect Switch not available with higher SCCR option. Short-Circuit Current Rating option not available on field installed electric heat or 90kW electric heat (208/240V) models. ³ Canada requires a minimum 20 amp circuit. Select 20 amp, non-powered, field wired GFI.							
NOTE - Order numbers shown are for ordering optional accessories if a field installed option is available.							
OX = Configure To Order (Factory Installed) or Field Installed							
O = Configure To Order (Factory Installed)							
X = Field Installed							

OPTIONS / ACCESSORIES

Item Description	Order Number	Size					
		156	180	210	240	300	
ELECTRIC HEAT							
15 kW	208/240V-3ph	30U62	OX	OX	OX	OX	OX
	460V-3ph	30U63	OX	OX	OX	OX	OX
	575V-3ph	30U64	OX	OX	OX	OX	OX
30 kW	208/240V-3ph	30U65	OX	OX	OX	OX	OX
	460V-3ph	30U66	OX	OX	OX	OX	OX
	575V-3ph	30U67	OX	OX	OX	OX	OX
45 kW	208/240V-3ph	30U71	OX	OX	OX	OX	OX
	460V-3ph	30U72	OX	OX	OX	OX	OX
	575V-3ph	30U73	OX	OX	OX	OX	OX
60 kW	208/240V-3ph	30U77	OX	OX	OX	OX	OX
	460V-3ph	30U78	OX	OX	OX	OX	OX
	575V-3ph	30U79	OX	OX	OX	OX	OX
90 kW	208/240V-3ph	30U83			OX	OX	OX
	460V-3ph	30U84			OX	OX	OX
	575V-3ph	30U85			OX	OX	OX

ECONOMIZER

High Performance Economizer (Approved for California Title 24 Building Standards / AMCA Class 1A Certified)

High Performance Economizer (Downflow or Horizontal)	Order 2	22J18	OX	OX	OX	OX	OX
Includes Economizer Dampers with Outdoor Air Hood							
Downflow Applications - Use furnished Outdoor Air Hood - Order Downflow Barometric Relief Dampers with Exhaust Hood separately							
Horizontal Applications - Use furnished Outdoor Air Hood - Order Horizontal Barometric Relief Dampers with Exhaust Hood separately							

Economizer Controls

Differential Enthalpy (Not for Title 24)	Order 2	21Z09	OX	OX	OX	OX	OX
Sensible Control	Sensor is Furnished	Factory	O	O	O	O	O
Single Enthalpy (Not for Title 24)		21Z09	OX	OX	OX	OX	OX
Global Control	Sensor Field Provided	Factory	O	O	O	O	O
Building Pressure Control		13J77	X	X	X	X	X
Outdoor Air CFM Control		13J76	X	X	X	X	X

Barometric Relief Dampers With Exhaust Hood (required with economizer)

Downflow Barometric Relief Dampers		54W78	OX	OX	OX	OX	OX
Horizontal Barometric Relief Dampers		16K99	X	X	X	X	X

OUTDOOR AIR

Outdoor Air Dampers With Outdoor Air Hood

Motorized		22J27	OX	OX	OX	OX	OX
Manual		13U05	X	X	X	X	X

4 POWER EXHAUST (DOWNFLOW APPLICATIONS ONLY)

Standard Static, SCCR Rated	208/230V	22H90	OX	OX	OX	OX	OX
	460V	22H91	OX	OX	OX	OX	OX
	575V	22V34	OX	OX	OX	OX	OX

HUMIDITROL™+ HOT GAS REHEAT OPTION - SZVAV MODELS ONLY

Humiditrol®+ Dehumidification Option	Factory	O	O	O	O	O
--------------------------------------	---------	---	---	---	---	---

⁴ Field installed Power Exhaust requires Economizer with Outdoor Air Hood and Downflow Barometric Relief Dampers with Exhaust Hood. Must be ordered separately.

NOTE - Order numbers shown are for ordering optional accessories if a field installed option is available.

OX = Configure To Order (Factory Installed) or Field Installed

O = Configure To Order (Factory Installed)

X = Field Installed

OPTIONS / ACCESSORIES

Item Description	Order Number	Size				
		156	180	210	240	300
ROOF CURBS						
Hybrid Roof Curbs, Downflow						
8 in. height curb	11F58	X	X	X	X	X
14 in. height curb	11F59	X	X	X	X	X
18 in. height curb	11F60	X	X	X	X	X
24 in. height curb	11F61	X	X	X	X	X
Adjustable Pitch Curb						
14 in. height curb	43W26	X	X	X	X	X
Standard Roof Curbs, Horizontal - Requires Horizontal Return Air Panel Kit						
26 in. height - slab applications	11T89	X	X	X	X	
30 in. height - slab applications	11T90					X
37 in. height - rooftop applications	11T96	X	X	X	X	
41 in. height - rooftop applications	11T97					X
Insulation Kit For Standard Horizontal Roof Curbs						
for 26 in. height curb	73K32	X	X	X	X	
for 30 in. height curb	73K33					X
for 37 in. height curb	73K34	X	X	X	X	
for 41 in. height curb	73K35					X
Horizontal Return Air Panel Kit						
Required for Horizontal Applications with Roof Curb	87M00	X	X	X	X	X
CEILING DIFFUSERS						
Step-Down - Order one	RTD11-185S	13K63	X	X		
	RTD11-275S	13K64			X	X
Flush - Order one	FD11-185S	13K58	X	X		
	FD11-275S	13K59			X	X
Transitions (Supply and Return) - Order one	C1DIFF33C-1	12X68	X	X		
	C1DIFF34C-1	12X70			X	X

NOTE - Order numbers shown are for ordering optional accessories if a field installed option is available.

OX = Configure To Order (Factory Installed) or Field Installed

O = Configure To Order (Factory Installed)

X = Field Installed

SPECIFICATIONS **13 TON**

Model	LCM156U5M		LCM156U5V	
Nominal Tonnage	13 Ton		13 Ton	
Efficiency Type	Ultra-High		Ultra-High	
Blower Type	SZVAV (Single Zone Variable Air Volume)		VAV (Variable Air Volume)	
Cooling Performance	Gross Cooling Capacity (Btuh)	154,000	154,000	
	¹ Net Cooling Capacity (Btuh)	150,000	150,000	
	¹ AHRI Rated Air Flow (cfm)	4100	4100	
	¹ IEER (Btuh/Watt)	19.0	18.5	
	¹ EER (Btuh/Watt)	12.2	12.2	
	Total Unit Power (kW)	12.3	12.3	
Sound Rating Number	dBA	86	86	
Refrigerant Charge	Refrigerant Type	R-454B	R-454B	
	Without Reheat Option	Circuit 1	6 lbs. 3 oz.	6 lbs. 3 oz.
		Circuit 2	5 lbs. 5 oz.	5 lbs. 5 oz.
		Circuit 3	5 lbs. 11 oz.	5 lbs. 11 oz.
	With Reheat Option	Circuit 1	6 lbs. 3 oz.	---
		Circuit 2	5 lbs. 5 oz.	---
		Circuit 3	5 lbs. 11 oz.	---
Electric Heating Options Available	15-30-45-60 kW			
Compressor Type (number)	Variable Capacity Scroll (1) Fixed Capacity Scroll (2)			
Outdoor Coils	Net face area - ft. ²	55.2	55.2	
	Rows	1	1	
	Fins - in.	20	20	
Outdoor Coil Fans	Motor HP (number and type)	1/3 (4 ECM)	1/3 (4 ECM)	
	Rpm	450-1075	450-1075	
	Watts	155 - 1150	155 - 1150	
	Diameter (Number) - in.	(4) 24	(4) 24	
	Blades	3	3	
	Total Air volume - cfm	16,000	16,000	
Indoor Coils	Net face area - ft. ²	21.40	21.40	
	Tube diameter - in.	3/8	3/8	
	Rows	3	3	
	Fins - in.	14	14	
	Condensate drain size (NPT) - in.	(1) 1	(1) 1	
	Expansion device type	Balanced Port Thermostatic Expansion Valve,removable power head		
² Indoor Blower and Drive Selection	Nominal motor HP	3, 5		
	Maximum usable motor HP (US)	3.45, 5.75		
	Motor - Drive kit number	3 HP		
		Kit 1 535-725 rpm		
		Kit 2 710-965 rpm		
	5 HP			
	Kit 3 685-856 rpm			
	Kit 4 850-1045 rpm			
	Kit 5 945-1185 rpm			
	Blower wheel nominal diameter x width - in.	(2) 15 x 15 in.	(2) 15 x 15 in.	
Filters	Type of filter	MERV 4, Disposable		
	Number and size - in.	(6) 24 x 24 x 2		
Line voltage data (Volts-Phase-Hz)	208/230-3-60, 460-3-60, 575-3-60			

NOTE - Net capacity includes evaporator blower motor heat deduction. Gross capacity does not include evaporator blower motor heat deduction.

¹ AHRI Certified to AHRI Standard 340/360; 95°F outdoor air temperature and 80°F db/67°F wb entering evaporator air; minimum external duct static pressure.

² Using total air volume and system static pressure requirements determine from blower performance tables rpm and motor output required. Maximum usable output of motors furnished are shown. In Canada, nominal motor output is also maximum usable motor output. If motors of comparable output are used, be sure to keep within the service factor limitations outlined on the motor nameplate.

NOTE – Blower motor service factor = 1.0.

SPECIFICATIONS

15 TON | 17.5 TON

Model		LCM180U5M	LCM180U5V	LCM210U5M	LCM210U5V	
Nominal Tonnage		15 Ton	15 Ton	17.5 Ton	17.5 Ton	
Efficiency Type		Ultra-High	Ultra-High	Ultra-High	Ultra-High	
Blower Type		SZVAV (Single Zone Variable Air Volume)	VAV (Variable Air Volume)	SZVAV (Single Zone Variable Air Volume)	VAV (Variable Air Volume)	
Cooling Performance	Gross Cooling Capacity (Btuh)	176,000	176,000	206,000	206,000	
	¹ Net Cooling Capacity (Btuh)	172,000	172,000	200,000	200,000	
	¹ AHRI Rated Air Flow (cfm)	5250	5250	6100	6100	
	¹ IEER (Btuh/Watt)	19.0	17.5	18.8	18.0	
	¹ EER (Btuh/Watt)	12.2	12.2	12.2	12.2	
	Total Unit Power (kW)	14.1	14.1	16.4	16.4	
Sound Rating Number	dBA	86	86	90	90	
Refrigerant Charge	Refrigerant Type	R-454B	R-454B	R-454B	R-454B	
	Without Reheat Option	Circuit 1	6 lbs. 4 oz.	6 lbs. 4 oz.	5 lbs. 14 oz.	5 lbs. 14 oz.
		Circuit 2	6 lbs. 2 oz.	6 lbs. 2 oz.	5 lbs. 12 oz.	5 lbs. 12 oz.
		Circuit 3	5 lbs. 8 oz.	5 lbs. 8 oz.	5 lbs. 0 oz.	5 lbs. 0 oz.
		Circuit 4	- - -	- - -	5 lbs. 4 oz.	5 lbs. 4 oz.
	With Reheat Option	Circuit 1	6 lbs. 4 oz.	- - -	5 lbs. 14 oz.	- - -
		Circuit 2	6 lbs. 2 oz.	- - -	5 lbs. 12 oz.	- - -
		Circuit 3	5 lbs. 8 oz.	- - -	5 lbs. 0 oz.	- - -
		Circuit 4	- - -	- - -	5 lbs. 4 oz.	- - -
Electric Heating Options Available		15-30-45-60 kW		15-30-45-60-90 kW		
Compressor Type (number)		Variable Capacity Scroll (1) Fixed Capacity Scroll (2)		Variable Capacity Scroll (1) Fixed Capacity Scroll (3)		
Outdoor Coils	Net face area - ft. ²	55.2	55.2	55.2	55.2	
	Rows	1	1	1	1	
	Fins - in.	20	20	20	20	
Outdoor Coil Fans	Motor HP (number and type)	1/3 (4 ECM)	1/3 (4 ECM)	1/3 (6 ECM)	1/3 (6 ECM)	
	Rpm	280-1075	280-1075	640-950	640-950	
	Watts	150 -1350	150 -1350	290 -1250	290 -1250	
	Diameter (Number) - in.	(4) 24	(4) 24	(6) 24	(6) 24	
	Blades	3	3	3	3	
	Total Air volume - cfm	16,000	16,000	18,600	18,600	
Indoor Coils	Net face area - ft. ²	21.40	21.40	21.40	21.40	
	Tube diameter - in.	3/8	3/8	3/8	3/8	
	Rows	3	3	3	3	
	Fins - in.	14	14	14	14	
	Condensate drain size (NPT) - in.	(1) 1	(1) 1	(1) 1	(1) 1	
	Expansion device type	Balanced Port Thermostatic Expansion Valve, removable power head				
² Indoor Blower and Drive Selection	Nominal motor HP	3, 5, 7.5				
	Maximum usable motor HP (US)	3.45, 5.75, 8.62				
	Motor - Drive kit number	3 HP				
		Kit 1 535-725 rpm				
		Kit 2 710-965 rpm				
		5 HP				
		Kit 3 685-856 rpm				
		Kit 4 850-1045 rpm				
		Kit 5 945-1185 rpm				
		7.5 HP				
Blower wheel nominal diameter x width - in.	Kit 6 850-1045 rpm					
	Kit 7 945-1185 rpm					
Filters	Type of filter	MERV 4, Disposable				
	Number and size - in.	(6) 24 x 24 x 2				
Line voltage data (Volts-Phase-Hz)		208/230-3-60, 460-3-60, 575-3-60				

NOTE - Net capacity includes evaporator blower motor heat deduction. Gross capacity does not include evaporator blower motor heat deduction.

¹ AHRI Certified to AHRI Standard 340/360; 95°F outdoor air temperature and 80°F db/67°F wb entering evaporator air; minimum external duct static pressure.

² Using total air volume and system static pressure requirements determine from blower performance tables rpm and motor output required. Maximum usable output of motors furnished are shown. In Canada, nominal motor output is also maximum usable motor output. If motors of comparable output are used, be sure to keep within the service factor limitations outlined on the motor nameplate.

NOTE - Blower motor service factor = 1.0.

SPECIFICATIONS **20 TON | 25 TON**

Model		LCM240U5M	LCM240U5V	LCM300U5M	LCM300U5V	
Nominal Tonnage		20 Ton	20 Ton	25 Ton	25 Ton	
Efficiency Type		Ultra-High	Ultra-High	Ultra-High	Ultra-High	
Blower Type		SZVAV (Single Zone Variable Air Volume)	VAV (Variable Air Volume)	SZVAV (Single Zone Variable Air Volume)	VAV (Variable Air Volume)	
Cooling Performance	Gross Cooling Capacity (Btuh)	235,000	235,000	277,000	277,000	
	¹ Net Cooling Capacity (Btuh)	228,000	228,000	270,000	270,000	
	¹ AHRI Rated Air Flow (cfm)	6450	6450	7400	7400	
	¹ IEER (Btuh/Watt)	18.4	17.5	17.5	16.5	
	¹ EER (Btuh/Watt)	12.2	12.2	10.8	10.8	
	Total Unit Power (kW)	18.7	18.7	25	25	
Sound Rating Number	dBA	90	90	90	90	
Refrigerant Charge	Refrigerant Type	R-454B	R-454B	R-454B	R-454B	
	Without Reheat Option	Circuit 1	6 lbs. 1 oz.	6 lbs. 1 oz.	6 lbs. 12 oz.	6 lbs. 12 oz.
		Circuit 2	5 lbs. 11 oz.	5 lbs. 11 oz.	6 lbs. 12 oz.	6 lbs. 12 oz.
		Circuit 3	5 lbs. 2 oz.	5 lbs. 2 oz.	6 lbs. 3 oz.	6 lbs. 3 oz.
		Circuit 4	5 lbs. 8 oz.	5 lbs. 8 oz.	5 lbs. 15 oz.	5 lbs. 15 oz.
	With Reheat Option	Circuit 1	6 lbs. 14 oz.	---	6 lbs. 12 oz.	---
		Circuit 2	6 lbs. 13 oz.	---	6 lbs. 12 oz.	---
		Circuit 3	4 lbs. 11 oz.	---	6 lbs. 3 oz.	---
		Circuit 4	4 lbs. 13 oz.	---	5 lbs. 15 oz.	---
Electric Heat Options Available		15-30-45-60-90 kW				
Compressor Type (number)		Variable Capacity Scroll (1) Fixed Capacity Scroll (3)				
Outdoor Coils	Net face area - ft. ²	55.2	55.2	55.2	55.2	
	Number of rows	1	1	1	1	
	Fins - in.	20	20	20	20	
Outdoor Coil Fans	Motor HP (number and type)	1/3 (6 ECM)	1/3 (6 ECM)	1/3 (6 ECM)	1/3 (6 ECM)	
	Rpm	450 - 950	450 - 950	515 - 1000	515 - 1000	
	Watts	130 -1530	130 -1530	180 - 1730	180 - 1730	
	Diameter (Number) - in.	(6) 24	(6) 24	(6) 24	(6) 24	
	Blades	3	3	3	3	
	Total Air volume - cfm	18,000	18,000	18,300	18,300	
Indoor Coils	Net face area - ft. ²	21.40	21.40	21.40	21.40	
	Tube diameter - in.	3/8	3/8	3/8	3/8	
	Rows	4	4	4	4	
	Fins - in.	14	14	14	14	
	Condensate drain size (NPT) - in.	(1) 1	(1) 1	(1) 1	(1) 1	
	Expansion device type	Balanced Port Thermostatic Expansion Valve,removable power head				
² Indoor Blower and Drive Selection	Nominal motor HP	5, 7.5, 10				
	Maximum usable motor HP (US)	5.75, 8.62, 11.5				
	Motor - Drive kit number	5 HP Kit 3 685-856 rpm Kit 4 850-1045 rpm Kit 5 945-1185 rpm				
		7.5 HP Kit 6 850-1045 rpm Kit 7 945-1185 rpm Kit 8 1045-1285 rpm				
		10 HP Kit 7 945-1185 rpm Kit 10 1045-1285 rpm Kit 11 1135-1330 rpm				
	Blower wheel nominal diameter x width - in.	(2) 15 x 15				
	Filters	Type of filter	MERV 4, Disposable			
		Number and size - in.	(6) 24 x 24 x 2			
	Line voltage data (Volts-Phase-Hz)		208/230-3-60, 460-3-60, 575-3-60			

NOTE - Net capacity includes evaporator blower motor heat deduction. Gross capacity does not include evaporator blower motor heat deduction.

¹ AHRI Certified to AHRI Standard 340/360; 95°F outdoor air temperature and 80°F db/67°F wb entering evaporator air; minimum external duct static pressure.

² Using total air volume and system static pressure requirements determine from blower performance tables rpm and motor output required. Maximum usable output of motors furnished are shown. In Canada, nominal motor output is also maximum usable motor output. If motors of comparable output are used, be sure to keep within the service factor limitations outlined on the motor nameplate.

NOTE – Blower motor service factor = 1.0.

COOLING RATINGS

NOTE – For Temperatures and Capacities not shown in tables, see bulletin – Cooling Unit Rating Table Correction Factor Data in Miscellaneous Engineering Data section.

13 TON - LCM156U5M/V (ONE COMPRESSOR OPERATING)

Entering Wet Bulb Temperature	Total Air Volume	Outdoor Air Temperature Entering Outdoor Coil																				
		65°F						75°F					85°F					95°F				
		Total Cool Cap.	Comp. Motor Input	Sensible To Total Ratio (S/T)			Total Cool Cap.	Comp. Motor Input	Sensible To Total Ratio (S/T)			Total Cool Cap.	Comp. Motor Input	Sensible To Total Ratio (S/T)			Total Cool Cap.	Comp. Motor Input	Sensible To Total Ratio (S/T)			
				Dry Bulb					Dry Bulb					Dry Bulb					Dry Bulb			
		cfm	kBtuh	kW	75°F	80°F	85°F	kBtuh	kW	75°F	80°F	85°F	kBtuh	kW	75°F	80°F	85°F	kBtuh	kW	75°F	80°F	85°F
63°F	1200	31.3	0.76	0.83	0.98	1	29.4	0.94	0.83	0.98	1	27.5	1.17	0.84	0.99	1	25.6	1.43	0.86	1	1	
	1500	32.9	0.74	0.89	1	1	31.1	0.94	0.91	1	1	29.2	1.17	0.93	1	1	27.3	1.43	0.94	1	1	
	1800	34.5	0.73	0.95	1	1	32.6	0.93	0.96	1	1	30.7	1.17	0.96	1	1	28.7	1.43	0.97	1	1	
67°F	1200	33	0.74	0.53	0.78	0.96	31.1	0.94	0.53	0.79	0.97	29.1	1.17	0.52	0.8	0.98	27.1	1.43	0.52	0.82	0.98	
	1500	34.6	0.73	0.57	0.85	0.99	32.5	0.93	0.57	0.87	0.99	30.5	1.17	0.57	0.89	1	28.4	1.43	0.57	0.93	1	
	1800	35.7	0.72	0.62	0.93	1	33.6	0.92	0.62	0.94	1	31.5	1.16	0.62	0.95	1	29.3	1.43	0.63	0.96	1	
71°F	1200	35	0.73	0.25	0.5	0.74	33	0.93	0.23	0.5	0.75	31	1.17	0.21	0.5	0.76	28.9	1.43	0.18	0.49	0.78	
	1500	36.5	0.72	0.25	0.55	0.81	34.5	0.92	0.23	0.55	0.83	32.3	1.17	0.21	0.55	0.85	30.1	1.43	0.19	0.55	0.87	
	1800	37.7	0.71	0.26	0.59	0.88	35.5	0.92	0.24	0.6	0.92	33.3	1.17	0.23	0.61	0.94	31	1.43	0.21	0.61	0.95	

NOTE - Compressor operating at maximum capacity.

13 TON - LCM156U5M/V (TWO COMPRESSORS OPERATING)

Entering Wet Bulb Temperature	Total Air Volume	Outdoor Air Temperature Entering Outdoor Coil																				
		65°F						75°F					85°F					95°F				
		Total Cool Cap.	Comp. Motor Input	Sensible To Total Ratio (S/T)			Total Cool Cap.	Comp. Motor Input	Sensible To Total Ratio (S/T)			Total Cool Cap.	Comp. Motor Input	Sensible To Total Ratio (S/T)			Total Cool Cap.	Comp. Motor Input	Sensible To Total Ratio (S/T)			
				Dry Bulb					Dry Bulb					Dry Bulb					Dry Bulb			
		cfm	kBtuh	kW	75°F	80°F	85°F	kBtuh	kW	75°F	80°F	85°F	kBtuh	kW	75°F	80°F	85°F	kBtuh	kW	75°F	80°F	85°F
63°F	3120	114	4.08	0.72	0.84	0.93	108.3	4.74	0.73	0.85	0.94	103	5.46	0.74	0.86	0.95	97.6	6.27	0.75	0.87	0.96	
	3900	120.8	4.06	0.77	0.88	0.97	114.6	4.74	0.79	0.89	0.98	109.4	5.48	0.79	0.9	0.99	103.3	6.29	0.79	0.91	1	
	4680	126.3	4.05	0.8	0.92	0.99	120	4.74	0.82	0.93	1	114.2	5.48	0.82	0.94	1	108.3	6.31	0.83	0.95	1	
67°F	3120	120.3	4.05	0.55	0.69	0.82	113.9	4.73	0.54	0.7	0.82	108.3	5.47	0.54	0.7	0.83	102.4	6.28	0.53	0.7	0.84	
	3900	126.2	4.04	0.56	0.74	0.86	119.4	4.72	0.58	0.75	0.87	113.2	5.47	0.57	0.76	0.87	106.9	6.3	0.57	0.77	0.89	
	4680	130.4	4.02	0.6	0.78	0.89	123.3	4.71	0.59	0.8	0.91	116.8	5.47	0.61	0.8	0.92	110.5	6.31	0.6	0.82	0.93	
71°F	3120	126.8	4.03	0.37	0.51	0.65	120.3	4.71	0.35	0.51	0.65	114.2	5.46	0.34	0.51	0.66	108.2	6.3	0.33	0.5	0.66	
	3900	133.1	4.01	0.36	0.54	0.71	126.1	4.71	0.36	0.54	0.72	119.8	5.48	0.35	0.55	0.72	113.3	6.32	0.34	0.55	0.74	
	4680	137.7	3.99	0.38	0.58	0.75	130.3	4.71	0.37	0.58	0.76	123.7	5.48	0.36	0.58	0.79	116.9	6.33	0.35	0.58	0.79	

NOTE - Compressors operating at maximum capacity.

13 TON - LCM156U5M/V (THREE COMPRESSORS OPERATING)

Entering Wet Bulb Temperature	Total Air Volume	Outdoor Air Temperature Entering Outdoor Coil																			
		85°F					95°F					105°F					115°F				
		Total Cool Cap.	Comp. Motor Input	Sensible To Total Ratio (S/T)			Total Cool Cap.	Comp. Motor Input	Sensible To Total Ratio (S/T)			Total Cool Cap.	Comp. Motor Input	Sensible To Total Ratio (S/T)			Total Cool Cap.	Comp. Motor Input	Sensible To Total Ratio (S/T)		
				Dry Bulb					Dry Bulb					Dry Bulb					Dry Bulb		
		cfm	kBtuh	kW	75°F	80°F	85°F	kBtuh	kW	75°F	80°F	85°F	kBtuh	kW	75°F	80°F	85°F	kBtuh	kW	75°F	80°F
63°F	4160	155.7	7.78	0.71	0.82	0.93	146.9	8.92	0.71	0.83	0.94	139.2	10.25	0.71	0.84	0.96	130.4	11.74	0.73	0.86	0.98
	5200	165.5	7.78	0.75	0.87	0.98	156.4	8.93	0.76	0.89	0.99	148.4	10.27	0.77	0.9	1	138.8	11.72	0.78	0.92	1
	6240	173	7.77	0.79	0.92	1	163.6	8.94	0.8	0.94	1	154.4	10.26	0.81	0.96	1	144.8	11.73	0.83	0.98	1
67°F	4160	163.6	7.77	0.55	0.68	0.8	152.7	8.91	0.56	0.69	0.81	145.6	10.24	0.55	0.69	0.82	134.9	11.72	0.55	0.72	0.83
	5200	170.6	7.76	0.59	0.74	0.85	161.6	8.92	0.58	0.74	0.86	152.4	10.25	0.6	0.75	0.88	142.8	11.72	0.6	0.76	0.9
	6240	177.8	7.76	0.61	0.77	0.9	168.1	8.94	0.62	0.78	0.92	158.6	10.26	0.63	0.79	0.94	148.1	11.74	0.63	0.81	0.96
71°F	4160	173.4	7.76	0.41	0.54	0.66	164.2	8.93	0.4	0.53	0.68	153	10.24	0.4	0.56	0.69	143.2	11.72	0.4	0.56	0.69
	5200	180.3	7.75	0.43	0.58	0.72	170.5	8.93	0.43	0.59	0.73	162.3	10.27	0.42	0.58	0.73	151.6	11.75	0.41	0.59	0.75
	6240	186.4	7.73	0.43	0.61	0.76	178.1	8.95	0.44	0.62	0.77	166.4	10.27	0.43	0.63	0.79	155	11.75	0.43	0.63	0.8

NOTE - Compressors operating at maximum capacity.

COOLING RATINGS

NOTE – For Temperatures and Capacities not shown in tables, see bulletin – Cooling Unit Rating Table Correction Factor Data in Miscellaneous Engineering Data section.

15 TON - LCM180U5M/V (ONE COMPRESSOR OPERATING)

Entering Wet Bulb Temperature	Total Air Volume	Outdoor Air Temperature Entering Outdoor Coil																			
		65°F					75°F					85°F					95°F				
		Total Cool Cap.	Comp. Motor Input	Sensible To Total Ratio (S/T)			Total Cool Cap.	Comp. Motor Input	Sensible To Total Ratio (S/T)			Total Cool Cap.	Comp. Motor Input	Sensible To Total Ratio (S/T)			Total Cool Cap.	Comp. Motor Input	Sensible To Total Ratio (S/T)		
				Dry Bulb					Dry Bulb					Dry Bulb					Dry Bulb		
cfm	kBtuh	kW	75°F	80°F	85°F	kBtuh	kW	75°F	80°F	85°F	kBtuh	kW	75°F	80°F	85°F	kBtuh	kW	75°F	80°F	85°F	
63°F	1600	46.8	0.67	1	1	1	43.6	0.82	1	1	1	40.6	1.01	1	1	1	37.7	1.23	1	1	1
	2000	49.8	0.65	1	1	1	46.6	0.81	1	1	1	43.5	1	1	1	1	40.4	1.23	1	1	1
	2400	52.2	0.65	1	1	1	48.9	0.8	1	1	1	45.6	1	1	1	1	42.4	1.22	1	1	1
67°F	1600	49.5	0.66	1	1	1	46.1	0.81	1	1	1	42.8	1.01	1	1	1	39.4	1.23	1	1	1
	2000	51.6	0.65	1	1	1	48.1	0.8	1	1	1	44.7	1	1	1	1	41.2	1.22	1	1	1
	2400	53.2	0.64	1	1	1	49.6	0.8	1	1	1	46.1	1	1	1	1	42.6	1.22	1	1	1
71°F	1600	52.7	0.65	0.93	1	1	49.2	0.8	0.82	1	1	45.8	1	0.74	1	1	42.3	1.23	0.61	1	1
	2000	54.7	0.64	0.98	1	1	51.1	0.8	0.89	1	1	47.5	1	0.8	1	1	44	1.22	0.7	1	1
	2400	56.2	0.64	1	1	1	52.5	0.8	0.98	1	1	48.8	1	0.9	1	1	45.2	1.23	0.8	1	1

NOTE - Compressor operating at maximum capacity.

15 TON - LCM180U5M/V (TWO COMPRESSORS OPERATING)

Entering Wet Bulb Temperature	Total Air Volume	Outdoor Air Temperature Entering Outdoor Coil																			
		65°F					75°F					85°F					95°F				
		Total Cool Cap.	Comp. Motor Input	Sensible To Total Ratio (S/T)			Total Cool Cap.	Comp. Motor Input	Sensible To Total Ratio (S/T)			Total Cool Cap.	Comp. Motor Input	Sensible To Total Ratio (S/T)			Total Cool Cap.	Comp. Motor Input	Sensible To Total Ratio (S/T)		
				Dry Bulb					Dry Bulb					Dry Bulb					Dry Bulb		
cfm	kBtuh	kW	75°F	80°F	85°F	kBtuh	kW	75°F	80°F	85°F	kBtuh	kW	75°F	80°F	85°F	kBtuh	kW	75°F	80°F	85°F	
63°F	3600	120	3.88	0.79	0.9	0.97	113.1	4.52	0.78	0.91	0.97	105.7	5.22	0.79	0.91	0.98	99.1	6	0.79	0.92	0.99
	4500	127.8	3.84	0.85	0.93	0.99	120.8	4.49	0.84	0.94	0.99	113.2	5.2	0.84	0.95	1	105.7	5.99	0.86	0.96	1
	5400	134	3.81	0.88	0.96	1	126.3	4.46	0.87	0.97	1	118.5	5.18	0.88	0.97	1	110.9	5.98	0.89	0.98	1
67°F	3600	127	3.83	0.58	0.76	0.88	119.8	4.47	0.58	0.75	0.89	111.6	5.19	0.57	0.75	0.89	104.2	5.98	0.56	0.75	0.9
	4500	133.4	3.79	0.61	0.81	0.91	125.7	4.45	0.62	0.81	0.92	117.4	5.17	0.61	0.83	0.93	109.1	5.96	0.59	0.84	0.94
	5400	138	3.75	0.65	0.86	0.94	129.4	4.43	0.64	0.86	0.95	121.4	5.15	0.65	0.87	0.96	113.5	5.96	0.63	0.88	0.97
71°F	3600	134.9	3.77	0.38	0.55	0.72	127	4.44	0.36	0.56	0.71	118.9	5.15	0.35	0.55	0.71	111.6	5.96	0.32	0.54	0.71
	4500	141.6	3.73	0.39	0.59	0.78	133.4	4.4	0.37	0.58	0.78	124.9	5.14	0.37	0.59	0.79	116.8	5.95	0.35	0.59	0.79
	5400	146.5	3.69	0.42	0.62	0.82	137.9	4.38	0.4	0.63	0.84	129.1	5.13	0.39	0.62	0.85	120.8	5.94	0.37	0.64	0.85

NOTE - Compressors operating at maximum capacity.

15 TON - LCM180U5M/V (THREE COMPRESSORS OPERATING)

Entering Wet Bulb Temperature	Total Air Volume	Outdoor Air Temperature Entering Outdoor Coil																			
		85°F					95°F					105°F					115°F				
		Total Cool Cap.	Comp. Motor Input	Sensible To Total Ratio (S/T)			Total Cool Cap.	Comp. Motor Input	Sensible To Total Ratio (S/T)			Total Cool Cap.	Comp. Motor Input	Sensible To Total Ratio (S/T)			Total Cool Cap.	Comp. Motor Input	Sensible To Total Ratio (S/T)		
				Dry Bulb					Dry Bulb					Dry Bulb					Dry Bulb		
cfm	kBtuh	kW	75°F	80°F	85°F	kBtuh	kW	75°F	80°F	85°F	kBtuh	kW	75°F	80°F	85°F	kBtuh	kW	75°F	80°F	85°F	
63°F	4800	175.4	9.5	0.7	0.82	0.92	164.2	10.83	0.7	0.82	0.93	152.8	12.32	0.71	0.83	0.95	141.1	14.03	0.71	0.84	0.96
	6000	187.2	9.53	0.75	0.86	0.97	175.9	10.86	0.75	0.88	0.98	163.5	12.37	0.76	0.89	0.99	150.9	14.08	0.76	0.91	1
	7200	196.5	9.55	0.78	0.91	1	184.6	10.89	0.79	0.93	1	171.5	12.4	0.8	0.95	1	158.3	14.11	0.81	0.97	1
67°F	4800	183.9	9.52	0.55	0.68	0.79	172.4	10.85	0.54	0.69	0.8	160.5	12.35	0.53	0.7	0.81	147	14.04	0.53	0.69	0.82
	6000	193.5	9.53	0.57	0.72	0.84	181.8	10.87	0.58	0.73	0.85	169.4	12.38	0.57	0.73	0.87	156.5	14.09	0.56	0.74	0.88
	7200	202.3	9.55	0.62	0.77	0.89	189.8	10.9	0.6	0.77	0.9	176.8	12.42	0.62	0.78	0.92	163.2	14.14	0.6	0.79	0.94
71°F	4800	196.5	9.54	0.41	0.53	0.67	184.6	10.89	0.38	0.54	0.67	171.6	12.39	0.38	0.53	0.67	158.1	14.1	0.35	0.52	0.68
	6000	206.8	9.56	0.41	0.58	0.71	193.8	10.92	0.41	0.57	0.72	180.3	12.44	0.39	0.56	0.72	164.6	14.12	0.37	0.58	0.73
	7200	212.5	9.56	0.44	0.61	0.75	199	10.92	0.42	0.6	0.76	187.1	12.47	0.41	0.61	0.77	171.6	14.18	0.41	0.61	0.78

NOTE - Compressors operating at maximum capacity.

COOLING RATINGS

NOTE – For Temperatures and Capacities not shown in tables, see bulletin – Cooling Unit Rating Table Correction Factor Data in Miscellaneous Engineering Data section.

17.5 TON - LCM210U5M/V (ONE COMPRESSOR OPERATING)

Entering Wet Bulb Temperature	Total Air Volume	Outdoor Air Temperature Entering Outdoor Coil																			
		65°F					75°F					85°F					95°F				
		Total Cool Cap.	Comp. Motor Input	Sensible To Total Ratio (S/T)			Total Cool Cap.	Comp. Motor Input	Sensible To Total Ratio (S/T)			Total Cool Cap.	Comp. Motor Input	Sensible To Total Ratio (S/T)			Total Cool Cap.	Comp. Motor Input	Sensible To Total Ratio (S/T)		
				Dry Bulb					Dry Bulb					Dry Bulb					Dry Bulb		
cfm	kBtuh	kW	75°F	80°F	85°F	kBtuh	kW	75°F	80°F	85°F	kBtuh	kW	75°F	80°F	85°F	kBtuh	kW	75°F	80°F	85°F	
63°F	1600	48.2	1.57	0.82	0.95	1	44.9	1.86	0.82	0.96	1	41.7	2.19	0.82	0.96	1	38.2	2.55	0.82	0.97	1
	2000	51	1.57	0.88	0.98	1	47.6	1.86	0.88	0.98	1	44	2.19	0.88	0.99	1	40.9	2.56	0.89	0.99	1
	2400	53.2	1.57	0.91	0.99	1	49.8	1.86	0.91	1	1	46	2.2	0.92	1	1	42.8	2.57	0.93	1	1
67°F	1600	51.1	1.57	0.53	0.78	0.94	47.8	1.86	0.51	0.78	0.94	44.5	2.19	0.49	0.77	0.94	41.1	2.56	0.46	0.77	0.95
	2000	53.9	1.57	0.56	0.85	0.97	50.3	1.86	0.55	0.85	0.97	46.6	2.2	0.54	0.85	0.98	43.3	2.57	0.52	0.87	0.98
	2400	55.9	1.57	0.6	0.89	0.99	52.3	1.87	0.59	0.89	0.99	48.4	2.21	0.58	0.9	1	44.8	2.58	0.57	0.91	1
71°F	1600	54.7	1.57	0.23	0.49	0.73	51.3	1.86	0.2	0.48	0.73	47.9	2.2	0.16	0.46	0.73	44.4	2.57	0.11	0.44	0.73
	2000	57.3	1.57	0.24	0.53	0.8	53.8	1.87	0.2	0.52	0.8	49.9	2.21	0.17	0.51	0.81	46.5	2.58	0.13	0.5	0.82
	2400	59.3	1.57	0.24	0.57	0.86	55.3	1.87	0.21	0.57	0.87	51.6	2.21	0.18	0.56	0.88	47.8	2.59	0.15	0.55	0.89

NOTE - Compressor operating at maximum capacity.

17.5 TON - LCM210U5M/V (TWO COMPRESSORS OPERATING)

Entering Wet Bulb Temperature	Total Air Volume	Outdoor Air Temperature Entering Outdoor Coil																			
		65°F					75°F					85°F					95°F				
		Total Cool Cap.	Comp. Motor Input	Sensible To Total Ratio (S/T)			Total Cool Cap.	Comp. Motor Input	Sensible To Total Ratio (S/T)			Total Cool Cap.	Comp. Motor Input	Sensible To Total Ratio (S/T)			Total Cool Cap.	Comp. Motor Input	Sensible To Total Ratio (S/T)		
				Dry Bulb					Dry Bulb					Dry Bulb					Dry Bulb		
cfm	kBtuh	kW	75°F	80°F	85°F	kBtuh	kW	75°F	80°F	85°F	kBtuh	kW	75°F	80°F	85°F	kBtuh	kW	75°F	80°F	85°F	
63°F	2800	101	3.86	0.72	0.85	0.97	94.6	4.47	0.72	0.86	0.98	87.8	5.16	0.72	0.87	0.99	81	5.94	0.73	0.88	1
	3500	107.9	3.88	0.77	0.91	1	100.7	4.49	0.77	0.93	1	94	5.2	0.78	0.94	1	86.7	5.98	0.78	0.96	1
	4200	113.3	3.9	0.81	0.97	1	106	4.52	0.82	0.98	1	98.7	5.23	0.83	0.99	1	91.7	6.02	0.84	1	1
67°F	2800	107.6	3.88	0.57	0.71	0.83	100.5	4.49	0.57	0.71	0.83	93.2	5.19	0.56	0.71	0.84	86.5	5.98	0.55	0.71	0.86
	3500	114	3.9	0.61	0.75	0.89	106.8	4.52	0.6	0.76	0.9	99.2	5.23	0.6	0.76	0.92	91.4	6.01	0.59	0.77	0.93
	4200	118.9	3.92	0.64	0.8	0.94	111	4.54	0.64	0.81	0.96	103.7	5.26	0.63	0.81	0.97	95.6	6.04	0.63	0.83	0.99
71°F	2800	114.2	3.9	0.43	0.57	0.69	106.9	4.52	0.41	0.56	0.69	99.7	5.22	0.4	0.55	0.69	92.1	6.01	0.38	0.55	0.7
	3500	121.2	3.92	0.45	0.6	0.74	113.3	4.55	0.44	0.6	0.74	105.4	5.27	0.42	0.6	0.75	97.7	6.06	0.41	0.59	0.76
	4200	125.9	3.94	0.46	0.63	0.78	117.9	4.58	0.46	0.63	0.79	109.7	5.3	0.44	0.63	0.8	101.7	6.1	0.42	0.63	0.82

NOTE - Compressors operating at maximum capacity.

17.5 TON - LCM210U5M/V (THREE COMPRESSORS OPERATING)

Entering Wet Bulb Temperature	Total Air Volume	Outdoor Air Temperature Entering Outdoor Coil																			
		85°F					95°F					105°F					115°F				
		Total Cool Cap.	Comp. Motor Input	Sensible To Total Ratio (S/T)			Total Cool Cap.	Comp. Motor Input	Sensible To Total Ratio (S/T)			Total Cool Cap.	Comp. Motor Input	Sensible To Total Ratio (S/T)			Total Cool Cap.	Comp. Motor Input	Sensible To Total Ratio (S/T)		
				Dry Bulb					Dry Bulb					Dry Bulb					Dry Bulb		
cfm	kBtuh	kW	75°F	80°F	85°F	kBtuh	kW	75°F	80°F	85°F	kBtuh	kW	75°F	80°F	85°F	kBtuh	kW	75°F	80°F	85°F	
63°F	4200	142.6	8.85	0.8	0.96	1	131.6	10.17	0.78	0.96	1	120.8	11.64	0.8	0.96	1	108.8	13.29	0.8	0.97	1
	5250	152.3	8.93	0.88	0.98	1	141.6	10.26	0.89	0.98	1	129.6	11.74	0.9	0.99	1	117.6	13.39	0.89	0.99	1
	6300	160.2	9.01	0.92	0.99	1	148.9	10.35	0.93	1	1	136.6	11.82	0.94	1	1	124.4	13.48	0.95	1	1
67°F	4200	152.9	8.93	0.53	0.76	0.94	141.5	10.25	0.51	0.76	0.94	129.2	11.71	0.46	0.75	0.95	116.9	13.37	0.43	0.75	0.95
	5250	161.1	9.01	0.58	0.84	0.97	148.6	10.33	0.55	0.87	0.97	136	11.8	0.53	0.87	0.98	123.1	13.45	0.5	0.88	0.98
	6300	166.3	9.06	0.61	0.91	0.99	154.2	10.4	0.6	0.92	0.99	141.6	11.87	0.57	0.93	0.99	128.2	13.52	0.55	0.93	1
71°F	4200	165	9.03	0.27	0.5	0.71	152.6	10.35	0.23	0.48	0.71	140.2	11.83	0.19	0.46	0.7	127.4	13.48	0.12	0.42	0.71
	5250	172.3	9.11	0.27	0.53	0.8	160	10.45	0.24	0.52	0.81	147.2	11.92	0.2	0.5	0.83	133.5	13.57	0.15	0.48	0.86
	6300	177.9	9.18	0.3	0.59	0.89	164.7	10.51	0.26	0.57	0.9	151.5	11.99	0.22	0.58	0.91	137.8	13.64	0.17	0.57	0.93

NOTE - Compressors operating at maximum capacity.

17.5 TON - LCM210U5M/V (FOUR COMPRESSORS OPERATING)

Entering Wet Bulb Temperature	Total Air Volume	Outdoor Air Temperature Entering Outdoor Coil																			
		85°F					95°F					105°F					115°F				
		Total Cool Cap.	Comp. Motor Input	Sensible To Total Ratio (S/T)			Total Cool Cap.	Comp. Motor Input	Sensible To Total Ratio (S/T)			Total Cool Cap.	Comp. Motor Input	Sensible To Total Ratio (S/T)			Total Cool Cap.	Comp. Motor Input	Sensible To Total Ratio (S/T)		
				Dry Bulb					Dry Bulb					Dry Bulb					Dry Bulb		
cfm	kBtuh	kW	75°F	80°F	85°F	kBtuh	kW	75°F	80°F	85°F	kBtuh	kW	75°F	80°F	85°F	kBtuh	kW	75°F	80°F	85°F	
63°F	5600	205.8	11.2	0.69	0.83	0.92	191.4	12.86	0.68	0.83	0.93	176.5	14.73	0.69	0.84	0.95	160.2	16.85	0.69	0.85	0.96
	7000	221.1	11.25	0.75	0.88	0.98	206	12.92	0.76	0.89	0.99	190.5	14.8	0.76	0.9	1	173.2	16.92	0.78	0.91	1
	8400	233.1	11.29	0.8	0.92	1	217	12.97	0.81	0.94	1	200.8	14.86	0.82	0.95	1	183	16.98	0.83	0.97	1
67°F	5600	219.1	11.25	0.52	0.66	0.81	203.5	12.91	0.51	0.67	0.81	187.5	14.78	0.5	0.67	0.82	170.2	16.89	0.48	0.67	0.83
	7000	231.5	11.3	0.55	0.74	0.86	215.2	12.97	0.54	0.73	0.87	198.3	14.85	0.55	0.75	0.88	180.1	16.95	0.53	0.77	0.89
	8400	241	11.34	0.59	0.8	0.9	224.5	13.02	0.58	0.79	0.92	207.2	14.9	0.58	0.8	0.93	189.4	17.02	0.58	0.81	0.95
71°F	5600	235.4	11.3	0.37	0.52	0.64	218.9	12.98	0.35	0.49	0.66	202.8	14.86	0.33	0.5	0.66	184.2	16.97	0.29	0.47	0.66
	7000	247.2	11.36	0.39	0.56	0.7	230.4	13.04	0.37	0.54	0.72	212.6	14.93	0.36	0.54	0.73	193.8	17.05	0.32	0.53	0.74
	8400	256.6	11.4	0.41	0.58	0.77	238.5	13.09	0.39	0.58	0.78	219.9	14.98	0.36	0.59	0.79	200.8	17.11	0.32	0.59	0.8

NOTE - Compressors operating at maximum capacity.

COOLING RATINGS

NOTE – For Temperatures and Capacities not shown in tables, see bulletin – Cooling Unit Rating Table Correction Factor Data in Miscellaneous Engineering Data section.

20 TON - LCM240U5M/V (ONE COMPRESSOR OPERATING)

Entering Wet Bulb Temperature	Total Air Volume	Outdoor Air Temperature Entering Outdoor Coil																			
		65°F					75°F					85°F					95°F				
		Total Cool Cap.	Comp. Motor Input	Sensible To Total Ratio (S/T)			Total Cool Cap.	Comp. Motor Input	Sensible To Total Ratio (S/T)			Total Cool Cap.	Comp. Motor Input	Sensible To Total Ratio (S/T)			Total Cool Cap.	Comp. Motor Input	Sensible To Total Ratio (S/T)		
				Dry Bulb					Dry Bulb					Dry Bulb					Dry Bulb		
cfm	kBtuh	kW	75°F	80°F	85°F	kBtuh	kW	75°F	80°F	85°F	kBtuh	kW	75°F	80°F	85°F	kBtuh	kW	75°F	80°F	85°F	
63°F	1600	50	1.85	0.6	0.76	0.91	47.3	2.16	0.59	0.77	0.92	44.9	2.5	0.6	0.79	0.94	42.3	2.87	0.6	0.8	0.96
	2000	53	1.85	0.63	0.82	0.97	50.2	2.17	0.63	0.83	0.98	47.6	2.51	0.64	0.85	1	44.5	2.89	0.65	0.87	1
	2400	55.4	1.85	0.67	0.87	1	52.5	2.17	0.68	0.89	1	49.6	2.52	0.69	0.91	1	46.7	2.9	0.7	0.93	1
67°F	1600	52.7	1.85	0.39	0.55	0.72	50	2.16	0.38	0.55	0.73	47.4	2.51	0.37	0.55	0.74	44.5	2.88	0.36	0.56	0.75
	2000	55.6	1.85	0.4	0.59	0.78	52.7	2.17	0.4	0.6	0.79	49.9	2.52	0.39	0.6	0.81	47.1	2.9	0.39	0.61	0.82
	2400	57.8	1.85	0.42	0.63	0.83	54.8	2.18	0.42	0.64	0.85	51.6	2.53	0.42	0.66	0.87	48.8	2.92	0.41	0.66	0.89
71°F	1600	55.9	1.85	0.18	0.36	0.52	53.1	2.17	0.16	0.35	0.51	50.1	2.52	0.14	0.34	0.51	47.5	2.9	0.12	0.33	0.52
	2000	58.8	1.85	0.17	0.37	0.55	55.5	2.18	0.16	0.37	0.56	52.6	2.54	0.14	0.36	0.57	49.8	2.92	0.12	0.36	0.57
	2400	60.9	1.85	0.17	0.39	0.59	57.4	2.18	0.16	0.39	0.6	54.7	2.55	0.14	0.39	0.62	51.6	2.94	0.13	0.39	0.63

NOTE - Compressor operating at maximum capacity.

20 TON - LCM240U5M/V (TWO COMPRESSORS OPERATING)

Entering Wet Bulb Temperature	Total Air Volume	Outdoor Air Temperature Entering Outdoor Coil																			
		65°F					75°F					85°F					95°F				
		Total Cool Cap.	Comp. Motor Input	Sensible To Total Ratio (S/T)			Total Cool Cap.	Comp. Motor Input	Sensible To Total Ratio (S/T)			Total Cool Cap.	Comp. Motor Input	Sensible To Total Ratio (S/T)			Total Cool Cap.	Comp. Motor Input	Sensible To Total Ratio (S/T)		
				Dry Bulb					Dry Bulb					Dry Bulb					Dry Bulb		
cfm	kBtuh	kW	75°F	80°F	85°F	kBtuh	kW	75°F	80°F	85°F	kBtuh	kW	75°F	80°F	85°F	kBtuh	kW	75°F	80°F	85°F	
63°F	3200	108.7	4.1	0.73	0.85	0.96	103	4.74	0.73	0.86	0.97	97.2	5.43	0.74	0.87	0.98	91	6.19	0.74	0.88	0.99
	4000	115.8	4.11	0.77	0.9	1	109.6	4.74	0.78	0.91	1	102.7	5.44	0.78	0.93	1	96.7	6.21	0.79	0.95	1
	4800	120.9	4.11	0.8	0.95	1	114.6	4.75	0.81	0.96	1	108.2	5.45	0.83	0.98	1	101.6	6.22	0.84	0.99	1
67°F	3200	114.5	4.11	0.58	0.71	0.82	108.4	4.74	0.58	0.71	0.83	102	5.44	0.57	0.72	0.84	95.4	6.2	0.57	0.72	0.86
	4000	121.2	4.11	0.6	0.75	0.88	114.3	4.75	0.6	0.76	0.89	107.7	5.45	0.61	0.77	0.9	101.1	6.22	0.61	0.78	0.93
	4800	125.7	4.1	0.63	0.79	0.93	119.2	4.75	0.63	0.8	0.94	112.1	5.46	0.64	0.81	0.96	105.2	6.23	0.64	0.82	0.97
71°F	3200	121.2	4.1	0.43	0.56	0.69	114.5	4.75	0.43	0.56	0.7	108	5.45	0.42	0.56	0.7	101.6	6.22	0.41	0.56	0.7
	4000	127.9	4.1	0.44	0.6	0.73	121.1	4.76	0.44	0.59	0.74	113.7	5.46	0.43	0.6	0.75	106.7	6.23	0.43	0.6	0.76
	4800	133	4.1	0.46	0.63	0.78	125.8	4.76	0.45	0.63	0.79	117.9	5.47	0.45	0.63	0.8	110.6	6.25	0.44	0.64	0.81

NOTE - Compressors operating at maximum capacity.

20 TON - LCM240U5M/V (THREE COMPRESSORS OPERATING)

Entering Wet Bulb Temperature	Total Air Volume	Outdoor Air Temperature Entering Outdoor Coil																			
		85°F					95°F					105°F					115°F				
		Total Cool Cap.	Comp. Motor Input	Sensible To Total Ratio (S/T)			Total Cool Cap.	Comp. Motor Input	Sensible To Total Ratio (S/T)			Total Cool Cap.	Comp. Motor Input	Sensible To Total Ratio (S/T)			Total Cool Cap.	Comp. Motor Input	Sensible To Total Ratio (S/T)		
				Dry Bulb					Dry Bulb					Dry Bulb					Dry Bulb		
cfm	kBtuh	kW	75°F	80°F	85°F	kBtuh	kW	75°F	80°F	85°F	kBtuh	kW	75°F	80°F	85°F	kBtuh	kW	75°F	80°F	85°F	
63°F	4800	161	8.99	0.77	0.92	0.98	151.5	10.23	0.77	0.93	0.98	140.7	11.58	0.77	0.94	0.99	130.8	13.12	0.78	0.95	0.99
	6000	170.1	9.02	0.83	0.96	0.99	160.2	10.26	0.83	0.96	0.99	150.5	11.62	0.86	0.97	1	139.9	13.16	0.87	0.97	1
	7200	178.3	9.04	0.88	0.97	1	168.3	10.28	0.9	0.98	1	157.9	11.65	0.9	0.98	1	146.8	13.18	0.91	0.99	1
67°F	4800	170.2	9.02	0.5	0.71	0.9	160.1	10.26	0.49	0.71	0.91	149.8	11.62	0.45	0.71	0.92	138.8	13.15	0.44	0.74	0.93
	6000	178.8	9.04	0.51	0.79	0.94	168.8	10.29	0.52	0.82	0.95	157.4	11.65	0.51	0.83	0.95	145.7	13.18	0.49	0.84	0.96
	7200	185.5	9.06	0.56	0.85	0.96	174.3	10.31	0.54	0.88	0.97	163.1	11.68	0.54	0.88	0.97	150.8	13.2	0.56	0.9	0.98
71°F	4800	181.9	9.05	0.25	0.47	0.67	170.1	10.29	0.23	0.43	0.66	159.6	11.66	0.22	0.43	0.66	148.2	13.19	0.17	0.41	0.67
	6000	189.9	9.08	0.26	0.48	0.75	178.8	10.32	0.25	0.47	0.75	167.5	11.69	0.21	0.46	0.79	155	13.22	0.19	0.46	0.82
	7200	196.6	9.09	0.27	0.52	0.84	184.6	10.34	0.26	0.53	0.84	172.5	11.71	0.22	0.54	0.86	160.3	13.24	0.19	0.53	0.87

NOTE - Compressors operating at maximum capacity.

20 TON - LCM240U5M/V (FOUR COMPRESSORS OPERATING)

Entering Wet Bulb Temperature	Total Air Volume	Outdoor Air Temperature Entering Outdoor Coil																			
		85°F					95°F					105°F					115°F				
		Total Cool Cap.	Comp. Motor Input	Sensible To Total Ratio (S/T)			Total Cool Cap.	Comp. Motor Input	Sensible To Total Ratio (S/T)			Total Cool Cap.	Comp. Motor Input	Sensible To Total Ratio (S/T)			Total Cool Cap.	Comp. Motor Input	Sensible To Total Ratio (S/T)		
				Dry Bulb					Dry Bulb					Dry Bulb					Dry Bulb		
cfm	kBtuh	kW	75°F	80°F	85°F	kBtuh	kW	75°F	80°F	85°F	kBtuh	kW	75°F	80°F	85°F	kBtuh	kW	75°F	80°F	85°F	
63°F	6400	236.5	13.65	0.68	0.84	0.92	224	15.45	0.68	0.83	0.93	209.8	17.44	0.7	0.85	0.94	195.1	19.71	0.71	0.86	0.96
	8000	252.4	13.69	0.74	0.87	0.97	238.6	15.49	0.74	0.88	0.98	223.8	17.48	0.77	0.9	0.99	209	19.74	0.79	0.91	1
	9600	265.5	13.71	0.8	0.91	1	250.1	15.52	0.8	0.93	1	234.9	17.51	0.82	0.94	1	219.1	19.77	0.83	0.96	1
67°F	6400	251	13.68	0.51	0.65	0.81	236.6	15.48	0.51	0.67	0.81	221	17.46	0.51	0.68	0.82	205.3	19.73	0.5	0.69	0.83
	8000	264.3	13.71	0.53	0.72	0.85	249	15.51	0.55	0.72	0.86	232.9	17.5	0.54	0.75	0.87	216.1	19.76	0.54	0.76	0.89
	9600	274	13.73	0.57	0.77	0.89	257.5	15.53	0.58	0.79	0.91	241.3	17.52	0.58	0.81	0.92	224.7	19.78	0.58	0.83	0.94
71°F	6400	266.4	13.71	0.37	0.49	0.63	251.3	15.51	0.35	0.49	0.63	235.3	17.5	0.34	0.5	0.65	219.3	19.76	0.33	0.5	0.66
	8000	279.1	13.74	0.39	0.53	0.69	263.3	15.54	0.38	0.53	0.71	247.2	17.53	0.36	0.52	0.71	230	19.79	0.33	0.54	0.74
	9600	288.8	13.76	0.39	0.58	0.76	272	15.56	0.36	0.58	0.76	255.2	17.55	0.37	0.57	0.78	237.5	19.81	0.36	0.59	0.8

NOTE - Compressors operating at maximum capacity.

COOLING RATINGS

NOTE – For Temperatures and Capacities not shown in tables, see bulletin – Cooling Unit Rating Table Correction Factor Data in Miscellaneous Engineering Data section.

25 TON - LCM300U5M/V (ONE COMPRESSOR OPERATING)

Entering Wet Bulb Temperature	Total Air Volume	Outdoor Air Temperature Entering Outdoor Coil																			
		65°F					75°F					85°F					95°F				
		Total Cool Cap.	Comp. Motor Input	Sensible To Total Ratio (S/T)			Total Cool Cap.	Comp. Motor Input	Sensible To Total Ratio (S/T)			Total Cool Cap.	Comp. Motor Input	Sensible To Total Ratio (S/T)			Total Cool Cap.	Comp. Motor Input	Sensible To Total Ratio (S/T)		
				Dry Bulb					Dry Bulb					Dry Bulb					Dry Bulb		
cfm	kBtuh	kW	75°F	80°F	85°F	kBtuh	kW	75°F	80°F	85°F	kBtuh	kW	75°F	80°F	85°F	kBtuh	kW	75°F	80°F	85°F	
63°F	2000	55.9	2.02	0.86	1	1	53.8	2.36	0.88	1	1	51.8	2.73	0.9	1	1	49.5	3.12	0.92	1	1
	2500	58.7	2.02	0.93	1	1	56.6	2.37	0.95	1	1	54.4	2.74	0.96	1	1	51.9	3.14	0.97	1	1
	3000	60.9	2.02	0.97	1	1	58.3	2.37	0.97	1	1	56.1	2.75	0.98	1	1	54.2	3.15	0.99	1	1
67°F	2000	58.5	2.02	0.56	0.81	0.98	56.3	2.37	0.56	0.83	0.99	53.9	2.74	0.57	0.85	0.99	52	3.14	0.58	0.86	1
	2500	61.2	2.02	0.59	0.88	1	58.5	2.37	0.6	0.91	1	56.2	2.75	0.62	0.93	1	54.1	3.15	0.63	0.95	1
	3000	63.1	2.01	0.63	0.95	1	60.3	2.37	0.65	0.96	1	58.1	2.76	0.66	0.97	1	55.3	3.16	0.68	0.98	1
71°F	2000	61.2	2.02	0.23	0.51	0.76	58.7	2.37	0.23	0.52	0.77	56.4	2.75	0.23	0.53	0.79	54.4	3.15	0.23	0.54	0.81
	2500	63.8	2.01	0.24	0.55	0.83	61.2	2.37	0.24	0.57	0.85	59	2.76	0.24	0.58	0.87	56.3	3.17	0.24	0.59	0.9
	3000	65.9	2.01	0.25	0.6	0.9	63.3	2.38	0.25	0.61	0.93	60.5	2.77	0.25	0.63	0.95	57.9	3.18	0.26	0.65	0.96

NOTE - Compressor operating at maximum capacity.

25 TON - LCM300U5M/V (TWO COMPRESSORS OPERATING)

Entering Wet Bulb Temperature	Total Air Volume	Outdoor Air Temperature Entering Outdoor Coil																			
		65°F					75°F					85°F					95°F				
		Total Cool Cap.	Comp. Motor Input	Sensible To Total Ratio (S/T)			Total Cool Cap.	Comp. Motor Input	Sensible To Total Ratio (S/T)			Total Cool Cap.	Comp. Motor Input	Sensible To Total Ratio (S/T)			Total Cool Cap.	Comp. Motor Input	Sensible To Total Ratio (S/T)		
				Dry Bulb					Dry Bulb					Dry Bulb					Dry Bulb		
cfm	kBtuh	kW	75°F	80°F	85°F	kBtuh	kW	75°F	80°F	85°F	kBtuh	kW	75°F	80°F	85°F	kBtuh	kW	75°F	80°F	85°F	
63°F	4000	128.2	5.34	0.75	0.89	0.99	123.1	6.13	0.76	0.9	1	117.7	7.02	0.77	0.92	1	112.7	8.02	0.79	0.94	1
	5000	134.2	5.36	0.8	0.95	1	129.3	6.17	0.81	0.96	1	123.7	7.07	0.83	0.98	1	118.7	8.08	0.84	0.99	1
	6000	139.6	5.39	0.85	0.99	1	134.3	6.21	0.86	1	1	128.7	7.11	0.88	1	1	123.5	8.13	0.9	1	1
67°F	4000	134.7	5.37	0.59	0.73	0.86	129.8	6.18	0.6	0.74	0.87	123.6	7.07	0.6	0.75	0.89	118.7	8.08	0.61	0.77	0.91
	5000	140.8	5.4	0.62	0.78	0.93	135.2	6.22	0.63	0.79	0.94	128.9	7.12	0.64	0.81	0.96	123.2	8.14	0.65	0.83	0.98
	6000	145.3	5.43	0.66	0.83	0.97	139.1	6.26	0.67	0.85	0.99	133.1	7.17	0.68	0.86	0.99	126.5	8.17	0.69	0.89	1
71°F	4000	140.8	5.39	0.45	0.58	0.71	135.8	6.21	0.45	0.59	0.72	129.6	7.12	0.45	0.59	0.73	124.2	8.14	0.45	0.6	0.75
	5000	148	5.44	0.46	0.62	0.76	141.8	6.27	0.46	0.63	0.78	135.8	7.19	0.46	0.63	0.79	129.3	8.2	0.47	0.65	0.81
	6000	152.7	5.47	0.47	0.65	0.81	145.9	6.31	0.48	0.66	0.83	139.7	7.23	0.48	0.67	0.85	133.5	8.26	0.48	0.68	0.87

NOTE - Compressors operating at maximum capacity.

25 TON - LCM300U5M/V (THREE COMPRESSORS OPERATING)

Entering Wet Bulb Temperature	Total Air Volume	Outdoor Air Temperature Entering Outdoor Coil																			
		85°F					95°F					105°F					115°F				
		Total Cool Cap.	Comp. Motor Input	Sensible To Total Ratio (S/T)			Total Cool Cap.	Comp. Motor Input	Sensible To Total Ratio (S/T)			Total Cool Cap.	Comp. Motor Input	Sensible To Total Ratio (S/T)			Total Cool Cap.	Comp. Motor Input	Sensible To Total Ratio (S/T)		
				Dry Bulb					Dry Bulb					Dry Bulb					Dry Bulb		
cfm	kBtuh	kW	75°F	80°F	85°F	kBtuh	kW	75°F	80°F	85°F	kBtuh	kW	75°F	80°F	85°F	kBtuh	kW	75°F	80°F	85°F	
63°F	5600	192.9	11.98	0.78	0.9	0.96	184.8	13.65	0.8	0.91	0.97	176.7	15.55	0.82	0.92	0.97	167.3	17.68	0.83	0.93	0.98
	7000	203.5	12.1	0.83	0.94	0.98	194.4	13.78	0.85	0.94	0.99	185.4	15.68	0.85	0.95	0.99	175.7	17.83	0.87	0.96	1
	8400	211.1	12.2	0.87	0.96	1	201.9	13.9	0.88	0.96	1	192.4	15.79	0.9	0.97	1	182.9	17.94	0.91	0.98	1
67°F	5600	201.7	12.09	0.54	0.73	0.87	193	13.78	0.54	0.74	0.89	183.2	15.66	0.55	0.77	0.9	173.5	17.81	0.57	0.78	0.91
	7000	210.1	12.2	0.57	0.81	0.92	200.6	13.89	0.58	0.82	0.93	190.9	15.79	0.59	0.83	0.94	180.2	17.93	0.61	0.86	0.95
	8400	216.1	12.27	0.63	0.85	0.94	207.2	13.99	0.64	0.87	0.95	196.8	15.89	0.66	0.88	0.96	186.5	18.04	0.67	0.9	0.97
71°F	5600	212.9	12.22	0.33	0.5	0.68	204	13.93	0.33	0.51	0.7	193.8	15.83	0.31	0.52	0.72	183.4	17.99	0.33	0.54	0.75
	7000	221.4	12.34	0.33	0.55	0.75	211.6	14.06	0.34	0.56	0.77	201	15.96	0.33	0.58	0.8	189.5	18.11	0.34	0.6	0.82
	8400	228.2	12.44	0.35	0.6	0.82	218	14.17	0.35	0.61	0.84	205.9	16.05	0.36	0.63	0.87	194.7	18.22	0.37	0.65	0.88

NOTE - Compressors operating at maximum capacity.

25 TON - LCM300U5M/V (FOUR COMPRESSORS OPERATING)

Entering Wet Bulb Temperature	Total Air Volume	Outdoor Air Temperature Entering Outdoor Coil																			
		85°F					95°F					105°F					115°F				
		Total Cool Cap.	Comp. Motor Input	Sensible To Total Ratio (S/T)			Total Cool Cap.	Comp. Motor Input	Sensible To Total Ratio (S/T)			Total Cool Cap.	Comp. Motor Input	Sensible To Total Ratio (S/T)			Total Cool Cap.	Comp. Motor Input	Sensible To Total Ratio (S/T)		
				Dry Bulb					Dry Bulb					Dry Bulb					Dry Bulb		
cfm	kBtuh	kW	75°F	80°F	85°F	kBtuh	kW	75°F	80°F	85°F	kBtuh	kW	75°F	80°F	85°F	kBtuh	kW	75°F	80°F	85°F	
63°F	7000	270.7	17.35	0.69	0.82	0.91	260.5	19.68	0.69	0.83	0.92	248.6	22.28	0.7	0.84	0.93	235.8	25.23	0.72	0.85	0.95
	8500	284.2	17.48	0.72	0.85	0.95	272.3	19.82	0.74	0.87	0.97	259.9	22.43	0.75	0.88	0.98	246.6	25.4	0.77	0.9	0.99
	10000	294.2	17.58	0.76	0.89	0.99	282.1	19.94	0.78	0.91	1	269.5	22.57	0.8	0.92	1	255.8	25.55	0.82	0.94	1
67°F	7000	282.7	17.47	0.54	0.66	0.79	270.1	19.8	0.53	0.66	0.8	260.3	22.45	0.54	0.69	0.81	246	25.41	0.55	0.71	0.83
	8500	296.4	17.63	0.56	0.71	0.83	283.6	19.98	0.56	0.72	0.84	270.7	22.61	0.56	0.73	0.86	255.5	25.57	0.57	0.76	0.87
	10000	305.6	17.72	0.58	0.75	0.87	292.1	20.09	0.59	0.77	0.88	277.8	22.72	0.59	0.78	0.9	263.9	25.71	0.6	0.79	0.92
71°F	7000	302.1	17.68	0.4	0.52	0.64	289.8	20.05	0.4	0.52	0.65	275.7	22.68	0.4	0.53	0.65	261.7	25.67	0.39	0.53	0.67
	8500	314.3	17.81	0.4	0.54	0.68	300.3	20.19	0.4	0.55	0.69	286	22.84	0.4	0.56	0.71	267.4	25.76	0.41	0.57	0.73
	10000	322.7	17.89	0.41	0.57	0.72	305.4	20.25	0.42	0.58	0.74	293.5	22.96	0.41	0.6	0.76	276.8	25.95	0.42	0.61	0.78

NOTE - Compressors operating at maximum capacity.

HUMIDITROL™ + DEHUMIDIFICATION SYSTEM RATINGS

13 TON - HIGH EFFICIENCY LCM156U5M WITH HUMIDITROL® (COMPRESSOR 1-2 IN REHEAT)

Entering Wet Bulb Temperature	Total Air Volume	Outdoor Air Temperature Entering Outdoor Coil																			
		65°F					75°F					85°F					95°F				
		Total Cool Cap.	Comp. Motor Input	Sensible To Total Ratio (S/T)			Total Cool Cap.	Comp. Motor Input	Sensible To Total Ratio (S/T)			Total Cool Cap.	Comp. Motor Input	Sensible To Total Ratio (S/T)			Total Cool Cap.	Comp. Motor Input	Sensible To Total Ratio (S/T)		
				Dry Bulb					Dry Bulb					Dry Bulb					Dry Bulb		
cfm	kBtuh	kW	75°F	80°F	85°F	kBtuh	kW	75°F	80°F	85°F	kBtuh	kW	75°F	80°F	85°F	kBtuh	kW	75°F	80°F	85°F	
63°F	1788	52.1	3.74	0.44	0.58	0.72	39.8	4.26	0.33	0.54	0.71	29.0	4.81	0.15	0.39	0.67	16.9	5.40	0.61	0.19	0.56
	1950	54.6	3.73	0.45	0.60	0.74	41.8	4.26	0.43	0.58	0.71	29.8	4.81	0.37	0.51	0.66	17.1	5.39	0.63	0.41	0.59
	2113	57.1	3.71	0.46	0.61	0.76	43.8	4.26	0.53	0.62	0.71	30.6	4.82	0.59	0.63	0.66	17.3	5.37	0.65	0.64	0.62
67°F	1788	61.4	3.73	0.29	0.43	0.57	48.9	4.27	0.17	0.35	0.52	37.0	4.81	0.14	0.23	0.45	25.1	5.44	0.56	0.19	0.29
	1950	63.6	3.71	0.29	0.44	0.59	50.6	4.26	0.29	0.41	0.52	37.8	4.82	0.33	0.35	0.44	25.1	5.42	0.59	0.34	0.32
	2113	65.8	3.69	0.30	0.45	0.61	52.2	4.26	0.40	0.46	0.52	38.7	4.83	0.51	0.47	0.44	25.1	5.39	0.61	0.48	0.35
71°F	1788	71.5	3.72	0.18	0.30	0.43	58.9	4.26	0.07	0.21	0.36	46.0	4.82	0.21	0.08	0.27	33.9	5.47	0.58	0.27	0.09
	1950	73.3	3.71	0.18	0.31	0.44	60.2	4.26	0.21	0.28	0.35	46.9	4.83	0.35	0.22	0.25	34.1	5.44	0.61	0.33	0.11
	2113	75.1	3.69	0.19	0.32	0.45	61.5	4.27	0.34	0.34	0.34	47.9	4.84	0.49	0.36	0.23	34.3	5.42	0.65	0.38	0.12

13 TON - HIGH EFFICIENCY LCM156U5M WITH HUMIDITROL® (COMPRESSOR 1-2 IN REHEAT , COMPRESSOR 3 ON)

Entering Wet Bulb Temperature	Total Air Volume	Outdoor Air Temperature Entering Outdoor Coil																			
		65°F					75°F					85°F					95°F				
		Total Cool Cap.	Comp. Motor Input	Sensible To Total Ratio (S/T)			Total Cool Cap.	Comp. Motor Input	Sensible To Total Ratio (S/T)			Total Cool Cap.	Comp. Motor Input	Sensible To Total Ratio (S/T)			Total Cool Cap.	Comp. Motor Input	Sensible To Total Ratio (S/T)		
				Dry Bulb					Dry Bulb					Dry Bulb					Dry Bulb		
cfm	kBtuh	kW	75°F	80°F	85°F	kBtuh	kW	75°F	80°F	85°F	kBtuh	kW	75°F	80°F	85°F	kBtuh	kW	75°F	80°F	85°F	
63°F	3575	105.2	5.58	0.52	0.68	0.80	84.8	6.37	0.48	0.67	0.83	65.0	7.28	0.40	0.66	0.82	48.0	8.25	0.23	0.54	0.78
	3900	109.3	5.56	0.54	0.69	0.82	88.6	6.41	0.47	0.66	0.82	68.3	7.31	0.39	0.63	0.81	49.3	8.24	0.25	0.54	0.79
	4225	113.4	5.55	0.56	0.70	0.84	92.4	6.45	0.47	0.64	0.82	71.5	7.34	0.37	0.59	0.81	50.5	8.23	0.28	0.54	0.80
67°F	3575	118.8	5.58	0.36	0.51	0.65	98.5	6.37	0.30	0.48	0.63	78.4	7.29	0.20	0.41	0.61	60.2	8.26	0.14	0.31	0.54
	3900	123.0	5.56	0.37	0.52	0.67	102.1	6.40	0.29	0.47	0.64	81.3	7.31	0.19	0.41	0.62	61.4	8.25	0.11	0.32	0.57
	4225	127.3	5.53	0.38	0.53	0.68	105.7	6.43	0.28	0.47	0.65	84.2	7.33	0.18	0.40	0.63	62.6	8.23	0.08	0.34	0.60
71°F	3575	134.4	5.57	0.24	0.37	0.50	130.4	6.36	0.16	0.32	0.46	91.6	7.29	0.10	0.23	0.41	71.0	8.28	0.19	0.11	0.32
	3900	136.6	5.55	0.27	0.39	0.51	123.5	6.40	0.22	0.35	0.47	93.2	7.32	0.18	0.28	0.42	71.9	8.27	0.20	0.20	0.34
	4225	138.7	5.54	0.31	0.42	0.53	116.7	6.44	0.28	0.38	0.47	94.8	7.35	0.25	0.33	0.42	72.8	8.25	0.22	0.29	0.36

15 TON - HIGH EFFICIENCY LCM180U5M WITH HUMIDITROL® (COMPRESSOR 1-2 IN REHEAT)

Entering Wet Bulb Temperature	Total Air Volume	Outdoor Air Temperature Entering Outdoor Coil																			
		65°F					75°F					85°F					95°F				
		Total Cool Cap.	Comp. Motor Input	Sensible To Total Ratio (S/T)			Total Cool Cap.	Comp. Motor Input	Sensible To Total Ratio (S/T)			Total Cool Cap.	Comp. Motor Input	Sensible To Total Ratio (S/T)			Total Cool Cap.	Comp. Motor Input	Sensible To Total Ratio (S/T)		
				Dry Bulb					Dry Bulb					Dry Bulb					Dry Bulb		
cfm	kBtuh	kW	75°F	80°F	85°F	kBtuh	kW	75°F	80°F	85°F	kBtuh	kW	75°F	80°F	85°F	kBtuh	kW	75°F	80°F	85°F	
63°F	2063	62.4	4.44	0.42	0.59	0.73	49.0	5.00	0.33	0.53	0.70	36.6	5.61	0.16	0.44	0.65	23.5	6.30	0.35	0.24	0.55
	2250	65.0	4.43	0.44	0.60	0.75	51.1	5.02	0.38	0.55	0.71	37.6	5.63	0.28	0.49	0.67	23.8	6.28	0.36	0.37	0.60
	2438	67.6	4.42	0.45	0.61	0.76	53.1	5.03	0.42	0.57	0.73	38.6	5.65	0.39	0.54	0.69	24.1	6.26	0.36	0.50	0.65
67°F	2063	73.5	4.45	0.28	0.43	0.55	59.8	5.02	0.18	0.35	0.52	46.7	5.65	0.06	0.22	0.44	32.8	6.32	0.41	0.09	0.31
	2250	76.0	4.43	0.29	0.44	0.57	61.7	5.03	0.26	0.39	0.52	47.6	5.66	0.22	0.32	0.44	33.2	6.31	0.42	0.25	0.35
	2438	78.5	4.42	0.30	0.44	0.59	63.5	5.05	0.34	0.43	0.52	48.5	5.67	0.38	0.42	0.45	33.5	6.29	0.43	0.40	0.38
71°F	2063	84.4	4.46	0.17	0.29	0.41	71.4	5.04	0.06	0.21	0.36	57.2	5.69	0.16	0.08	0.27	43.6	6.39	0.46	0.19	0.12
	2250	87.3	4.45	0.17	0.30	0.43	73.0	5.06	0.17	0.26	0.35	58.1	5.71	0.28	0.20	0.26	43.6	6.38	0.49	0.26	0.13
	2438	90.1	4.43	0.17	0.31	0.44	74.6	5.07	0.29	0.32	0.34	59.1	5.72	0.40	0.33	0.25	43.5	6.37	0.52	0.34	0.15

15 TON HIGH EFFICIENCY LCM180U5M WITH HUMIDITROL® (COMPRESSOR 1-2 IN REHEAT , COMPRESSOR 3 ON)

Entering Wet Bulb Temperature	Total Air Volume	Outdoor Air Temperature Entering Outdoor Coil																			
		65°F					75°F					85°F					95°F				
		Total Cool Cap.	Comp. Motor Input	Sensible To Total Ratio (S/T)			Total Cool Cap.	Comp. Motor Input	Sensible To Total Ratio (S/T)			Total Cool Cap.	Comp. Motor Input	Sensible To Total Ratio (S/T)			Total Cool Cap.	Comp. Motor Input	Sensible To Total Ratio (S/T)		
				Dry Bulb					Dry Bulb					Dry Bulb					Dry Bulb		
cfm	kBtuh	kW	75°F	80°F	85°F	kBtuh	kW	75°F	80°F	85°F	kBtuh	kW	75°F	80°F	85°F	kBtuh	kW	75°F	80°F	85°F	
63°F	4125	121.0	6.67	0.52	0.68	0.81	101.6	7.59	0.47	0.66	0.82	81.0	8.62	0.40	0.64	0.82	59.9	9.74	0.27	0.59	0.83
	4500	125.4	6.67	0.54	0.69	0.83	104.7	7.64	0.48	0.66	0.83	83.3	8.66	0.40	0.63	0.83	61.6	9.73	0.30	0.59	0.84
	4875	129.9	6.67	0.55	0.70	0.84	107.7	7.69	0.48	0.66	0.85	85.5	8.70	0.40	0.63	0.85	63.3	9.72	0.33	0.59	0.85
67°F	4125	137.6	6.68	0.36	0.50	0.65	117.4	7.62	0.30	0.47	0.63	96.5	8.66	0.20	0.41	0.61	75.4	9.81	0.05	0.32	0.55
	4500	141.7	6.68	0.38	0.52	0.67	120.3	7.67	0.29	0.47	0.65	98.6	8.71	0.19	0.41	0.62	76.8	9.80	0.07	0.33	0.58
	4875	145.9	6.69	0.39	0.54	0.69	123.3	7.72	0.29	0.48	0.67	100.7	8.75	0.18	0.41	0.64	78.2	9.78	0.08	0.35	0.62
71°F	4125	154.8	6.71	0.23	0.37	0.49	134.7	7.66	0.16	0.32	0.46	111.1	8.69	0.07	0.24	0.41	88.9	9.88	0.18	0.13	0.34
	4500	158.3	6.71	0.24	0.38	0.51	136.8	7.71	0.20	0.34	0.47	113.5	8.75	0.14	0.28	0.42	90.9	9.86	0.19	0.21	0.36
	4875	161.8	6.71	0.26	0.39	0.53	138.9	7.76	0.24	0.36	0.48	115.9	8.80	0.22	0.33	0.43	92.9	9.85	0.20	0.29	0.39

HUMIDITROL™ + DEHUMIDIFICATION SYSTEM RATINGS

17.5 TON - HIGH EFFICIENCY LCM210U5M WITH HUMIDITROL® (COMPRESSOR 1-2 IN REHEAT)

Entering Wet Bulb Temperature	Total Air Volume	Outdoor Air Temperature Entering Outdoor Coil																			
		65°F					75°F					85°F					95°F				
		Total Cool Cap.	Comp. Motor Input	Sensible To Total Ratio (S/T)			Total Cool Cap.	Comp. Motor Input	Sensible To Total Ratio (S/T)			Total Cool Cap.	Comp. Motor Input	Sensible To Total Ratio (S/T)			Total Cool Cap.	Comp. Motor Input	Sensible To Total Ratio (S/T)		
				Dry Bulb					Dry Bulb					Dry Bulb					Dry Bulb		
cfm	kBtuh	kW	75°F	80°F	85°F	kBtuh	kW	75°F	80°F	85°F	kBtuh	kW	75°F	80°F	85°F	kBtuh	kW	75°F	80°F	85°F	
63°F	2406	47.3	4.54	0.41	0.67	0.90	47.7	4.39	0.41	0.70	0.92	36.9	4.84	0.33	0.71	0.88	23.4	5.50	-0.03	0.53	0.89
	2625	49.0	4.49	0.44	0.69	0.93	44.5	4.58	0.37	0.68	0.96	34.6	4.97	0.26	0.67	0.97	23.2	5.47	0.02	0.56	1.00
	2844	50.6	4.44	0.47	0.71	0.96	41.4	4.77	0.33	0.67	1.01	32.2	5.10	0.20	0.63	1.06	23.0	5.43	0.07	0.59	1.11
67°F	2406	66.5	4.12	0.30	0.48	0.67	60.1	4.32	0.25	0.46	0.66	47.9	4.85	0.11	0.34	0.61	33.3	5.53	-0.21	0.15	0.54
	2625	68.5	4.08	0.32	0.50	0.69	59.2	4.42	0.20	0.44	0.67	46.9	4.92	0.04	0.33	0.63	33.5	5.50	-0.20	0.18	0.58
	2844	70.6	4.04	0.34	0.53	0.71	58.3	4.51	0.16	0.42	0.68	46.0	4.99	-0.02	0.32	0.65	33.7	5.46	-0.19	0.22	0.62
71°F	2406	86.4	3.70	0.22	0.37	0.51	72.2	4.29	0.09	0.28	0.48	59.3	4.85	-0.04	0.18	0.39	45.5	5.50	-0.33	-0.02	0.25
	2625	89.3	3.65	0.22	0.38	0.54	74.4	4.26	0.06	0.27	0.48	60.1	4.85	-0.10	0.15	0.39	45.4	5.49	-0.35	-0.02	0.28
	2844	92.1	3.60	0.23	0.40	0.57	76.5	4.23	0.03	0.26	0.48	60.9	4.85	-0.17	0.12	0.40	45.2	5.48	-0.37	-0.03	0.31

17.5 TON - HIGH EFFICIENCY LCM210U5M WITH HUMIDITROL® (COMPRESSOR 1-2 IN REHEAT, COMPRESSOR 3-4 ON)

Entering Wet Bulb Temperature	Total Air Volume	Outdoor Air Temperature Entering Outdoor Coil																			
		65°F					75°F					85°F					95°F				
		Total Cool Cap.	Comp. Motor Input	Sensible To Total Ratio (S/T)			Total Cool Cap.	Comp. Motor Input	Sensible To Total Ratio (S/T)			Total Cool Cap.	Comp. Motor Input	Sensible To Total Ratio (S/T)			Total Cool Cap.	Comp. Motor Input	Sensible To Total Ratio (S/T)		
				Dry Bulb					Dry Bulb					Dry Bulb					Dry Bulb		
cfm	kBtuh	kW	75°F	80°F	85°F	kBtuh	kW	75°F	80°F	85°F	kBtuh	kW	75°F	80°F	85°F	kBtuh	kW	75°F	80°F	85°F	
63°F	4813	135.3	8.17	0.54	0.71	0.85	115.1	9.27	0.51	0.71	0.87	96.5	10.43	0.47	0.71	0.88	87.3	11.43	0.43	0.69	0.88
	5250	139.2	8.15	0.55	0.72	0.88	120.5	9.25	0.53	0.72	0.89	102.5	10.37	0.49	0.71	0.90	89.3	11.41	0.46	0.70	0.90
	5688	143.1	8.14	0.57	0.74	0.90	125.9	9.22	0.54	0.73	0.91	108.6	10.31	0.52	0.72	0.92	91.3	11.39	0.49	0.71	0.92
67°F	4813	151.9	8.34	0.35	0.52	0.66	132.2	9.41	0.31	0.49	0.66	128.9	10.06	0.30	0.51	0.67	105.5	11.48	0.22	0.46	0.65
	5250	155.7	8.33	0.37	0.53	0.69	137.3	9.38	0.32	0.51	0.69	127.1	10.22	0.29	0.51	0.70	106.8	11.45	0.23	0.47	0.69
	5688	159.6	8.32	0.38	0.55	0.71	142.4	9.35	0.34	0.53	0.72	125.3	10.39	0.29	0.51	0.73	108.1	11.42	0.24	0.49	0.73
71°F	4813	175.5	8.30	0.23	0.37	0.51	170.6	8.82	0.23	0.38	0.52	151.2	9.96	0.16	0.33	0.49	127.1	11.46	0.07	0.26	0.50
	5250	181.4	8.25	0.23	0.38	0.53	168.7	9.05	0.20	0.37	0.52	148.7	10.16	0.14	0.32	0.49	126.5	11.46	0.07	0.26	0.48
	5688	187.3	8.19	0.23	0.39	0.56	166.8	9.28	0.18	0.35	0.52	146.3	10.37	0.12	0.30	0.49	125.8	11.46	0.06	0.26	0.46

20 TON - HIGH EFFICIENCY LCM240U5M WITH HUMIDITROL® (COMPRESSOR 1-2 IN REHEAT)

Entering Wet Bulb Temperature	Total Air Volume	Outdoor Air Temperature Entering Outdoor Coil																			
		65°F					75°F					85°F					95°F				
		Total Cool Cap.	Comp. Motor Input	Sensible To Total Ratio (S/T)			Total Cool Cap.	Comp. Motor Input	Sensible To Total Ratio (S/T)			Total Cool Cap.	Comp. Motor Input	Sensible To Total Ratio (S/T)			Total Cool Cap.	Comp. Motor Input	Sensible To Total Ratio (S/T)		
				Dry Bulb					Dry Bulb					Dry Bulb					Dry Bulb		
cfm	kBtuh	kW	75°F	80°F	85°F	kBtuh	kW	75°F	80°F	85°F	kBtuh	kW	75°F	80°F	85°F	kBtuh	kW	75°F	80°F	85°F	
63°F	2750	58.1	5.83	0.40	0.65	0.86	58.8	5.68	0.40	0.65	0.84	44.3	6.19	0.30	0.66	0.89	29.5	6.96	1.04	0.48	0.86
	3000	61.7	5.77	0.42	0.66	0.88	56.0	5.90	0.36	0.63	0.88	42.7	6.36	0.25	0.61	0.91	29.3	6.96	0.56	0.50	0.91
	3250	65.3	5.70	0.44	0.67	0.90	53.3	6.12	0.32	0.62	0.92	41.2	6.54	0.20	0.57	0.93	29.1	6.95	0.08	0.52	0.95
67°F	2750	81.3	5.33	0.28	0.47	0.64	74.5	5.59	0.22	0.43	0.62	57.7	6.23	0.10	0.35	0.59	41.5	7.04	1.25	0.15	0.50
	3000	85.1	5.27	0.30	0.48	0.66	73.7	5.70	0.42	0.54	0.64	57.3	6.32	0.51	0.57	0.61	41.2	7.03	1.24	0.54	0.56
	3250	88.8	5.20	0.31	0.50	0.69	72.8	5.80	0.61	0.64	0.67	56.9	6.41	0.91	0.78	0.64	40.9	7.02	1.22	0.92	0.62
71°F	2750	105.4	4.78	0.21	0.36	0.49	87.7	5.63	0.09	0.27	0.43	71.4	6.27	1.05	0.17	0.37	42.5	7.13	1.00	1.03	0.24
	3000	107.5	4.83	0.20	0.36	0.51	86.6	5.62	0.27	0.36	0.44	66.4	6.31	0.89	0.36	0.37	39.9	7.11	1.00	0.84	0.27
	3250	109.5	4.88	0.19	0.36	0.53	85.5	5.62	0.46	0.46	0.45	61.5	6.35	0.73	0.55	0.38	37.4	7.09	1.00	0.65	0.30

20 TON - HIGH EFFICIENCY LCM240U5M WITH HUMIDITROL® (COMPRESSOR 1-2 IN REHEAT, COMPRESSOR 3-4 ON)

Entering Wet Bulb Temperature	Total Air Volume	Outdoor Air Temperature Entering Outdoor Coil																			
		65°F					75°F					85°F					95°F				
		Total Cool Cap.	Comp. Motor Input	Sensible To Total Ratio (S/T)			Total Cool Cap.	Comp. Motor Input	Sensible To Total Ratio (S/T)			Total Cool Cap.	Comp. Motor Input	Sensible To Total Ratio (S/T)			Total Cool Cap.	Comp. Motor Input	Sensible To Total Ratio (S/T)		
				Dry Bulb					Dry Bulb					Dry Bulb					Dry Bulb		
cfm	kBtuh	kW	75°F	80°F	85°F	kBtuh	kW	75°F	80°F	85°F	kBtuh	kW	75°F	80°F	85°F	kBtuh	kW	75°F	80°F	85°F	
63°F	5500	160.7	10.46	0.51	0.67	0.80	129.3	11.74	0.50	0.68	0.85	109.6	12.99	0.46	0.70	0.86	98.6	14.09	0.45	0.67	0.89
	6000	161.1	10.42	0.54	0.70	0.84	135.6	11.68	0.52	0.70	0.88	115.9	12.91	0.49	0.71	0.89	100.6	14.07	0.47	0.69	0.91
	6500	161.5	10.39	0.57	0.72	0.88	141.9	11.61	0.54	0.72	0.90	122.2	12.84	0.51	0.71	0.91	102.6	14.06	0.49	0.71	0.93
67°F	5500	177.5	10.65	0.33	0.49	0.63	151.7	11.80	0.29	0.49	0.66	144.4	12.56	0.30	0.50	0.67	119.3	14.16	0.21	0.45	0.66
	6000	178.5	10.61	0.35	0.51	0.66	156.0	11.78	0.31	0.50	0.68	142.8	12.75	0.29	0.50	0.69	120.7	14.15	0.23	0.46	0.69
	6500	179.4	10.57	0.37	0.53	0.69	160.3	11.76	0.33	0.51	0.70	141.2	12.95	0.29	0.50	0.71	122.1	14.13	0.24	0.48	0.72
71°F	5500	204.3	10.48	0.21	0.36	0.49	195.9	11.03	0.22	0.37	0.51	171.4	12.47	0.16	0.33	0.49	140.5	14.27	0.06	0.26	0.45
	6000	212.3	10.23	0.23	0.38	0.52	195.5	11.22	0.20	0.37	0.52	170.6	12.65	0.14	0.32	0.50	142.5	14.25	0.05	0.26	0.47
	6500	220.4	9.98	0.26	0.41	0.56	195.1	11.40	0.19	0.36	0.53	169.8	12.82	0.11	0.31	0.51	144.5	14.24	0.04	0.27	0.49

HUMIDITROL™ + DEHUMIDIFICATION SYSTEM RATINGS

25 TON - HIGH EFFICIENCY LGM300U5M WITH HUMIDITROL® (COMPRESSOR 1-2 IN REHEAT)

Entering Wet Bulb Temperature	Total Air Volume	Outdoor Air Temperature Entering Outdoor Coil																			
		65°F					75°F					85°F					95°F				
		Total Cool Cap.	Comp. Motor Input	Sensible To Total Ratio (S/T)			Total Cool Cap.	Comp. Motor Input	Sensible To Total Ratio (S/T)			Total Cool Cap.	Comp. Motor Input	Sensible To Total Ratio (S/T)			Total Cool Cap.	Comp. Motor Input	Sensible To Total Ratio (S/T)		
				Dry Bulb					Dry Bulb					Dry Bulb					Dry Bulb		
		cfm	kBtuh	kW	75°F	80°F	85°F	kBtuh	kW	75°F	80°F	85°F	kBtuh	kW	75°F	80°F	85°F	kBtuh	kW	75°F	80°F
63°F	3438	58.1	5.8	0.40	0.65	0.86	58.8	5.7	0.40	0.65	0.84	44.3	6.2	0.30	0.66	0.89	29.5	7.0	1.04	0.48	0.86
	3750	61.7	5.8	0.42	0.66	0.88	56.0	5.9	0.36	0.63	0.88	42.7	6.4	0.25	0.61	0.91	29.3	6.96	0.56	0.50	0.91
	4063	65.3	5.7	0.44	0.67	0.90	53.3	6.1	0.32	0.62	0.92	41.2	6.5	0.20	0.57	0.93	29.1	7.0	0.08	0.52	0.95
67°F	3438	81.3	5.3	0.28	0.47	0.64	74.5	5.6	0.22	0.43	0.62	57.7	6.2	0.10	0.35	0.59	41.5	7.0	1.25	0.15	0.50
	3750	85.1	5.3	0.30	0.48	0.66	73.7	5.7	0.42	0.54	0.64	57.3	6.3	0.51	0.57	0.61	41.2	7.03	1.24	0.54	0.56
	4063	88.8	5.2	0.31	0.50	0.69	72.8	5.8	0.61	0.64	0.67	56.9	6.4	0.91	0.78	0.64	40.9	7.0	1.22	0.92	0.62
71°F	3438	105.4	4.8	0.21	0.36	0.49	87.7	5.6	0.09	0.27	0.43	71.4	6.3	1.05	0.17	0.37	42.5	7.1	1.00	1.03	0.24
	3750	107.5	4.8	0.20	0.36	0.51	86.6	5.6	0.27	0.36	0.44	66.4	6.3	0.89	0.36	0.37	39.9	7.11	1.00	0.84	0.27
	4063	109.5	4.9	0.19	0.36	0.53	85.5	5.6	0.46	0.46	0.45	61.5	6.4	0.73	0.55	0.38	37.4	7.1	1.00	0.65	0.30

25 TON - HIGH EFFICIENCY LGM300U5M WITH HUMIDITROL® (COMPRESSOR 1-2 IN REHEAT, COMPRESSOR 3-4 ON)

Entering Wet Bulb Temperature	Total Air Volume	Outdoor Air Temperature Entering Outdoor Coil																			
		65°F					75°F					85°F					95°F				
		Total Cool Cap.	Comp. Motor Input	Sensible To Total Ratio (S/T)			Total Cool Cap.	Comp. Motor Input	Sensible To Total Ratio (S/T)			Total Cool Cap.	Comp. Motor Input	Sensible To Total Ratio (S/T)			Total Cool Cap.	Comp. Motor Input	Sensible To Total Ratio (S/T)		
				Dry Bulb					Dry Bulb					Dry Bulb					Dry Bulb		
		cfm	kBtuh	kW	75°F	80°F	85°F	kBtuh	kW	75°F	80°F	85°F	kBtuh	kW	75°F	80°F	85°F	kBtuh	kW	75°F	80°F
63°F	6875	192.5	13.7	0.54	0.71	0.84	160.9	15.3	0.53	0.72	0.89	136.9	16.9	0.50	0.72	0.91	126.8	18.4	0.45	0.72	0.89
	7500	196.4	13.7	0.56	0.72	0.87	168.9	15.3	0.55	0.73	0.90	145.3	16.9	0.53	0.73	0.91	128.5	18.37	0.49	0.73	0.90
	8125	200.3	13.7	0.58	0.74	0.90	177.0	15.2	0.57	0.74	0.91	153.6	16.8	0.55	0.73	0.92	130.3	18.4	0.54	0.73	0.92
67°F	6875	212.7	13.9	0.36	0.52	0.67	181.9	15.7	0.32	0.50	0.70	173.8	16.8	0.30	0.49	0.70	153.7	18.4	0.26	0.49	0.68
	7500	217.1	13.9	0.37	0.54	0.70	190.8	15.5	0.33	0.52	0.71	175.9	16.9	0.31	0.51	0.71	155.0	18.42	0.27	0.50	0.71
	8125	221.4	13.9	0.38	0.55	0.72	199.7	15.4	0.35	0.54	0.73	178.0	16.9	0.31	0.52	0.73	156.3	18.4	0.28	0.51	0.74
71°F	6875	241.0	14.1	0.21	0.36	0.51	234.4	15.0	0.23	0.37	0.53	213.1	16.5	0.18	0.36	0.51	179.6	18.6	0.08	0.30	0.48
	7500	250.0	13.9	0.22	0.38	0.53	233.0	15.2	0.21	0.37	0.54	208.6	16.8	0.16	0.35	0.53	178.2	18.63	0.08	0.30	0.51
	8125	259.1	13.8	0.23	0.39	0.55	231.6	15.4	0.18	0.37	0.55	204.1	17.0	0.13	0.34	0.55	176.7	18.7	0.08	0.31	0.55

BLOWER DATA

BLOWER TABLE INCLUDES RESISTANCE FOR BASE UNIT ONLY WITH DRY INDOOR COIL & AIR FILTERS IN PLACE

FOR ALL UNITS ADD:

- 1 - Wet indoor coil air resistance of selected unit.
- 2 - Any factory installed options air resistance (electric heat, Economizer, etc.)
- 3 - Any field installed accessories air resistance (electric heat, duct resistance, diffuser, etc.)

Then determine from blower table blower motor output and drive required.

See page 36 for wet coil and option/accessory air resistance data.

See page 36 for factory installed drive kit specifications.

MINIMUM AIR VOLUME REQUIRED FOR USE WITH OPTIONAL ELECTRIC HEAT

15-60 kW Electric Heat - 5200 cfm minimum air volume.

90 kW Electric Heat - 6000 cfm minimum air volume.

Air Volume cfm	TOTAL STATIC PRESSURE - Inches Water Gauge (Pa)																									
	0.20		0.40		0.60		0.80		1.00		1.20		1.40		1.60		1.80		2.00		2.20		2.40		2.60	
	RPM	BHP	RPM	BHP	RPM	BHP	RPM	BHP	RPM	BHP	RPM	BHP	RPM	BHP	RPM	BHP	RPM	BHP	RPM	BHP	RPM	BHP	RPM	BHP	RPM	BHP
2750	385	0.30	505	0.50	600	0.70	680	0.90	755	1.10	820	1.30	885	1.50	950	1.70	1015	1.90	1080	2.10	1145	2.30	1210	2.50	1275	2.70
3000	395	0.35	515	0.55	610	0.75	685	1.00	760	1.20	825	1.45	890	1.65	955	1.85	1020	2.05	1085	2.25	1150	2.45	1215	2.65	1280	2.85
3250	405	0.40	520	0.60	615	0.85	695	1.10	765	1.30	830	1.60	895	1.80	960	2.00	1025	2.20	1090	2.40	1155	2.60	1220	2.80	1285	3.00
3500	415	0.45	530	0.70	620	0.95	700	1.20	775	1.45	840	1.70	905	1.95	970	2.15	1035	2.35	1100	2.55	1165	2.75	1230	2.95	1295	3.15
3750	425	0.50	540	0.75	630	1.05	710	1.30	785	1.60	845	1.85	905	2.05	970	2.25	1035	2.45	1100	2.65	1165	2.85	1230	3.05	1295	3.25
4000	435	0.55	545	0.85	635	1.10	715	1.40	785	1.70	850	2.00	910	2.20	975	2.40	1040	2.60	1105	2.80	1170	3.00	1235	3.20	1300	3.40
4250	445	0.60	555	0.90	645	1.25	725	1.55	795	1.85	855	2.15	915	2.35	980	2.55	1045	2.75	1110	2.95	1175	3.15	1240	3.35	1305	3.55
4500	455	0.70	565	1.00	655	1.35	730	1.65	800	2.00	865	2.35	925	2.55	990	2.75	1055	2.95	1120	3.15	1185	3.35	1250	3.55	1315	3.75
4750	470	0.75	575	1.10	660	1.45	740	1.80	810	2.15	870	2.50	930	2.70	995	2.90	1060	3.10	1125	3.30	1190	3.50	1255	3.70	1320	3.90
5000	480	0.85	585	1.25	670	1.60	750	1.95	815	2.30	880	2.70	940	2.90	1005	3.10	1070	3.30	1135	3.50	1200	3.70	1265	3.90	1330	4.10
5250	495	0.95	595	1.35	680	1.70	755	2.10	825	2.50	890	2.90	945	3.05	1010	3.25	1075	3.45	1140	3.65	1205	3.85	1270	4.05	1335	4.25
5500	505	1.05	605	1.45	690	1.85	765	2.25	835	2.65	895	3.05	955	3.25	1020	3.45	1085	3.65	1150	3.85	1215	4.05	1280	4.25	1345	4.45
5750	520	1.15	615	1.60	700	2.00	775	2.45	840	2.85	905	3.25	960	3.45	1025	3.65	1090	3.85	1155	4.05	1220	4.25	1285	4.45	1350	4.65
6000	530	1.30	630	1.75	710	2.15	785	2.60	850	3.05	910	3.45	970	3.65	1035	3.85	1100	4.05	1165	4.25	1230	4.45	1295	4.65	1360	4.85
6250	545	1.40	640	1.90	720	2.35	795	2.80	860	3.25	920	3.70	975	3.85	1040	4.05	1105	4.25	1170	4.45	1235	4.65	1300	4.85	1365	5.05
6500	560	1.55	650	2.05	730	2.50	805	3.00	870	3.45	930	3.95	985	4.10	1050	4.30	1115	4.50	1180	4.70	1245	4.90	1310	5.10	1375	5.30
6750	570	1.70	665	2.20	745	2.70	815	3.20	880	3.70	940	4.20	995	4.35	1060	4.55	1125	4.75	1190	4.95	1255	5.15	1320	5.35	1385	5.55
7000	585	1.85	675	2.35	755	2.90	825	3.40	890	3.95	950	4.45	1005	4.60	1070	4.80	1135	5.00	1200	5.20	1265	5.40	1330	5.60	1395	5.80
7250	600	2.00	690	2.60	765	3.10	835	3.65	900	4.15	955	4.65	1015	4.80	1080	5.00	1145	5.20	1210	5.40	1275	5.60	1340	5.80	1405	6.00
7500	615	2.20	700	2.75	775	3.30	845	3.85	910	4.45	965	4.95	1020	5.05	1085	5.25	1150	5.45	1215	5.65	1280	5.85	1350	6.05	1415	6.20
7750	630	2.40	715	3.00	790	3.55	855	4.10	920	4.70	975	5.25	1030	5.35	1095	5.55	1160	5.75	1225	5.95	1290	6.15	1360	6.35	1425	6.50
8000	640	2.55	725	3.20	800	3.80	865	4.35	930	4.95	985	5.50	1040	5.60	1105	5.80	1170	6.00	1235	6.20	1300	6.40	1370	6.60	1435	6.75
8250	655	2.80	740	3.40	810	4.00	880	4.65	940	5.25	995	5.85	1050	6.00	1115	6.20	1180	6.40	1245	6.60	1310	6.80	1380	7.00	1445	7.15
8500	670	3.00	750	3.65	825	4.30	890	4.90	950	5.55	1005	6.15	1060	6.30	1125	6.50	1190	6.70	1255	6.90	1320	7.10	1390	7.30	1455	7.45
8750	685	3.25	765	3.90	835	4.55	900	5.20	960	5.85	1015	6.45	1070	6.60	1135	6.80	1200	7.00	1265	7.20	1330	7.40	1400	7.60	1465	7.75
9000	700	3.50	780	4.20	850	4.85	910	5.50	970	6.15	1025	6.80	1080	7.00	1145	7.20	1210	7.40	1275	7.60	1340	7.80	1410	8.00	1475	8.15
9250	715	3.75	790	4.45	860	5.15	925	5.85	985	6.55	1040	7.20	1100	7.40	1165	7.60	1230	7.80	1295	8.00	1360	8.20	1430	8.40	1495	8.55
9500	730	4.00	805	4.75	875	5.45	935	6.15	995	6.90	1050	7.60	1110	7.80	1175	8.00	1240	8.20	1305	8.40	1370	8.60	1440	8.80	1505	8.95
9750	745	4.30	820	5.05	885	5.75	950	6.55	1005	7.20	1060	7.95	1120	8.10	1185	8.30	1250	8.50	1315	8.70	1380	8.90	1450	9.10	1515	9.25
10,000	760	4.60	835	5.40	900	6.15	960	6.85	1015	7.60	1070	8.35	1130	8.50	1195	8.70	1260	8.90	1325	9.10	1390	9.30	1460	9.50	1525	9.65
10,250	775	4.90	845	5.65	910	6.45	970	7.20	1030	8.00	1080	8.75	1140	8.90	1205	9.10	1270	9.30	1335	9.50	1400	9.70	1470	9.90	1540	10.05
10,500	790	5.20	860	6.00	925	6.85	985	7.65	1040	8.40	1095	9.20	1145	9.40	1210	9.60	1275	9.80	1340	10.00	1405	10.20	1475	10.40	1550	10.55
10,750	805	5.55	875	6.40	940	7.25	1000	8.05	1055	8.85	1105	9.65	1155	9.80	1220	10.00	1285	10.20	1350	10.40	1415	10.60	1485	10.80	1560	10.95
11,000	820	5.90	890	6.80	950	7.60	1010	8.45	1065	9.30	1115	10.05	1165	10.20	1230	10.40	1295	10.60	1360	10.80	1425	11.00	1495	11.20	1570	11.35

BLOWER DATA

FACTORY INSTALLED BELT DRIVE KIT SPECIFICATIONS

Nominal HP	Maximum HP	Drive Kit Number	RPM Range
3	3.45	1	535 - 725
3	3.45	2	710 - 965
5	5.75	3	685 - 856
5	5.75	4	850 - 1045
5	5.75	5	945 - 1185
7.5	8.63	6	850 - 1045
7.5	8.63	7	945 - 1185
7.5	8.63	8	1045 - 1285
10	11.50	7	945 - 1185
10	11.50	10	1045 - 1285
10	11.50	11	1135 - 1330

NOTE - Using total air volume and system static pressure requirements determine from blower performance tables rpm and motor output required. Maximum usable output of motors furnished are shown. In Canada, nominal motor output is also maximum usable motor output. If motors of comparable output are used, be sure to keep within the service factor limitations outlined on the motor nameplate.

NOTE - Blower motor service factor = 1.0.

FACTORY INSTALLED OPTIONS/FIELD INSTALLED ACCESSORY AIR RESISTANCE

Air Volume cfm	Wet Indoor Coil		Humiditrol®+ Reheat Coil	Electric Heat	Economizer	Filters			Horizontal Roof Curb	
	156 180	210 240 300				MERV 8	MERV 13	MERV 16	156 thru 240	300
	in. w.g.	in. w.g.							in. w.g.	in. w.g.
2750	.01	.02	.01	---	---	.01	.03	0.06	.03	-
3000	.01	.02	.01	---	---	.01	.03	0.06	.04	-
3250	.01	.03	.01	---	---	.01	.04	0.07	.04	.01
3500	.01	.03	.02	---	---	.01	.04	0.08	.05	.01
3750	.01	.03	.02	---	---	.01	.04	0.08	.05	.01
4000	.02	.04	.02	---	---	.01	.04	0.09	.06	.02
4250	.02	.04	.02	---	---	.01	.05	0.10	.07	.02
4500	.02	.05	.02	---	---	.01	.05	0.10	.07	.02
4750	.02	.05	.02	---	---	.02	.05	0.11	.08	.03
5000	.02	.05	.02	---	---	.02	.06	0.12	.08	.03
5250	.02	.06	.03	---	---	.02	.06	0.12	.09	.04
5500	.02	.07	.03	---	---	.02	.06	0.13	.10	.04
5750	.03	.07	.03	---	---	.02	.07	0.14	.11	.05
6000	.03	.08	.03	.01	---	.03	.07	0.14	.11	.06
6250	.03	.08	.03	.01	.01	.03	.07	0.15	.12	.07
6500	.03	.09	.04	.01	.02	.03	.08	0.16	.13	.08
6750	.04	.10	.04	.01	.03	.03	.08	0.17	.14	.08
7000	.04	.10	.04	.01	.04	.04	.08	0.17	.15	.09
7250	.04	.11	.04	.01	.05	.04	.09	0.18	.16	.10
7500	.05	.12	.05	.01	.06	.04	.09	0.19	.17	.11
8000	.05	.13	.05	.02	.09	.05	.10	0.21	.19	.13
8500	.06	.15	.05	.02	.11	.05	.10	0.22	.21	.15
9000	.07	.16	.06	.04	.14	.06	.11	0.24	.24	.17
9500	.08	.18	.07	.05	.16	.07	.12	0.25	.26	.19
10,000	.08	.20	.07	.06	.19	.07	.12	0.27	.29	.21
10,500	.09	.22	.08	.09	.22	.08	.13	0.29	.31	.24
11,000	.11	.24	.08	.11	.25	.09	.14	0.30	.34	.27

BLOWER DATA

POWER EXHAUST FAN PERFORMANCE

Return Air System Static Pressure	Air Volume Exhausted
in. w.g.	cfm
0.00	8630
0.05	8210
0.10	7725
0.15	7110
0.20	6470
0.25	5790
0.30	5060
0.35	4300
0.40	3510
0.45	2690
0.50	1840

CEILING DIFFUSER AIR RESISTANCE - in. w.g.

Air Volume cfm	Step-Down Diffuser						Flush Diffuser	
	RTD11-185S			RTD11-275S			FD11-185S	FD11-275S
	2 Ends Open	1 Side/2 Ends Open	All Ends & Sides Open	2 Ends Open	1 Side/2 Ends Open	All Ends & Sides Open		
5000	.51	.44	.39	---	---	---	.27	---
5200	.56	.48	.42	---	---	---	.30	---
5400	.61	.52	.45	---	---	---	.33	---
5600	.66	.56	.48	---	---	---	.36	---
5800	.71	.59	.51	---	---	---	.39	---
6000	.76	.63	.55	.36	.31	.27	.42	.29
6200	.80	.68	.59	---	---	---	.46	---
6400	.86	.72	.63	---	---	---	.50	---
6500	---	---	---	.42	.36	.31	---	.34
6600	.92	.77	.67	---	---	---	.54	---
6800	.99	.83	.72	---	---	---	.58	---
7000	1.03	.87	.76	.49	.41	.36	.62	.40
7200	1.09	.92	.80	---	---	---	.66	---
7400	1.15	.97	.84	---	---	---	.70	---
7500	---	---	---	.51	.46	.41	---	.45
7600	1.20	1.02	.88	---	---	---	.74	---
8000	---	---	---	.59	.49	.43	---	.50
8500	---	---	---	.69	.58	.50	---	.57
9000	---	---	---	.79	.67	.58	---	.66
9500	---	---	---	.89	.75	.65	---	.74
10,000	---	---	---	1.00	.84	.73	---	.81
10,500	---	---	---	1.10	.92	.80	---	.89
11,000	---	---	---	1.21	1.01	.88	---	.96

CEILING DIFFUSER AIR THROW DATA - ft.

Size	Air Volume cfm	¹ Effective Throw Range - ft.		Size	Air Volume cfm	¹ Effective Throw Range - ft.	
		RTD11-185S Step-Down	FD11-185S Flush			RTD11-275S Step-Down	FD11-275S Flush
156 180	5600	39 - 49	28 - 37	210 240 300	7200	33 - 38	26 - 35
	5800	42 - 51	29 - 38		7400	35 - 40	28 - 37
	6000	44 - 54	40 - 50		7600	36 - 41	29 - 38
	6200	45 - 55	42 - 51		7800	38 - 43	40 - 50
	6400	46 - 55	43 - 52		8000	39 - 44	42 - 51
	6600	47 - 56	45 - 56		8200	41 - 46	43 - 52
					8400	43 - 49	44 - 54
					8600	44 - 50	46 - 57
					8800	47 - 55	48 - 59

¹ Throw is the horizontal or vertical distance an airstream travels on leaving the outlet or diffuser before the maximum velocity is reduced to 50 ft. per minute. Four sides open.

ELECTRICAL/ELECTRIC HEAT DATA

13 TON

Model		LCM156U5					
¹ Voltage - 60Hz		208/230V-3ph		460V-3ph		575V-3ph	
Compressor 1 (Inverter)	Rated Load Amps	10.2		6.2		5.6	
	Locked Rotor Amps	21		12		12	
Compressor 2 (Non-Inverter)	Rated Load Amps	13.5		6.4		5.1	
	Locked Rotor Amps	120.4		50		41	
Compressor 3 (Non-Inverter)	Rated Load Amps	13.5		6.4		5.1	
	Locked Rotor Amps	120.4		50		41	
Outdoor Fan Motors (4)	Full Load Amps (4 ECM)	2.8		1.4		1.1	
	Total	11.2		5.6		4.4	
Power Exhaust (2) 0.33 HP	Full Load Amps	2.4		1.3		1	
	Total	4.8		2.6		2	
Service Outlet 115V GFI (amps)		15		15		20	
Indoor Blower Motor	HP	3	5	3	5	3	5
	Full Load Amps	10.6	16.7	4.8	7.6	3.9	6.1
² Maximum Overcurrent Protection (MOCP)	Unit Only	70	80	35	40	30	30
	With (2) 0.33 HP Power Exhaust	80	90	40	40	30	35
³ Minimum Circuit Ampacity (MCA)	Unit Only	63	70	31	35	26	28
	With (2) 0.33 HP Power Exhaust	68	75	34	37	28	30

ELECTRIC HEAT DATA

		Electric Heat Voltage	208V	240V	208V	240V	480V	480V	600V	600V
² Maximum Overcurrent Protection (MOCP)	Unit+ Electric Heat	15 kW	70	70	80	80	35	40	30	30
		30 kW	⁴ 100	110	⁴ 100	125	60	60	45	45
		45 kW	150	150	⁴ 150	175	80	80	60	70
		60 kW	⁴ 150	175	⁴ 150	175	80	90	70	70
³ Minimum Circuit Ampacity (MCA)	Unit+ Electric Heat	15 kW	63	63	70	70	31	35	26	28
		30 kW	92	104	100	112	52	55	41	44
		45 kW	131	149	139	157	74	78	60	62
		60 kW	139	158	146	166	79	82	63	66
² Maximum Overcurrent Protection (MOCP)	Unit+ Electric Heat and (2) 0.33 HP Power Exhaust	15 kW	80	80	90	90	40	40	30	35
		30 kW	⁴ 100	110	⁴ 110	125	60	60	45	50
		45 kW	⁴ 150	175	⁴ 150	175	80	90	70	70
		60 kW	⁴ 150	175	175	175	90	90	70	70
³ Minimum Circuit Ampacity (MCA)	Unit+ Electric Heat and (2) 0.33 HP Power Exhaust	15 kW	68	68	75	75	34	37	28	30
		30 kW	98	110	106	118	55	58	44	47
		45 kW	137	155	145	163	77	81	62	65
		60 kW	145	164	152	172	82	85	66	68

NOTE - All units have a minimum Short Circuit Current Rating (SCCR) of 5000 amps.

¹ Extremes of operating range are plus and minus 10% of line voltage.

² HACR type breaker or fuse.

³ Refer to National or Canadian Electrical Code manual to determine wire, fuse and disconnect size requirements.

⁴ Factory installed circuit breaker not available.

ELECTRICAL/ELECTRIC HEAT DATA

15 TON

Model		LCM180U5								
¹ Voltage - 60Hz		208/230V-3ph			460V-3ph			575V-3ph		
Compressor 1 (Inverter)	Rated Load Amps	14.1			7.8			7		
	Locked Rotor Amps	21			12			12		
Compressor 2 (Non-Inverter)	Rated Load Amps	13.5			6.4			5.1		
	Locked Rotor Amps	120.4			50			41		
Compressor 3 (Non-Inverter)	Rated Load Amps	16			7.1			6.4		
	Locked Rotor Amps	156.4			69			47.8		
Outdoor Fan Motors (4)	Full Load Amps (4 ECM)	2.8			1.4			1.1		
	Total	11.2			5.6			4.4		
Power Exhaust (2) 0.33 HP	Full Load Amps	2.4			1.3			1		
	Total	4.8			2.6			2		
Service Outlet 115V GFI (amps)		15			15			20		
Indoor Blower Motor	HP	3	5	7.5	3	5	7.5	3	5	7.5
	Full Load Amps	10.6	16.7	24.2	4.8	7.6	11	3.9	6.1	9
² Maximum Overcurrent Protection (MOCP)	Unit Only	80	90	100	40	40	50	35	35	40
	With (2) 0.33 HP Power Exhaust	90	90	110	40	45	50	35	35	45
³ Minimum Circuit Ampacity (MCA)	Unit Only	70	76	86	34	37	41	29	31	35
	With (2) 0.33 HP Power Exhaust	75	81	90	37	40	44	31	33	37

ELECTRIC HEAT DATA

		Electric Heat Voltage	208V	240V	208V	240V	208V	240V	480V	480V	480V	600V	600V	600V
² Maximum Overcurrent Protection (MOCP)	Unit+ Electric Heat	15 kW	80	80	90	90	100	100	40	40	50	35	35	40
		30 kW	⁴ 100	110	⁴ 100	125	⁴ 110	125	60	60	60	45	45	50
		45 kW	150	150	⁴ 150	175	⁴ 150	175	80	80	90	60	70	70
		60 kW	⁴ 150	175	⁴ 150	175	175	175	80	90	90	70	70	70
³ Minimum Circuit Ampacity (MCA)	Unit+ Electric Heat	15 kW	70	70	76	76	86	86	34	37	41	29	31	35
		30 kW	92	104	100	112	109	121	52	55	59	41	44	48
		45 kW	131	149	139	157	148	166	74	78	82	60	62	66
		60 kW	139	158	146	166	156	175	79	82	86	63	66	69
² Maximum Overcurrent Protection (MOCP)	Unit+ Electric Heat and (2) 0.33 HP Power Exhaust	15 kW	90	90	90	90	110	110	40	45	50	35	35	45
		30 kW	⁴ 100	110	⁴ 110	125	⁴ 125	150	60	60	70	45	50	50
		45 kW	⁴ 150	175	⁴ 150	175	175	175	80	90	90	70	70	70
		60 kW	⁴ 150	175	175	175	⁴ 175	200	90	90	90	70	70	80
³ Minimum Circuit Ampacity (MCA)	Unit+ Electric Heat and (2) 0.33 HP Power Exhaust	15 kW	75	75	81	81	90	90	37	40	44	31	33	37
		30 kW	98	110	106	118	115	127	55	58	63	44	47	50
		45 kW	137	155	145	163	154	172	77	81	85	62	65	68
		60 kW	145	164	152	172	162	181	82	85	90	66	68	72

NOTE - All units have a minimum Short Circuit Current Rating (SCCR) of 5000 amps.

¹ Extremes of operating range are plus and minus 10% of line voltage.

² HACR type breaker or fuse.

³ Refer to National or Canadian Electrical Code manual to determine wire, fuse and disconnect size requirements.

⁴ Factory installed circuit breaker not available.

ELECTRICAL/ELECTRIC HEAT DATA

17.5 TON

Model		LCM210U5								
		208/230V-3ph			460V-3ph			575V-3ph		
¹ Voltage - 60Hz										
Compressor 1 (Inverter)	Rated Load Amps	10.3			6.2			5.6		
	Locked Rotor Amps	21			12			12		
Compressor 2 (Non-Inverter)	Rated Load Amps	13.5			6.4			5.1		
	Locked Rotor Amps	120.4			50			41		
Compressor 3 (Non-Inverter)	Rated Load Amps	13.5			6.4			5.1		
	Locked Rotor Amps	120.4			50			41		
Compressor 4 (Non-Inverter)	Rated Load Amps	13.5			6.4			5.1		
	Locked Rotor Amps	120.4			50			41		
Outdoor Fan Motors (6)	Full Load Amps (6 ECM)	2.8			1.4			1.1		
	Total	16.8			8.4			6.6		
Power Exhaust (2) 0.33 HP	Full Load Amps	2.4			1.3			1		
	Total	4.8			2.6			2		
Service Outlet 115V GFI (amps)		15			15			20		
Indoor Blower Motor	HP	3	5	7.5	3	5	7.5	3	5	7.5
	Full Load Amps	10.6	16.7	24.2	4.8	7.6	11	3.9	6.1	9
² Maximum Overcurrent Protection (MOCP)	Unit Only	90	100	110	45	50	50	35	40	45
	With (2) 0.33 HP Power Exhaust	90	100	125	45	50	60	40	40	45
³ Minimum Circuit Ampacity (MCA)	Unit Only	82	89	98	41	44	48	33	36	39
	With (2) 0.33 HP Power Exhaust	87	94	103	43	46	51	35	38	41

ELECTRIC HEAT DATA

		Electric Heat Voltage	208V	240V	208V	240V	208V	240V	480V	480V	480V	600V	600V	600V
² Maximum Overcurrent Protection (MOCP)	Unit+	15 kW	90	90	100	100	110	110	45	50	50	35	40	45
	Electric Heat	30 kW	⁴ 100	110	⁴ 100	125	⁴ 110	125	60	60	60	45	45	50
		45 kW	150	150	⁴ 150	175	⁴ 150	175	80	80	90	60	70	70
		60 kW	⁴ 150	175	⁴ 150	175	175	175	80	90	90	70	70	70
		90 kW	⁴ 225	250	⁴ 225	250	⁴ 225	250	125	125	125	100	100	100
³ Minimum Circuit Ampacity (MCA)	Unit+	15 kW	82	82	89	89	98	98	41	44	48	33	36	39
	Electric Heat	30 kW	92	104	100	112	109	121	52	55	59	41	44	48
		45 kW	131	149	139	157	148	166	74	78	82	60	62	66
		60 kW	139	158	146	166	156	175	79	82	86	63	66	69
		90 kW	201	230	209	238	218	247	115	118	123	92	95	98
² Maximum Overcurrent Protection (MOCP)	Unit+	15 kW	90	90	100	100	125	125	45	50	60	40	40	45
	Electric Heat and (2) 0.33 HP Power Exhaust	30 kW	⁴ 100	110	⁴ 110	125	⁴ 125	150	60	60	70	45	50	50
		45 kW	⁴ 150	175	⁴ 150	175	175	175	80	90	90	70	70	70
		60 kW	⁴ 150	175	175	175	⁴ 175	200	90	90	90	70	70	80
		90 kW	⁴ 225	250	⁴ 225	250	⁴ 225	⁴ 300	125	125	150	100	100	110
³ Minimum Circuit Ampacity (MCA)	Unit+	15 kW	87	87	94	94	103	103	43	46	51	35	38	41
	Electric Heat and (2) 0.33 HP Power Exhaust	30 kW	98	110	106	118	115	127	55	58	63	44	47	50
		45 kW	137	155	145	163	154	172	77	81	85	62	65	68
		60 kW	145	164	152	172	162	181	82	85	90	66	68	72
		90 kW	207	236	215	244	224	253	118	122	126	94	97	101

NOTE - All units have a minimum Short Circuit Current Rating (SCCR) of 5000 amps.

¹ Extremes of operating range are plus and minus 10% of line voltage.

² HACR type breaker or fuse.

³ Refer to National or Canadian Electrical Code manual to determine wire, fuse and disconnect size requirements.

⁴ Factory installed circuit breaker not available.

ELECTRICAL/ELECTRIC HEAT DATA

20 TON

Model		LCM240U5								
		208/230V-3ph			460V-3ph			575V-3ph		
¹ Voltage - 60Hz										
Compressor 1 (Inverter)	Rated Load Amps	13.3			7.4			6.9		
	Locked Rotor Amps	21			12			12		
Compressor 2 (Non-Inverter)	Rated Load Amps	13.1			6.6			4.8		
	Locked Rotor Amps	93			60			41		
Compressor 3 (Non-Inverter)	Rated Load Amps	13.1			6.6			4.8		
	Locked Rotor Amps	93			60			41		
Compressor 4 (Non-Inverter)	Rated Load Amps	13.1			6.6			4.8		
	Locked Rotor Amps	93			60			41		
Outdoor Fan Motors (6)	Full Load Amps (6 ECM)	2.8			1.4			1.1		
	Total	16.8			8.4			6.6		
Power Exhaust (2) 0.33 HP	Full Load Amps	2.4			1.3			1		
	Total	4.8			2.6			2		
Service Outlet 115V GFI (amps)		15			15			20		
Indoor Blower Motor	HP	5	7.5	10	5	7.5	10	5	7.5	10
	Full Load Amps	16.7	24.2	30.8	7.6	11	14	6.1	9	11
² Maximum Overcurrent Protection (MOCP)	Unit Only	100	110	125	50	60	60	40	45	50
	With (2) 0.33 HP Power Exhaust	110	125	125	50	60	60	40	50	50
³ Minimum Circuit Ampacity (MCA)	Unit Only	91	100	108	46	50	54	36	40	42
	With (2) 0.33 HP Power Exhaust	96	105	113	48	52	56	38	42	44

ELECTRIC HEAT DATA

		Electric Heat Voltage	208V	240V	208V	240V	208V	240V	480V	480V	480V	600V	600V	600V
² Maximum Overcurrent Protection (MOCP)	Unit+ Electric Heat	15 kW	100	100	110	110	125	125	50	60	60	40	45	50
		30 kW	⁴ 100	125	⁴ 110	125	⁴ 125	150	60	60	70	45	50	50
		45 kW	⁴ 150	175	⁴ 150	175	175	175	80	90	90	70	70	70
		60 kW	⁴ 150	175	175	175	⁴ 175	200	90	90	90	70	70	80
		90 kW	⁴ 225	250	⁴ 225	250	⁴ 250	⁴ 300	125	125	150	100	100	110
³ Minimum Circuit Ampacity (MCA)	Unit+ Electric Heat	15 kW	91	91	100	100	108	108	46	50	54	36	40	42
		30 kW	100	112	109	121	117	129	55	59	63	44	48	50
		45 kW	139	157	148	166	156	174	78	82	86	62	66	68
		60 kW	146	166	156	175	164	183	82	86	90	66	69	72
		90 kW	209	238	218	247	227	256	118	123	126	95	98	101
² Maximum Overcurrent Protection (MOCP)	Unit+ Electric Heat and (2) 0.33 HP Power Exhaust	15 kW	110	110	125	125	125	125	50	60	60	40	50	50
		30 kW	⁴ 110	125	⁴ 125	150	⁴ 125	150	60	70	70	50	50	60
		45 kW	⁴ 150	175	175	175	⁴ 175	200	90	90	90	70	70	80
		60 kW	175	175	⁴ 175	200	⁴ 175	200	90	90	100	70	80	80
		90 kW	⁴ 225	250	⁴ 225	⁴ 300	⁴ 250	⁴ 300	125	150	150	100	110	110
³ Minimum Circuit Ampacity (MCA)	Unit+ Electric Heat and (2) 0.33 HP Power Exhaust	15 kW	96	96	105	105	113	113	48	52	56	38	42	44
		30 kW	106	118	115	127	123	135	58	63	66	47	50	53
		45 kW	145	163	154	172	162	180	81	85	89	65	68	71
		60 kW	152	172	162	181	170	189	85	90	93	68	72	74
		90 kW	215	244	224	253	233	262	122	126	130	97	101	103

NOTE - All units have a minimum Short Circuit Current Rating (SCCR) of 5000 amps.

¹ Extremes of operating range are plus and minus 10% of line voltage.

² HACR type breaker or fuse.

³ Refer to National or Canadian Electrical Code manual to determine wire, fuse and disconnect size requirements.

⁴ Factory installed circuit breaker not available.

ELECTRICAL/ELECTRIC HEAT DATA

25 TON

Model		LCM300U5								
¹ Voltage - 60Hz		208/230V-3ph			460V-3ph			575V-3ph		
Compressor 1 (Inverter)	Rated Load Amps	12.9			7.3			6.7		
	Locked Rotor Amps	21			12			12		
Compressor 2 (Non-Inverter)	Rated Load Amps	21.2			9.1			7.7		
	Locked Rotor Amps	156.5			74.8			47.8		
Compressor 3 (Non-Inverter)	Rated Load Amps	22.4			9.1			7.2		
	Locked Rotor Amps	166.2			74.6			54		
Compressor 4 (Non-Inverter)	Rated Load Amps	22.4			9.1			7.2		
	Locked Rotor Amps	166.2			74.6			54		
Outdoor Fan Motors (6)	Full Load Amps (6 ECM)	2.8			1.4			1.1		
	Total	16.8			8.4			6.6		
Power Exhaust (2) 0.33 HP	Full Load Amps	2.4			1.3			1		
	Total	4.8			2.6			2		
Service Outlet 115V GFI (amps)		15			15			20		
Indoor Blower Motor	HP	5	7.5	10	5	7.5	10	5	7.5	10
	Full Load Amps	16.7	24.2	30.8	7.6	11	14	6.1	9	11
² Maximum Overcurrent Protection (MOCP)	Unit Only	125	150	150	60	60	70	50	50	60
	With (2) 0.33 HP Power Exhaust	125	150	150	60	70	70	50	50	60
³ Minimum Circuit Ampacity (MCA)	Unit Only	118	126	135	53	57	61	44	47	50
	With (2) 0.33 HP Power Exhaust	123	131	139	56	60	64	46	49	52

ELECTRIC HEAT DATA

		Electric Heat Voltage	208V	240V	208V	240V	208V	240V	480V	480V	480V	600V	600V	600V
² Maximum Overcurrent Protection (MOCP)	Unit+ Electric Heat	15 kW	125	125	150	150	150	150	60	60	70	50	50	60
		30 kW	125	125	150	150	150	150	60	60	70	50	50	60
		45 kW	⁴ 150	175	⁴ 150	175	175	175	80	90	90	70	70	70
		60 kW	⁴ 150	175	175	175	⁴ 175	200	90	90	90	70	70	80
		90 kW	⁴ 225	250	⁴ 225	250	⁴ 250	⁴ 300	125	125	150	100	100	110
³ Minimum Circuit Ampacity (MCA)	Unit+ Electric Heat	15 kW	118	118	126	126	135	135	53	57	61	44	47	50
		30 kW	118	118	126	126	135	135	55	59	63	44	48	50
		45 kW	139	157	148	166	156	174	78	82	86	62	66	68
		60 kW	146	166	156	175	164	183	82	86	90	66	69	72
		90 kW	209	238	218	247	227	256	118	123	126	95	98	101
² Maximum Overcurrent Protection (MOCP)	Unit+ Electric Heat and (2) 0.33 HP Power Exhaust	15 kW	125	125	150	150	150	150	60	70	70	50	50	60
		30 kW	125	125	150	150	150	150	60	70	70	50	50	60
		45 kW	⁴ 150	175	175	175	⁴ 175	200	90	90	90	70	70	80
		60 kW	175	175	⁴ 175	200	⁴ 175	200	90	90	100	70	80	80
		90 kW	⁴ 225	250	⁴ 225	⁴ 300	⁴ 250	⁴ 300	125	150	150	100	110	110
³ Minimum Circuit Ampacity (MCA)	Unit+ Electric Heat and (2) 0.33 HP Power Exhaust	15 kW	123	123	131	131	139	139	56	60	64	46	49	52
		30 kW	123	123	131	131	139	139	58	63	66	47	50	53
		45 kW	145	163	154	172	162	180	81	85	89	65	68	71
		60 kW	152	172	162	181	170	189	85	90	93	68	72	74
		90 kW	215	244	224	253	233	262	122	126	130	97	101	103

NOTE - All units have a minimum Short Circuit Current Rating (SCCR) of 5000 amps.

¹ Extremes of operating range are plus and minus 10% of line voltage.

² HACR type breaker or fuse.

³ Refer to National or Canadian Electrical Code manual to determine wire, fuse and disconnect size requirements.

⁴ Factory installed circuit breaker not available.

ELECTRICAL ACCESSORIES - DISCONNECTS

13 TON | LCM156U5

Motor HP	3		5		3	5	3	5
	208V	240V	208V	240V	480V	480V	600V	600V
Unit Only	54W85	54W85	54W85	54W85	54W85	54W85	54W85	54W85
+ Power Exhaust	54W85	54W85	54W86	54W86	54W85	54W85	54W85	54W85
+ Electric Heat 15 kW	54W85	54W85	54W85	54W85	54W85	54W85	54W85	54W85
+ Electric Heat 30 kW	54W86	54W86	54W86	54W86	54W85	54W85	54W85	54W85
+ Electric Heat 45 kW	54W87	54W86	54W87	54W86	54W85	54W85	54W85	54W85
+ Electric Heat 60 kW	54W87	54W87	54W87	54W87	54W86	54W86	54W85	54W85
+ Power Exhaust + Elec. Heat 15 kW	54W85	54W85	54W85	54W85	54W85	54W85	54W85	54W85
+ Power Exhaust + Elec. Heat 30 kW	54W86	54W86	54W86	54W86	54W85	54W85	54W85	54W85
+ Power Exhaust + Elec. Heat 45 kW	54W87	54W86	54W87	54W86	54W85	54W85	54W85	54W85
+ Power Exhaust + Elec. Heat 60 kW	54W87	54W87	54W87	54W87	54W86	54W86	54W85	54W85

15 TON | LCM180U5

Motor HP	3		5		7.5		3	5	7.5	3	5	7.5
	208V	240V	208V	240V	208V	240V	480V	480V	480V	600V	600V	600V
Unit Only	54W85	54W85	54W86	54W86	54W86	54W86	54W85	54W85	54W85	54W85	54W85	54W85
+ Power Exhaust	54W86	54W86	54W86	54W86	54W86	54W86	54W85	54W85	54W85	54W85	54W85	54W85
+ Electric Heat 15 kW	54W85	54W85	54W85	54W85	54W85	54W85	54W85	54W85	54W85	54W85	54W85	54W85
+ Electric Heat 30 kW	54W86	54W86	54W86	54W86	54W86	54W86	54W85	54W85	54W85	54W85	54W85	54W85
+ Electric Heat 45 kW	54W87	54W86	54W87	54W86	54W87	54W87	54W85	54W85	54W85	54W85	54W85	54W85
+ Electric Heat 60 kW	54W87	54W87	54W87	54W87	54W87	54W87	54W86	54W86	54W86	54W85	54W85	54W85
+ Power Exhaust + Elec. Heat 15 kW	54W85	54W85	54W85	54W85	54W86	54W85	54W85	54W85	54W85	54W85	54W85	54W85
+ Power Exhaust + Elec. Heat 30 kW	54W86	54W86	54W86	54W86	54W86	54W86	54W85	54W85	54W85	54W85	54W85	54W85
+ Power Exhaust + Elec. Heat 45 kW	54W87	54W86	54W87	54W86	54W87	54W87	54W85	54W85	54W85	54W85	54W85	54W85
+ Power Exhaust + Elec. Heat 60 kW	54W87	54W87	54W87	54W87	54W87	54W87	54W86	54W86	54W86	54W85	54W85	54W85

17.5 TON | LCM210U5

Motor HP	3		5		7.5		3	5	7.5	3	5	7.5
	208V	240V	208V	240V	208V	240V	480V	480V	480V	600V	600V	600V
Unit Only	54W86	54W86	54W86	54W86	54W86	54W86	54W85	54W85	54W85	54W85	54W85	54W85
+ Power Exhaust	54W86	54W86	54W86	54W86	54W86	54W86	54W85	54W85	54W85	54W85	54W85	54W85
+ Electric Heat 15 kW	54W85	54W85	54W85	54W85	54W85	54W85	54W85	54W85	54W85	54W85	54W85	54W85
+ Electric Heat 30 kW	54W86	54W86	54W86	54W86	54W86	54W86	54W85	54W85	54W85	54W85	54W85	54W85
+ Electric Heat 45 kW	54W87	54W86	54W87	54W86	54W87	54W87	54W85	54W85	54W85	54W85	54W85	54W85
+ Electric Heat 60 kW	54W87	54W87	54W87	54W87	54W87	54W87	54W86	54W86	54W86	54W85	54W85	54W85
+ Electric Heat 90 kW	¹ NA	¹ NA	¹ NA	¹ NA	¹ NA	¹ NA	54W86	54W86	54W86	54W86	54W86	54W86
+ Power Exhaust + Elec. Heat 15 kW	54W85	54W85	54W85	54W85	54W86	54W85	54W85	54W85	54W85	54W85	54W85	54W85
+ Power Exhaust + Elec. Heat 30 kW	54W86	54W86	54W86	54W86	54W86	54W86	54W85	54W85	54W85	54W85	54W85	54W85
+ Power Exhaust + Elec. Heat 45 kW	54W87	54W86	54W87	54W86	54W87	54W87	54W85	54W85	54W85	54W85	54W85	54W85
+ Power Exhaust + Elec. Heat 60 kW	54W87	54W87	54W87	54W87	54W87	54W87	54W86	54W86	54W86	54W85	54W85	54W85
+ Power Exhaust + Elec. Heat 90 kW	¹ NA	¹ NA	¹ NA	¹ NA	¹ NA	¹ NA	54W86	54W86	54W86	54W86	54W86	54W86

Disconnects - 54W85 - 80A
 54W86 - 150A
 54W87 - 250A

¹ Disconnect must be field furnished.

ELECTRICAL ACCESSORIES - DISCONNECTS

20 TON | LCM240U5

Motor HP Electric Heat Voltage	5		7.5		10		5	7.5	10	5	7.5	10
	208V	240V	208V	240V	208V	240V	480V	480V	480V	600V	600V	600V
Unit Only	54W86	54W86	54W86	54W86	54W86	54W86	54W85	54W85	54W85	54W85	54W85	54W85
+ Power Exhaust	54W86	54W86	54W86	54W86	54W86	54W86	54W85	54W85	54W85	54W85	54W85	54W85
+ Electric Heat 15 kW	54W85	54W85	54W85	54W85	54W86	54W85	54W85	54W85	54W85	54W85	54W85	54W85
+ Electric Heat 30 kW	54W86	54W86	54W86	54W86	54W86	54W86	54W85	54W85	54W85	54W85	54W85	54W85
+ Electric Heat 45 kW	54W87	54W86	54W87	54W87	54W87	54W87	54W85	54W85	54W85	54W85	54W85	54W85
+ Electric Heat 60 kW	54W87	54W87	54W87	54W87	54W87	54W87	54W86	54W86	54W86	54W85	54W85	54W85
+ Electric Heat 90 kW	¹ NA	¹ NA	¹ NA	¹ NA	¹ NA	¹ NA	54W86	54W86	54W86	54W86	54W86	54W86
+ Power Exhaust + Elec. Heat 15 kW	54W85	54W85	54W86	54W85	54W86	54W86	54W85	54W85	54W85	54W85	54W85	54W85
+ Power Exhaust + Elec. Heat 30 kW	54W86	54W86	54W86	54W86	54W86	54W86	54W85	54W85	54W85	54W85	54W85	54W85
+ Power Exhaust + Elec. Heat 45 kW	54W87	54W86	54W87	54W87	54W87	54W87	54W85	54W85	54W86	54W85	54W85	54W85
+ Power Exhaust + Elec. Heat 60 kW	54W87	54W87	54W87	54W87	54W87	54W87	54W86	54W86	54W86	54W85	54W85	54W86
+ Power Exhaust + Elec. Heat 90 kW	¹ NA	¹ NA	¹ NA	¹ NA	¹ NA	¹ NA	54W86	54W86	54W86	54W86	54W86	54W86

25 TON | LCM300U5

Motor HP Electric Heat Voltage	5		7.5		10		5	7.5	10	5	7.5	10
	208V	240V	208V	240V	208V	240V	480V	480V	480V	600V	600V	600V
Unit Only	54W86	54W86	54W86	54W86	54W86	54W86	54W85	54W85	54W85	54W85	54W85	54W85
+ Power Exhaust	54W86	54W86	54W86	54W86	54W87	54W87	54W85	54W85	54W85	54W85	54W85	54W85
+ Electric Heat 15 kW	54W85	54W85	54W85	54W85	54W86	54W85	54W85	54W85	54W85	54W85	54W85	54W85
+ Electric Heat 30 kW	54W86	54W86	54W86	54W86	54W86	54W86	54W85	54W85	54W85	54W85	54W85	54W85
+ Electric Heat 45 kW	54W87	54W86	54W87	54W87	54W87	54W87	54W85	54W85	54W85	54W85	54W85	54W85
+ Electric Heat 60 kW	54W87	54W87	54W87	54W87	54W87	54W87	54W86	54W86	54W86	54W85	54W85	54W85
+ Electric Heat 90 kW	¹ NA	¹ NA	¹ NA	¹ NA	¹ NA	¹ NA	54W86	54W86	54W86	54W86	54W86	54W86
+ Power Exhaust + Elec. Heat 15 kW	54W85	54W85	54W86	54W85	54W86	54W86	54W85	54W85	54W85	54W85	54W85	54W85
+ Power Exhaust + Elec. Heat 30 kW	54W86	54W86	54W86	54W86	54W86	54W86	54W85	54W85	54W85	54W85	54W85	54W85
+ Power Exhaust + Elec. Heat 45 kW	54W87	54W86	54W87	54W87	54W87	54W87	54W85	54W85	54W86	54W85	54W85	54W85
+ Power Exhaust + Elec. Heat 60 kW	54W87	54W87	54W87	54W87	54W87	54W87	54W86	54W86	54W86	54W85	54W85	54W86
+ Power Exhaust + Elec. Heat 90 kW	¹ NA	¹ NA	¹ NA	¹ NA	¹ NA	¹ NA	54W86	54W86	54W86	54W86	54W86	54W86

Disconnects - 54W85 - 80A
 54W86 - 150A
 54W87 - 250A

¹ Disconnect must be field furnished.

FIELD WIRING NOTES

- For use with copper wiring only
- Field wiring not furnished
- All wiring must conform to NEC or CEC and local electrical codes
- For specific wiring information, please refer to the installation instructions

ELECTRIC HEAT CAPACITIES

Volts Input	15 kW			30 kW			45 kW			60 kW			90 kW		
	kW Input	Btuh Output	Stages	kW Input	Btuh Output	Stages	kW Input	Btuh Output	Stages	kW Input	Btuh Output	Stages	kW Input	Btuh Output	Stages
208	11.3	38,600	1	22.5	76,800	1	33.8	115,300	2	45.0	153,600	2	67.6	230,700	2
220	12.6	43,000	1	25.2	86,000	1	37.8	129,000	2	50.4	172,000	2	75.6	258,000	2
230	13.8	47,100	1	27.5	93,900	1	41.3	141,000	2	55.1	188,000	2	82.7	282,200	2
240	15.0	51,200	1	30.0	102,400	1	45.0	153,600	2	60.0	204,800	2	90.0	307,100	2
440	12.6	43,000	1	25.2	86,000	1	37.8	129,000	2	50.4	172,000	2	75.6	258,000	2
460	13.8	47,100	1	27.5	93,900	1	41.3	141,000	2	55.1	188,000	2	82.7	282,200	2
480	15.0	51,200	1	30.0	102,400	1	45.0	153,600	2	60.0	204,800	2	90.0	307,100	2
550	12.6	43,000	1	25.2	86,000	1	37.8	129,000	2	50.4	172,000	2	75.6	258,000	2
575	13.8	47,100	1	27.5	93,900	1	41.3	141,000	2	55.1	188,000	2	82.7	282,200	2
600	15.0	51,200	1	30.0	102,400	1	45.0	153,600	2	60.0	204,800	2	90.0	307,100	2

UNIT CLEARANCES

Unit With Economizer

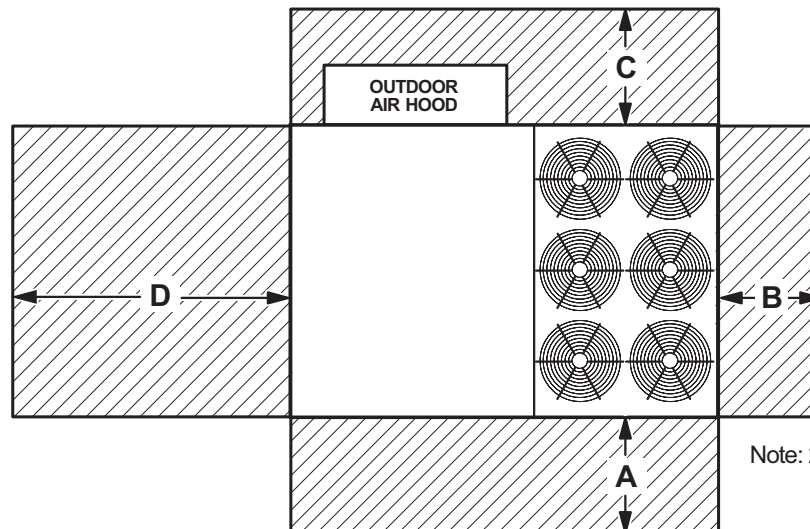

Note: 210-240-300 sizes shown

¹ Unit Clearance	A		B		C		D		Top Clearance
	in.	mm	in.	mm	in.	mm	in.	mm	
Service Clearance	60	1524	36	914	36	934	66	1676	Unobstructed
Clearance to Combustibles	36	914	1	25	1	25	1	25	
Minimum Operation Clearance	45	1143	36	914	36	914	41	1041	

NOTE - Entire perimeter of unit base requires support when elevated above the mounting surface.

¹ Service Clearance - Required for removal of serviceable parts.

Clearance to Combustibles - Required clearance to combustible material.

Minimum Operation Clearance - Required clearance for proper unit operation.

OUTDOOR SOUND DATA

Size	Octave Band Sound Power Levels dBA, re 10 ⁻¹² Watts - Center Frequency - Hz							¹ Sound Rating Number (dBA)
	125	250	500	1000	2000	4000	8000	
156, 180	71	76	80	78	74	70	63	86
210, 240, 300	73	81	86	84	78	73	67	90

Note - The octave sound power data does not include tonal corrections.

¹ Sound Rating Number according to AHRI Standard 370-2001 (includes pure tone penalty).

Sound Rating Number is the overall A-Weighted Sound Power Level (LWA), dBA (100 Hz to 10,000 Hz).

WEIGHT DATA				UNIT
Size	Net		Shipping	
	lbs.	kg	lbs.	kg
156 Base Unit	2051	930	2251	1021
156 Max. Unit	2336	1060	2536	1150
180 Base Unit	2054	932	2254	1022
180 Max. Unit	2339	1061	2539	1152
210 Base Unit	2499	1133	2698	1224
210 Max. Unit	2784	1262	2983	1353
240 Base Unit	2525	1145	2725	1236
240 Max. Unit	2810	1274	3010	1365
300 Base Unit	2566	1164	2766	1254
300 Max. Unit	2851	1293	3051	1384

NOTE - Max. Unit is the unit with ALL INTERNAL OPTIONS Installed. (Economizer, Standard Static Power Exhaust Fans, Controls, etc.). Does not include accessories EXTERNAL to unit.

FACTORY / FIELD INSTALLED OPTIONS AND ACCESSORIES - NET WEIGHTS			
Description	lbs.	kg	
ECONOMIZER / OUTDOOR AIR / EXHAUST			
Economizer			
Economizer Dampers (with Outdoor Air Hood)	167	76	
Barometric Relief Dampers (downflow)	30	14	
Barometric Relief Dampers (horizontal)	20	9	
Outdoor Air Dampers			
Outdoor Air Damper Section (downflow) - Automatic (including Hood)	39	18	
Outdoor Air Damper Section (downflow) - Manual (including Hood)	22	10	
Power Exhaust	62	28	
ELECTRIC HEAT			
15 kW	59	27	
30 kW	59	27	
45 kW	76	34	
60 kW	76	34	
90 kW	84	38	
COMBINATION COIL/HAIL GUARDS			
All Models	36	16	
ROOF CURBS			
Hybrid Roof Curbs, Downflow			
8 in. height	136	62	
14 in. height	169	77	
18 in. height	191	87	
24 in. height	224	102	
Adjustable Pitch Curb, Downflow			
14 in. height	224	102	
Horizontal, Standard			
26 in. height	450	204	
37 in. height	540	245	
30 in. height	495	225	
41 in. height	575	261	
CEILING DIFFUSERS			
Step-Down	RTD11-185S	168	76
	RTD11-275S	238	108
Flush	FD11-185S	168	76
	FD11-275S	238	108
Transitions	C1DIFF33C-1	80	36
	C1DIFF34C-1	75	34
HUMIDITROL™+ HOT GAS REHEAT SYSTEM			
Humiditrol®+ Dehumidification Option	50	23	

DIMENSIONS

LCM156 | LCM180

CORNER WEIGHTS

CENTER OF GRAVITY

Model	AA		BB		CC		DD		EE		FF	
	lbs.	kg	lbs.	kg	lbs.	kg	lbs.	kg	in.	mm	in.	mm
LCM156 Base Unit	446	203	416	189	573	261	615	279	52	1321	38-3/8	974
LCM156 Max. Unit	552	251	499	227	610	277	674	306	51-1/4	1300	41	1042
LCM180 Base Unit	447	203	416	189	574	261	616	280	52	1320	38-1/4	973
LCM180 Max. Unit	552	251	499	227	611	278	676	307	51-1/8	1300	41	1041

Base Unit - The unit with NO INTERNAL OPTIONS.

Max. Unit - The unit with ALL INTERNAL OPTIONS Installed. (Economizer, Standard Static Power Exhaust Fans, Controls, etc.). Does not include accessories external to unit.

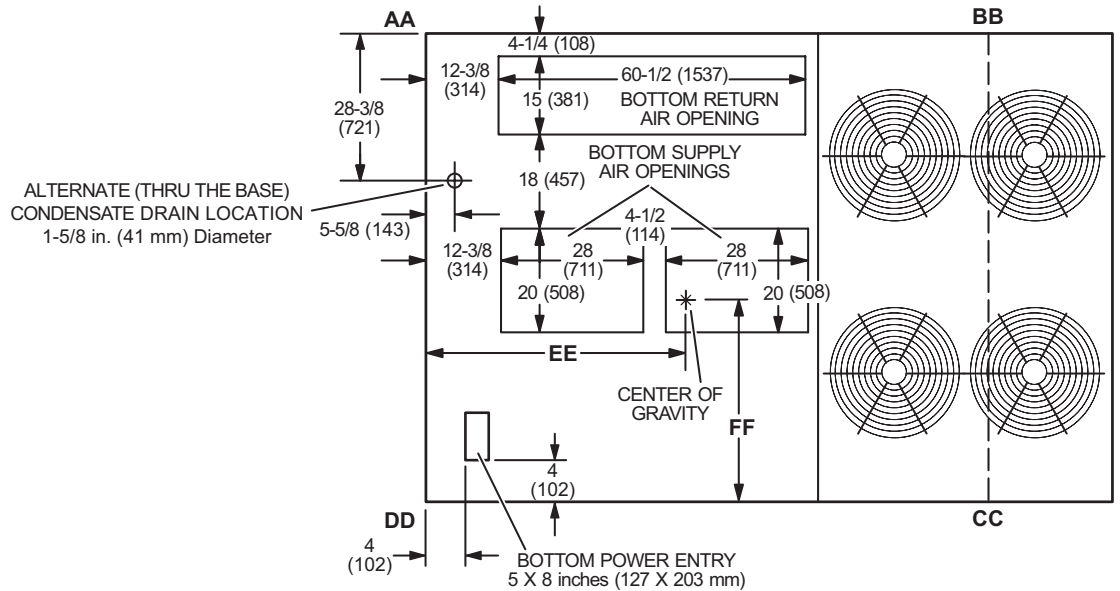

TOP VIEW

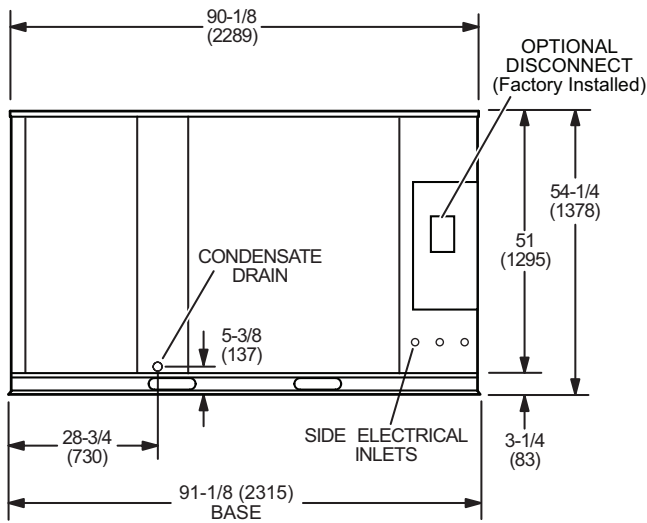

END VIEW

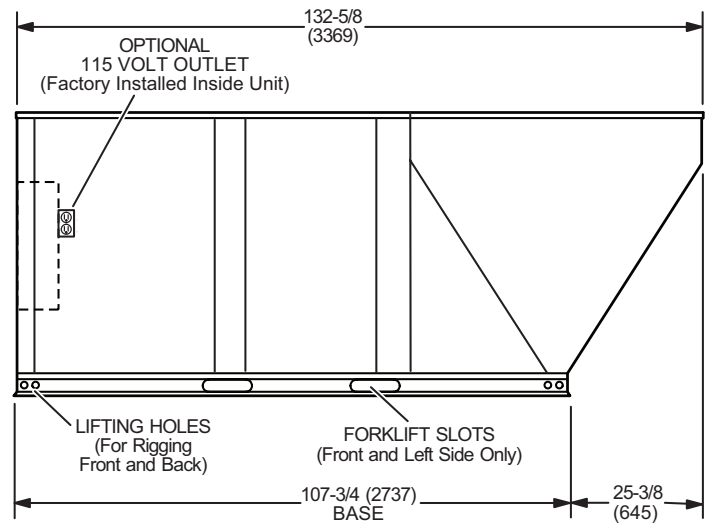

SIDE VIEW

DIMENSIONS

LCM210 | LCM240 | LCM300

CORNER WEIGHTS

CENTER OF GRAVITY

Model	AA		BB		CC		DD		EE		FF	
	lbs.	kg	lbs.	kg	lbs.	kg	lbs.	kg	in.	mm	in.	mm
LCM210 Base Unit	478	217	600	273	790	359	629	286	60	1523	39 1/3	999
LCM210 Max. Unit	582	265	693	315	819	372	688	313	58-1/2	1487	41-3/4	1061
LCM240 Base Unit	481	219	594	270	800	364	648	295	59-1/2	1512	38-7/8	986
LCM240 Max. Unit	586	266	686	312	830	377	709	322	58-1/8	1476	41-1/4	1047
LCM300 Base Unit	486	221	580	264	816	371	684	311	58-5/8	1489	37-7/8	961
LCM300 Max. Unit	591	269	672	305	845	384	743	338	57-3/8	1456	40-3/8	1025

Base Unit - The unit with NO INTERNAL OPTIONS.

Max. Unit - The unit with ALL INTERNAL OPTIONS Installed. (Economizer, Standard Static Power Exhaust Fans, Controls, etc.). Does not include accessories external to unit.

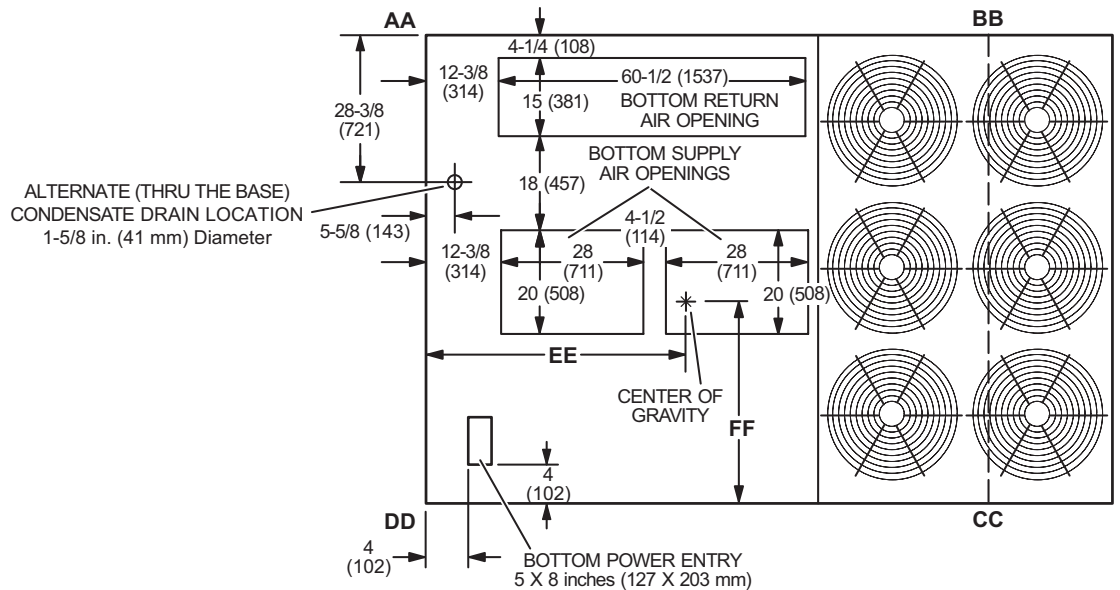

TOP VIEW

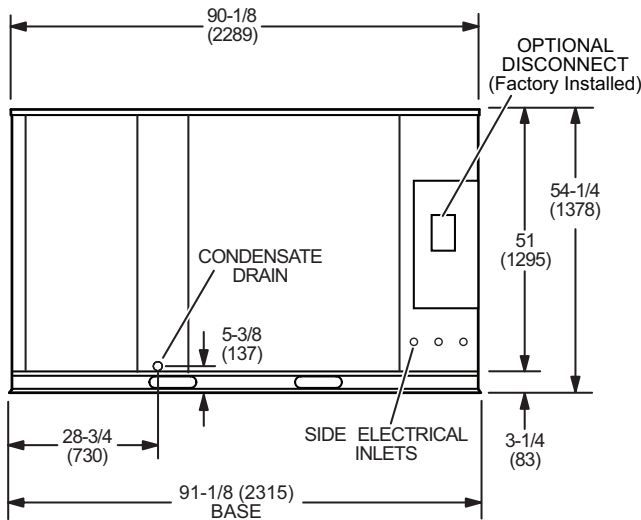

END VIEW

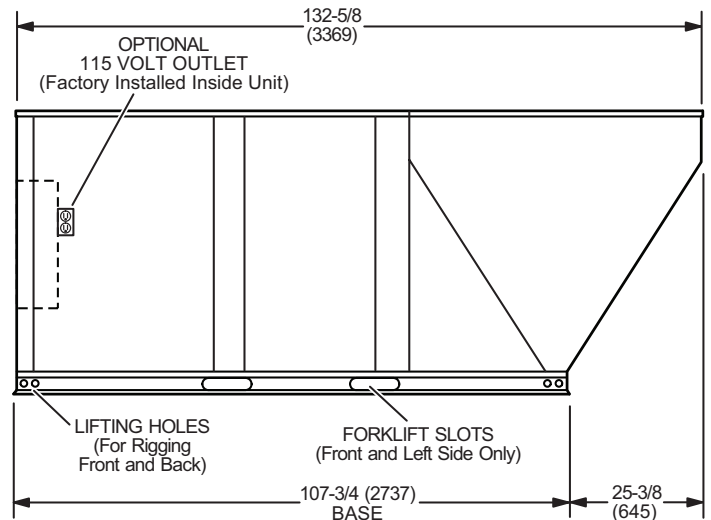

SIDE VIEW

OUTDOOR AIR HOOD DETAIL

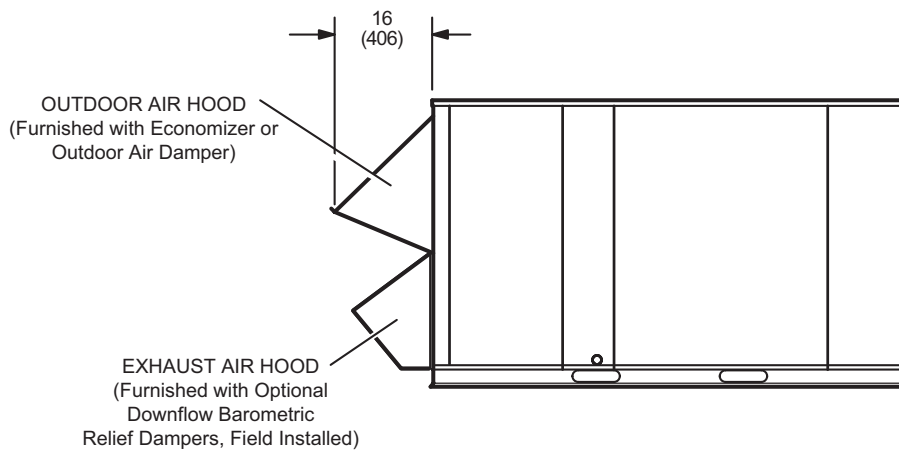

OPTIONAL HORIZONTAL BAROMETRIC RELIEF DAMPERS WITH HOOD
(Field installed in horizontal return air duct adjacent to unit)

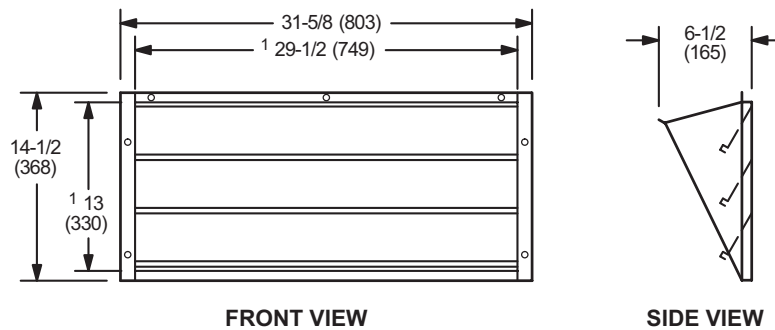

NOTE - Two furnished per order no.
¹ NOTE - Opening size required in return air duct.

HYBRID ROOF CURBS - DOUBLE DUCT OPENING

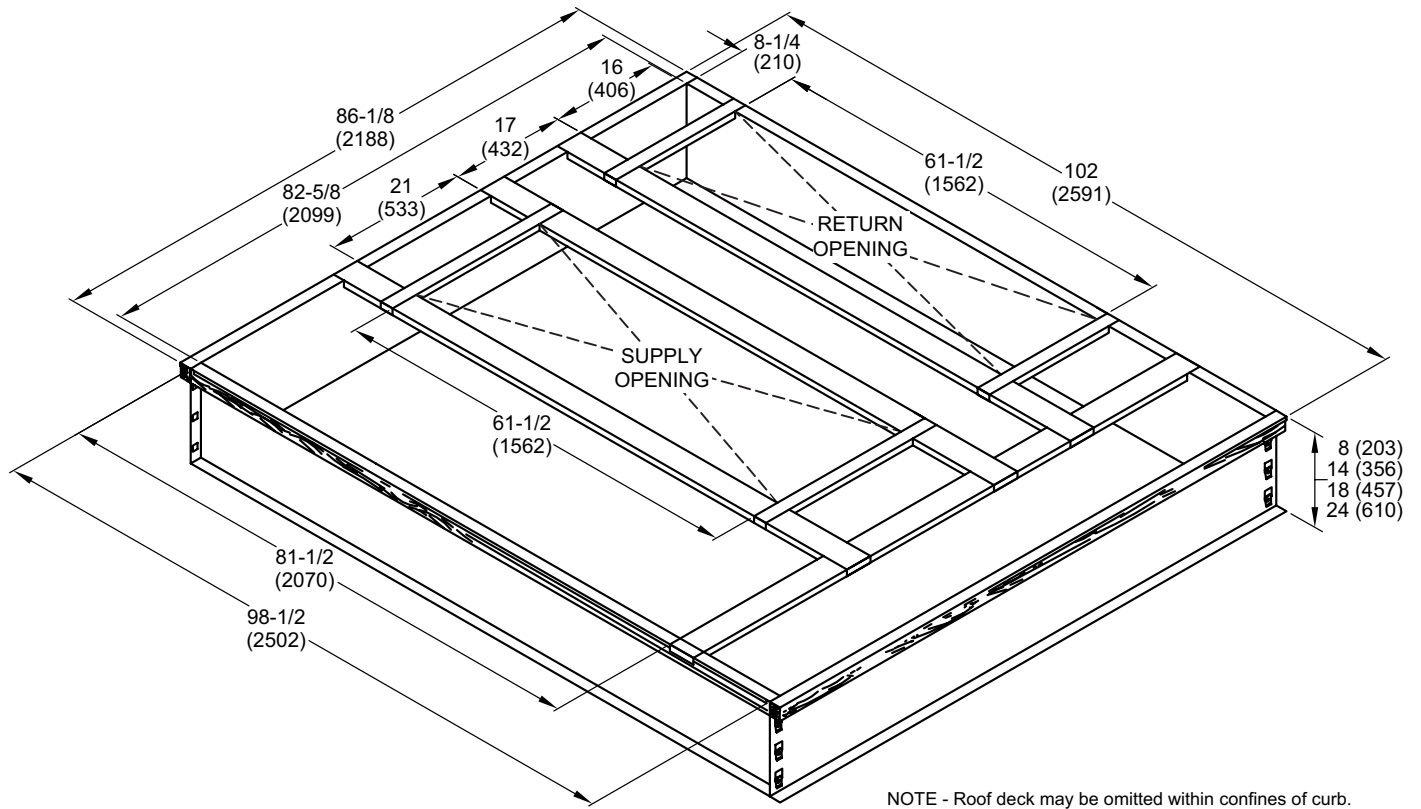

TYPICAL FLASHING DETAIL FOR ROOF CURB

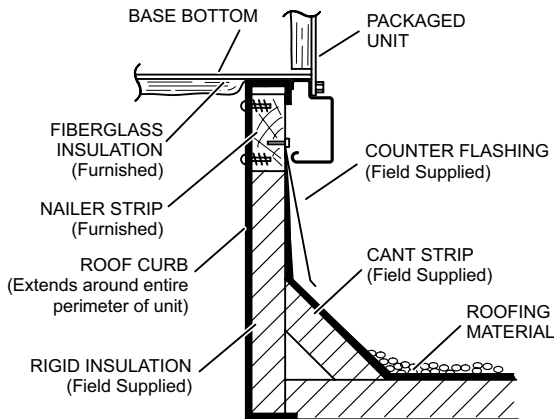

DETAIL ROOF CURB

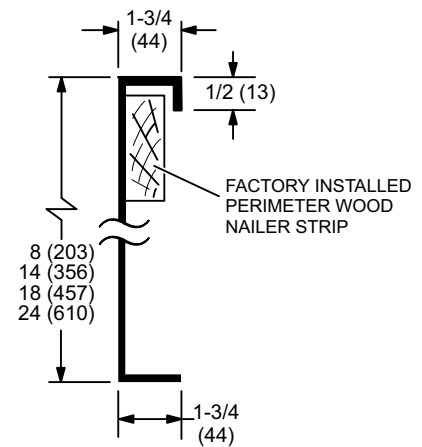

ADJUSTABLE PITCH CURB - DOUBLE DUCT OPENING

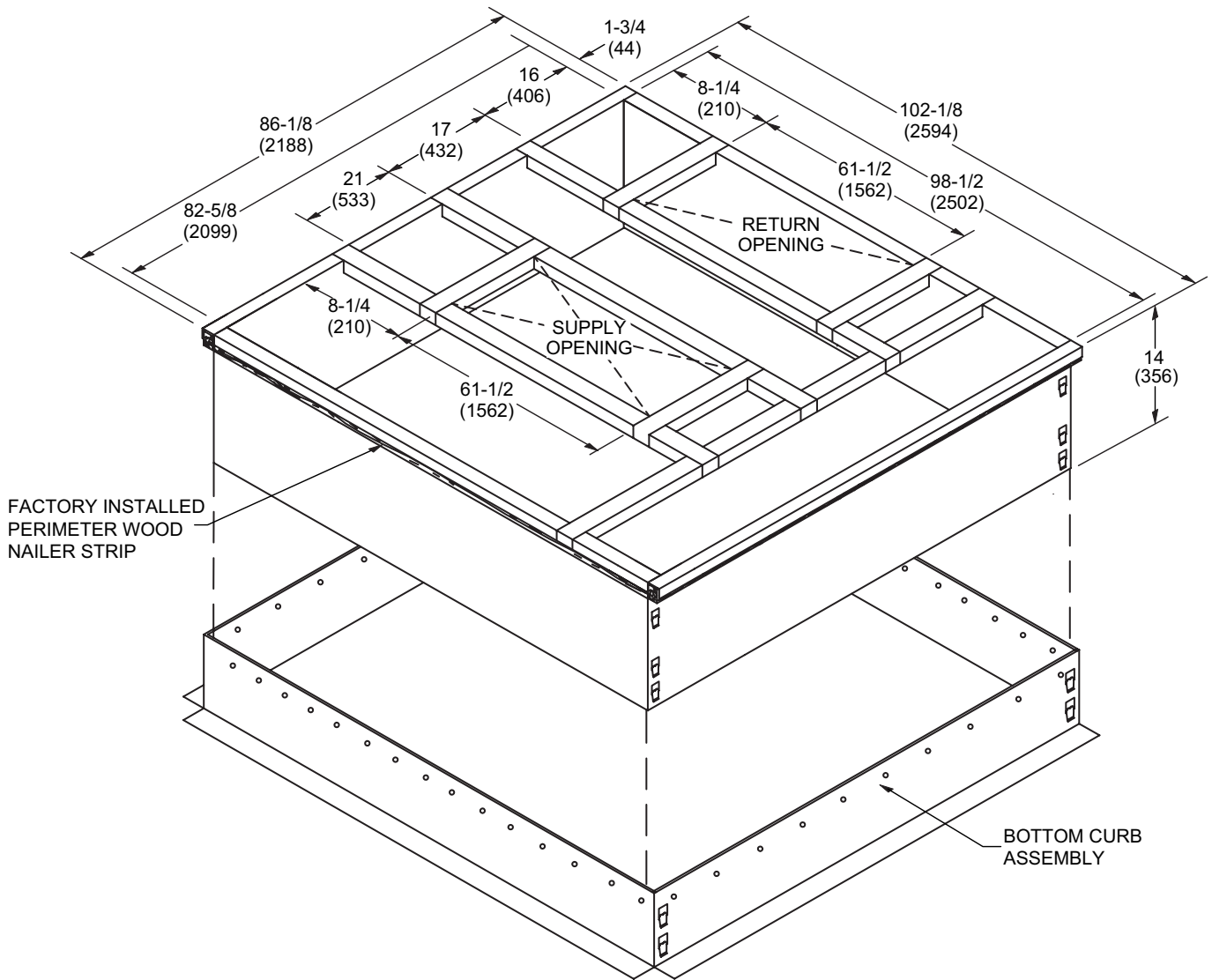

NOTE - Maximum slope pitch is 3/4 in. per 1 foot (19 mm per 305 mm) in any one direction.

TYPICAL FLASHING DETAIL FOR ROOF CURB

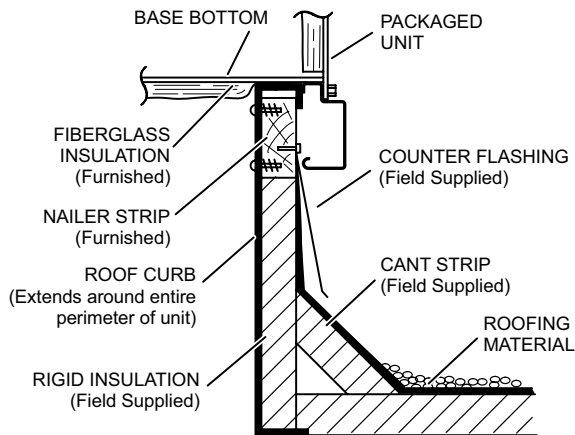

DETAIL ROOF CURB

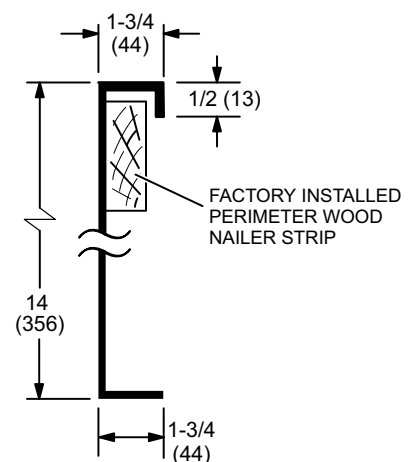

ROOF CURBS WITH SUPPLY & RETURN AIR TRANSITIONS FOR CEILING DIFFUSERS

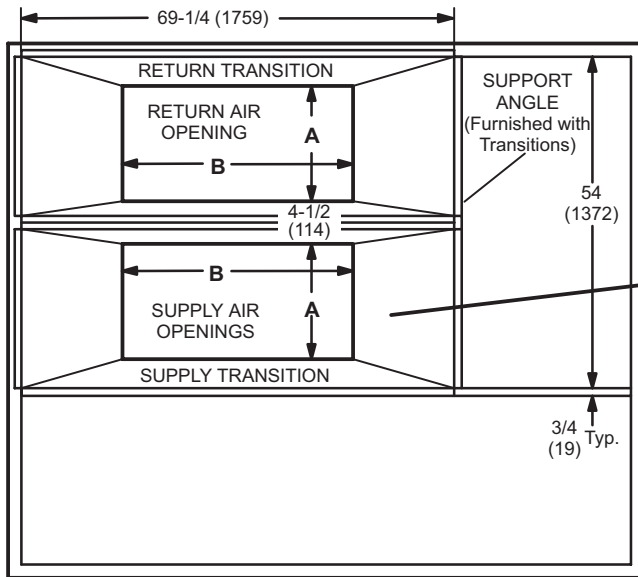

TOP VIEW

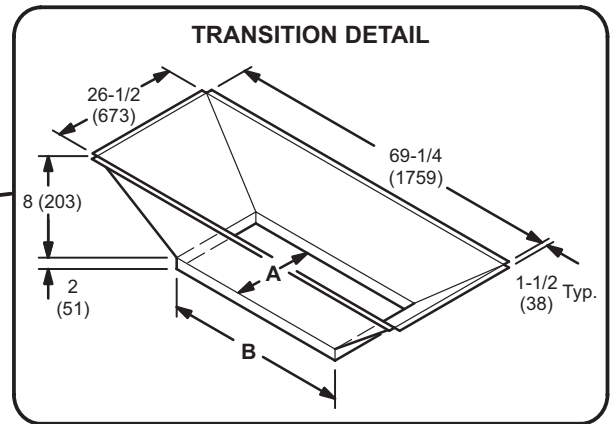

TRANSITION OPENING SIZES

Model Number	A		B	
	inch	mm	inch	mm
C1DIFF33C-1	18	457	36	914
C1DIFF34C-1	24	610	48	1219

HORIZONTAL ROOF CURBS – Requires Optional Horizontal Return Air Panel Kit

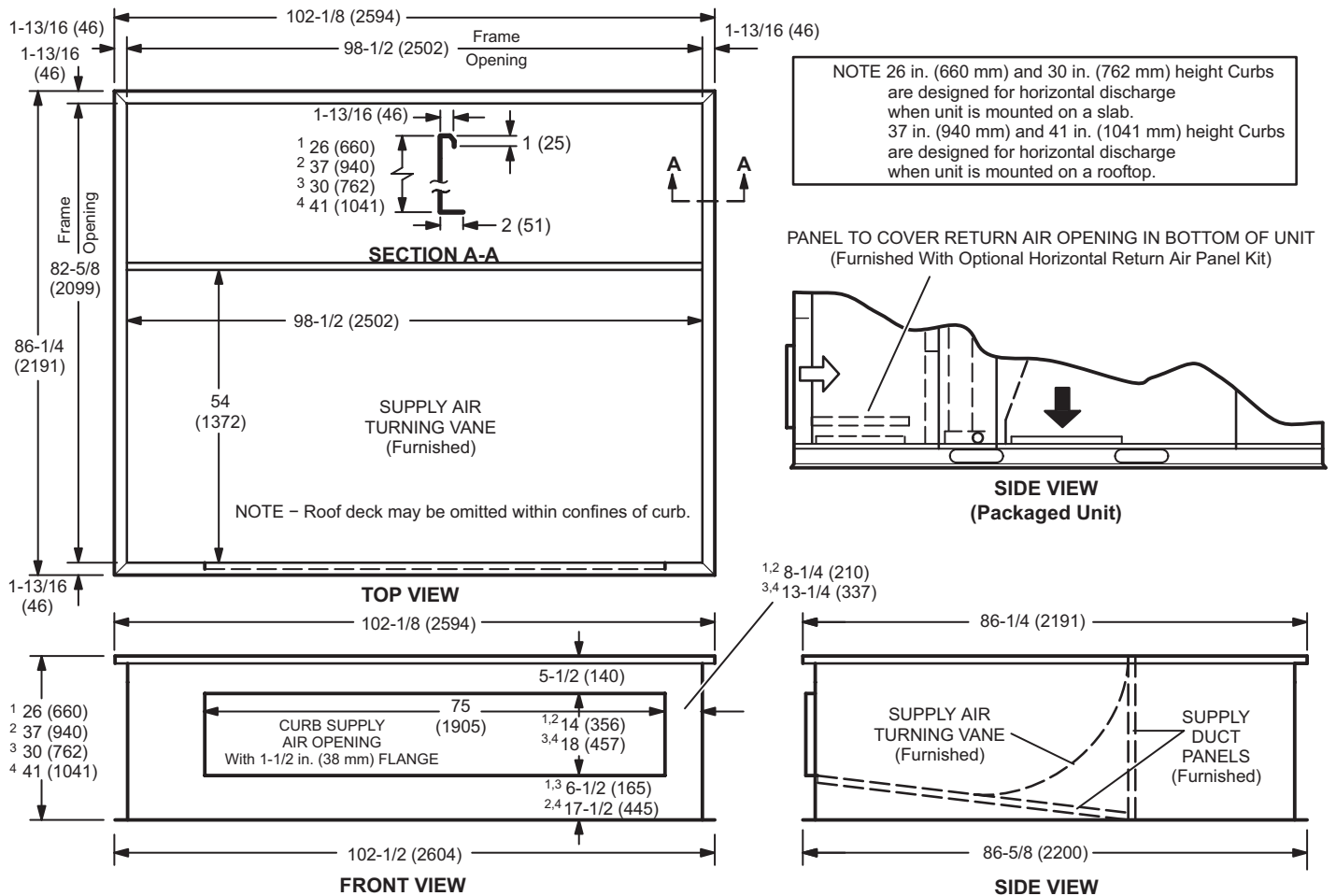

¹ Slab Applications ² Rooftop Applications ³ Slab Applications (used with 300 only) ⁴ Rooftop Applications (used with 300 only)

HORIZONTAL SUPPLY AND RETURN AIR OPENINGS WITH HORIZONTAL ROOF CURB

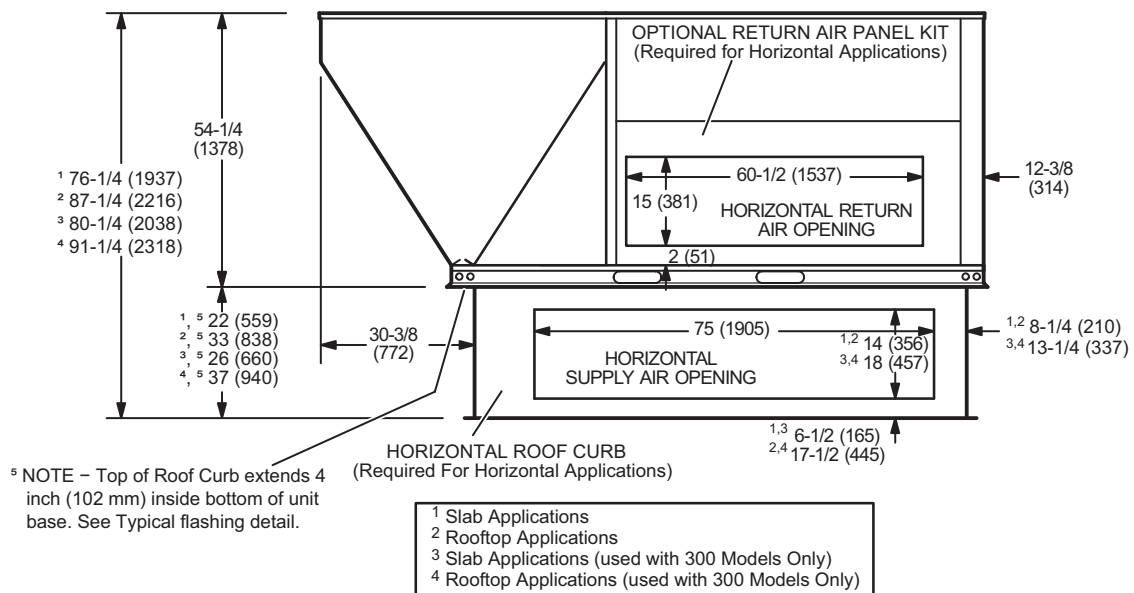

COMBINATION CEILING SUPPLY AND RETURN DIFFUSERS

STEP-DOWN CEILING DIFFUSER

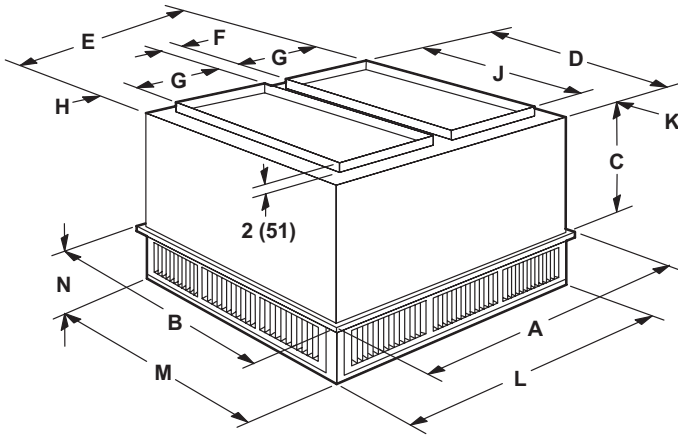

FLUSH CEILING DIFFUSER

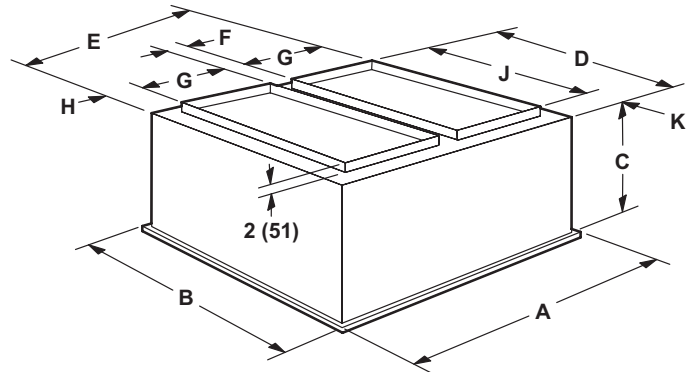

Model		RTD11-185S	RTD11-275S
A	in.	47-5/8	59-5/8
	mm	1210	1514
B	in.	47-5/8	59-5/8
	mm	1210	1514
C	in.	24-5/8	30-5/8
	mm	625	778
D	in.	45-1/2	57-1/2
	mm	1156	1461
E	in.	45-1/2	57-1/2
	mm	1156	1461
F	in.	4-1/2	4-1/2
	mm	114	114
G	in.	18	24
	mm	457	610
H	in.	2-1/2	2-1/2
	mm	64	64
J	in.	36	48
	mm	914	1219
K	in.	4-3/4	4-3/4
	mm	121	121
L	in.	45-1/2	57-1/2
	mm	1156	1461
M	in.	45-1/2	57-1/2
	mm	1156	1461
N	in.	10-1/8	11-1/8
	mm	257	283
Duct Size	in.	18 x 36	24 x 48
	mm	457 x 914	610 x 1219

Model		FD11-185S	FD11-275S
A	in.	47-5/8	59-5/8
	mm	1210	1514
B	in.	47-5/8	59-5/8
	mm	1210	1514
C	in.	29-1/4	35-1/4
	mm	743	895
D	in.	45	57
	mm	1143	1148
E	in.	45	57
	mm	1143	1448
F	in.	4-1/2	4-1/2
	mm	114	114
G	in.	18	24
	mm	457	610
H	in.	2-1/4	2-1/4
	mm	57	57
J	in.	36	48
	mm	914	1219
K	in.	4-1/2	4-1/2
	mm	114	114
Duct Size	in.	18 x 36	24 x 48
	mm	457 x 914	610 x 1219

REVISIONS

Sections	Description of Change
Options / Accessories	Added Burglar Bars.



Visit us at www.Lennox.com

For the latest technical information, www.LennoxCommercial.com

Contact us at 1-800-4-LENNOX

NOTE - Due to Lennox' ongoing commitment to quality, Specifications, Ratings and Dimensions subject to change without notice and without incurring liability. Improper installation, adjustment, alteration, service or maintenance can cause property damage or personal injury. Installation and service must be performed by a qualified installer and servicing agency.

©2025 Lennox Industries, Inc.