



PRODUCT SPECIFICATIONS

Bulletin No. 210504
September 2014
Supersedes July 2014



**ASHRAE 90.1
COMPLIANT**

2 to 7.5 Tons
Net Cooling Capacity - 23,600 to 90,000 Btuh
Optional Electric Heat - 7.5 to 30 kW

MODEL NUMBER IDENTIFICATION

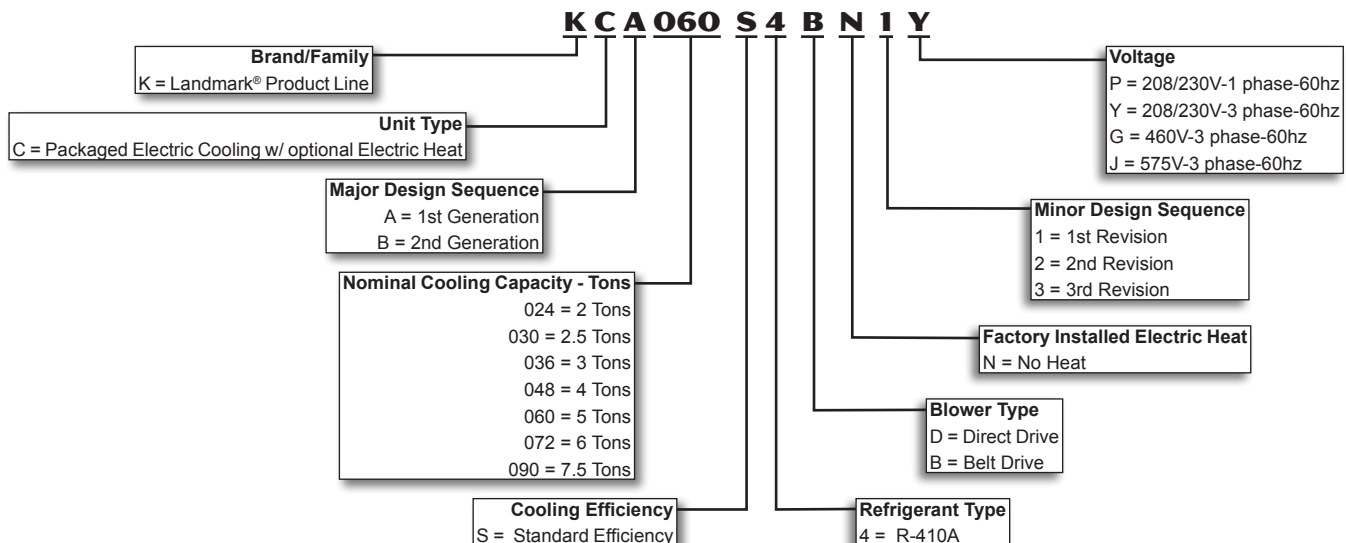

FEATURES AND BENEFITS

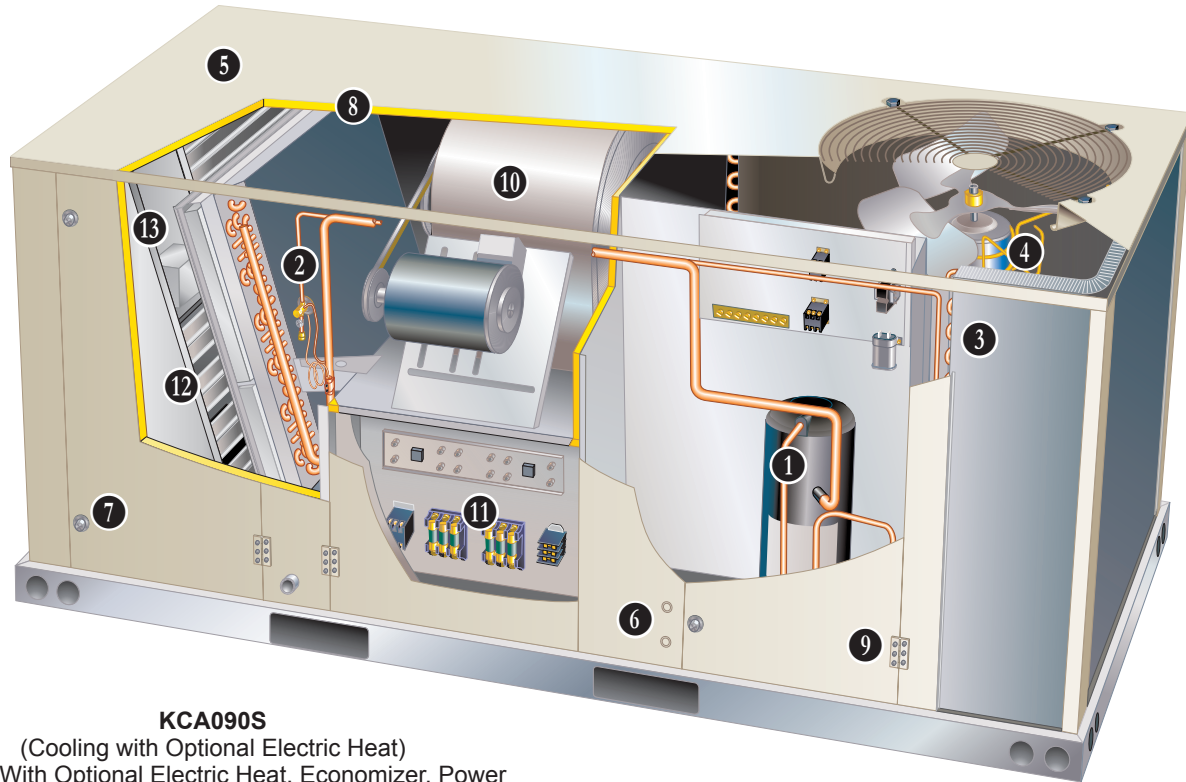

KCA090S

(Cooling with Optional Electric Heat)
Shown With Optional Electric Heat, Economizer, Power
Exhaust and Hinged Access Panels

Landmark® rooftop units from Lennox are the new standard for reliable, efficient rooftop units built for long-lasting performance that can significantly improve indoor environments. Landmark® rooftop units feature:

- **R-410A Refrigerant** - Environmentally friendly.
- **Scroll Compressors** - Single speed scroll compressors are furnished on all models.
- **Lennox' Environ™ Coil System (090 Models Only)** - Smaller, lighter condenser coil.
- **High Pressure Switches** - Protect compressor.
- **Isolated Compressor Compartment** - Allows performance check during normal compressor operation without disrupting airflow.
- **Direct or Belt Drive Blower Motors** - Direct drive (024, 030, 036, 048 and 060 models). Belt drive motors (036, 048, 060, 072 and 090 models) to maximize air performance.
- **Independent Motor Mounts** - Allows for easy and efficient service access without removing the top panel.
- **Downflow or Horizontal Airflow** - Easy field conversion.
- **Two Fork Lift Slots on Three Sides** - Easy to pick up and transport units from almost any angle.
- **Corrosion-Resistant Removable, Reversible Drain Pan** - Provides application flexibility, durability and improved serviceability.
- **Thermostatic Expansion Valves (024, 036, 048, 060 and 072 models)** - Provide peak cooling performance across the entire application range.
- **Common Components** - Many maintenance items are standard throughout the entire product line, reducing the need to carry different parts to the job or maintain in inventory.

FEATURES AND BENEFITS

CONTENTS

Accessory Dimensions40
Blower Data - Belt Drive21
Blower Data - Direct Drive18
Dimensions39
Electrical/Electric Heat Data30
Electric Heat Capacities36
Features And Benefits	2
Model Number Identification	1
Optional Conventional Temperature Control Systems37
Options / Accessories	9
Outdoor Sound Data37
Ratings16
Specifications - Belt Drive Blower15
Specifications - Direct Drive Blower.13
Unit Clearances36
Weight Data38

APPROVALS

AHRI Certified to AHRI Standard 210/240-2008 (2 - 5 ton models) and AHRI Standard 340/360-2007 (6 and 7.5 ton models).

ETL listed.

CSA listed.

Components bonded for grounding to meet safety standards for servicing required by UL, ULC and National and Canadian Electrical Codes.

All models are ASHRAE 90.1 compliant.

ISO 9001 Registered Manufacturing Quality System.

WARRANTY

Limited five years on compressors.

Limited three years on the Lennox' Environ™ Coil System.

Limited five years Optional High Performance Economizers.

Limited one year all other covered components.

COOLING SYSTEM

Designed to maximize sensible and latent cooling performance at design conditions.

System can operate from 30°F to 125°F without any additional controls.

R-410A Refrigerant

Non-chlorine, ozone friendly, R-410A.



Unit is factory pre-charged with refrigerant. See Specifications Tables.

1 Compressor

Resiliently mounted on rubber grommets for quiet operation.

Scroll compressors for high performance, reliability and quiet operation.

Compressor Crankcase Heater (Furnished on 072 Models Only)

Protects against refrigerant migration that can occur during low ambient operation.

2 Thermal Expansion Valve (024 thru 072 Models)

Assures optimal performance throughout the application range.

Removable element head.

Refrigerant Metering Orifice (090 Models)

Accurately meters refrigerant in system.

Refrigerant control is accomplished by exact sizing of refrigerant metering orifice.

High Pressure Switch

Protects the compressor from overload conditions such as dirty condenser coils, blocked refrigerant flow, or loss of outdoor fan operation.

Filter/Drier

High capacity filter/drier protects the system from dirt and moisture.

Freezestat

Protects the evaporator coil from damaging ice build-up due to conditions such as low/no air flow, or low refrigerant charge.

3 Lennox' Environ™ Coil System (090 Models Only)

Condenser coil features lightweight, all aluminum brazed fin construction.

Constructed of three components: a flat extrusion

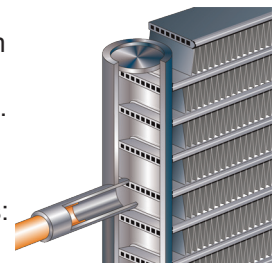

tube, fins in-between the flat extrusion tube and two refrigerant manifolds.

Environ™ Coil System Features:

- Improved heat transfer performance due to high primary surface area (flat tubes) versus secondary surface (fins).
- Smaller internal volume (reduced refrigerant charge).
- High durability (all aluminum construction).
- Fewer brazed joints.
- Compact design (reduces unit weight).
- Easy maintenance/cleaning.

FEATURES AND BENEFITS

COOLING SYSTEM

(continued)

Mounting brackets with rubber inserts secure coil to unit providing vibration dampening and corrosion protection.

Conventional Fin/Tube Coil (Condenser Coil for 024 thru 072 Models) and Evaporator Coil (all models)

Copper tube construction, enhanced rippled-edge aluminum fins, flared shoulder tubing connections, silver soldered construction for improved heat transfer. Factory leak tested. Cross row circuiting with rifled tubing optimizes both sensible and latent cooling capacity.

Condensate Drain Pan

Plastic pan, sloped to meet drainage requirements of ASHRAE 62.1.

Side or bottom drain connections. Reversible to allow connection at back of unit.

4 Outdoor Coil Fan Motor

Thermal overload protected, totally enclosed, permanently lubricated sleeve (024, 030, 036 and 048 models) or ball bearings (060, 072 and 090 models), shaft up, wire basket mount.

Outdoor Coil Fan

PVC coated fan guard furnished.

Required Selections

Cooling Capacity

Specify nominal cooling capacity of the unit.

Options/Accessories

Field Installed

Condensate Drain Trap

Field installed only.

Available in copper or PVC.

Compressor Crankcase Heater (Optional for 024 thru 060 and 090 Models Only)

Protects against refrigerant migration that can occur during low ambient operation.

Drain Pan Overflow Switch

Monitors condensate level in drain pan, shuts down unit if drain becomes clogged.

Low Ambient Kit

Cycles the outdoor fan while allowing compressor operation in the cooling cycle. This intermittent fan operation allows the system to operate without icing the evaporator coil and losing capacity. Designed for use in ambient temperatures no lower than 0°F. A crankcase heater must be installed on the compressor.

CABINET

5 Construction

Heavy-gauge steel panels and full perimeter heavy-gauge galvanized steel base rail provides structural integrity for transportation, handling, and installation.

Base rails have rigging holes. Three sides of the base rail have fork slots.

Raised edges around duct and power entry openings in the bottom of the unit provide additional protection against water entering the building.

Airflow Choice

Units are shipped in downflow (vertical) configuration, can be field converted to horizontal air flow configuration without the need of a kit.

6 Power Entry

Electrical lines can be brought through the unit base or through horizontal access knock-outs.

7 Exterior Panels

Constructed of heavy-gauge, galvanized steel with a two-layer enamel paint finish.

8 Insulation

All panels adjacent to conditioned air are fully insulated with non-hygroscopic fiberglass insulation.

Unit base is fully insulated. The insulation also serves as an air seal to the roof curb, eliminating the need to add a seal during installation.

Access Panels

Access panels are provided for the economizer/filter section, heating/blower section, and the compressor/controls section.

NOTE - Optional Economizers, Power Exhaust, Outdoor Air Dampers and Barometric Relief Dampers for 072/090 models include a filler panel for proper cabinet fit.

Options/Accessories

Factory Installed

Corrosion Protection

A completely flexible immersed coating with an electrodeposited dry film process. (AST ElectroFin E-Coat) Meets Mil Spec MIL-P-53084, ASTM B117 Standard Method Salt Spray Testing.

Indoor Corrosion Protection:-
Coated coil

- Painted blower housing
- Painted base

Outdoor Corrosion Protection:

- Coated coil
- Painted base

9 Hinged Access Panels

Large access panels are hinged and have quarter-turn latches for quick and easy access to maintenance areas (economizer / filter, compressor / controls, heating / blower).

Field Installed

Coil Guards

Painted, galvanized steel wire guards to protect outdoor coil. Not used with Hail Guards.

Hail Guards

Constructed of heavy gauge steel, painted to match cabinet, helps protect outdoor coils from hail damage. Not used with Coil Guards.

FEATURES AND BENEFITS

CONTROLS

Unit Control

All control voltage is provided via a 24V (secondary) transformer with built-in circuit breaker protection.

Heat/Cool Staging - Capable of up to 2 heat / 2 cool staging with a third party DDC control system or thermostat.

Low Voltage Terminal Block - Provides screw terminal connections for thermostat or controller wiring.

Night Setback Mode - Saves energy by closing outdoor air dampers and operating supply fan on thermostat demand only.

Options/Accessories

Field Installed

Commercial Control Systems

L Connection® Network

Complete building automation control system for single or multi-zone applications. Options include local interface, software for local or remote communication, and hardware for networking other control functions. See L Connection Network Product Specifications Bulletin for details.

Smoke Detector

Photoelectric type, installed in supply air section, return air section or both sections. Available with power board and single sensor (supply or return) or power board and two sensors (supply and return). Power board located in unit control compartment.

Thermostats

Control system and thermostat options, see page 37.

Aftermarket unit controller options, see Options/Accessories table.

10 BLOWER

A wide selection of supply air blower options are available to meet a variety of air flow requirements.

Motor

Overload protected, equipped with ball bearings (belt drive) or sleeve bearings (direct drive).

Direct drive motors are offered on 024, 030, 036, 048 and 060 models.

Belt drive motors are offered on 036, 048, 060, 072 and 090 models and are available in several different sizes to maximize air performance.

Supply Air Blower

Forward curved blades, blower wheel is statically and dynamically balanced.

All belt drive motors have adjustable pulley for speed change.

Ordering Information

Specify direct drive or belt drive motor

For belt drive, specify motor horsepower and drive kit number when base unit is ordered.

Required Selections

Supply Air Blower

Order one, belt drive or direct drive (See Blower Data Table for specifications).

Order one drive kit, belt drive only, see Drive Kit Specifications Table.

INDOOR AIR QUALITY

Air Filters

Disposable 2 inch filters furnished as standard.

Options/Accessories

Field Installed

Healthy Climate® High Efficiency Air Filters

Disposable MERV 8 or MERV 13 (Minimum Efficiency Reporting Value based on ASHRAE 52.2) efficiency 2 inch pleated filters.

Healthy Climate® UVC Germicidal Lamps

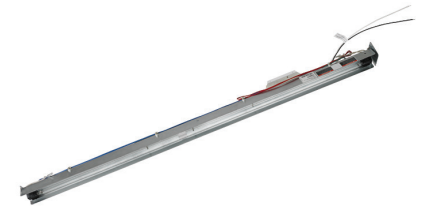

Helps eliminate mold and bacterial growth on the evaporator and drain pans. Improves indoor air quality and maintains efficiency of system by reducing fouling of evaporator coil.

Indoor Air Quality (CO₂) Sensor

Monitors CO₂ levels adjusts economizer dampers as needed for Demand Control Ventilation

FEATURES AND BENEFITS

ELECTRICAL

Marked & Color-Coded Wiring

All electrical wiring is color-coded and marked to identify which components it is connecting.

Electrical Plugs

Positive connection electrical plugs are used to connect common accessories or maintenance parts for easy removal or installation.

Required Selections

Voltage Choice

Specify when ordering base unit.

Options/Accessories

Factory or Field Installed

Disconnect Switch up to 150 Amp

Accessible from outside of unit, spring loaded weatherproof cover furnished. Main power to the unit is field connected to the disconnect which allows all power to be shut off for service. See Electrical/ Electric Heat tables for ordering information, page 30.

GFI Service Outlets (2)

115V ground fault circuit interrupter (GFCI) type, non-powered, field-wired.

Field Installed

① Electric Heat

Helix wound nichrome elements, individual element limit controls, wiring harness. Unit fuse block is furnished as standard. See Options / Accessories tables for ordering information.

GFI Weatherproof Cover

Single-gang cover.

Heavy-duty UV-resistant polycarbonate case construction.

Hinged base cover with gasket.

ECONOMIZER OPTIONS

Factory or Field Installed

12 Economizer (Standard and High Performance Common Features)

Outdoor Air Hood is furnished.

Factory installed Economizer can be ordered with two exhaust options:

- Barometric Relief Dampers and Exhaust Hood.
- No Exhaust.

Field installed Economizer includes Barometric Relief Dampers with Exhaust Hood.

Barometric Relief Dampers allow relief of excess air, aluminum blade dampers prevent blow back and outdoor air infiltration during off cycle, bird screen furnished.

Occupied/Unoccupied mode with field furnished setback thermostat.

Demand Control Ventilation (DCV) ready using optional CO₂ sensors.

Mixed Air Sensor is furnished for field installation in the rooftop unit. Sensor is factory installed when Economizers are factory installed.

Single sensible sensor is furnished with Economizer and enables economizer operation if the outdoor temperature is less than the setpoint of the control.

Horizontal Economizer Conversion kit is available for field installation.

Standard Economizer Features (Not for Title 24)

Gear-driven action, return air and outdoor air dampers, plug-in connections to unit, neoprene seals, 24-volt, fully-modulating spring return motor.

Standard Economizer Control Module

The Standard Economizer Control Module can be adjusted to operate based on outdoor air temperatures.



Economizer Controls:

- Damper Minimum Position - Can be set lower than traditional minimum air requirements resulting in cost savings.
- IAQ Sensor - Signals dampers to modulate and maintain 55°F when CO₂ is higher than the CO₂ setpoint.
- Demand Control Ventilation (DCV) LED - A steady green Demand Control Ventilation LED indicates the IAQ reading is higher than setpoint and requires more fresh air.
- Free Cool LED - A steady green LED indicates outdoor air is suitable for free cooling.

Free Cooling runs when outdoor air temperature is lower than the set temperature on the economizer control.

NOTE: The Free Cooling default setting for outdoor air temperature sensor is 55°F.

High Performance Economizer Features

Approved for California Title 24 building standards.

ASHRAE 90.1-2010 compliant.

Gear-driven action, high torque 24-volt fully-modulating spring return damper motor, return air and outdoor air dampers, plug-in connections to unit, nylon bearings, enhanced neoprene blade edge seals and flexible stainless steel jamb seals to minimize air leakage.

NOTE - High Performance Economizers are not approved for use with enthalpy controls in Title 24 applications.

High Performance Economizer Control Module

Module provides inputs and outputs to control economizer based on parameter settings.



Module automatically detects sensors by polling to determine which sensors are installed in system.

Module displays any alarm messages (fault detection and diagnostics) as an aid in troubleshooting.

Non-volatile memory retains parameter settings in case of power failure.

Keypad with four navigation buttons and LCD screen is furnished for setting economizer parameters.

- Menu Up/Exit (↑) button returns to the main menu.
- Arrow Up (▲) button moves to the previous or next parameter within the selected menu.
- Arrow Down (▼) button moves to the next parameter within the selected menu.
- Select (enter) (↵) button confirms parameter selection.

Main Menu Structure:

- STATUS (economizer and system operation status)
- SETPOINTS (settings for various setpoint parameters)
- SYSTEM SETUP (settings/information about the system)
- ADVANCED SETUP (freeze protection, CO₂ settings, stage 3 delay and additional calibration settings)
- CHECKOUT (damper positions)
- ALARMS (output signal that can be configured for remote alarm monitoring)

NOTE - The Free Cooling setpoint for Title 24 applications must be set based on the Climate Zone where the system is installed. See Section 140.4 "Prescriptive Requirements for Space Conditioning Systems" of the California Energy Commission's 2013 Building Energy Efficiency Standards.

Refer to Installation Instructions for complete setup information and menu parameters available.

OPTIONS / ACCESSORIES

ECONOMIZER OPTIONS (continued)

Factory or Field Installed

Single Enthalpy Temperature Control (Not for Title 24)

Outdoor air enthalpy sensor enables Economizer if the outdoor enthalpy is less than the setpoint of the control.

Field Installed

Differential Enthalpy Control (Not for Title 24)

Order two Single Enthalpy Controls. One is field installed in the return air section, the other in the outdoor air section. Allows the economizer control board to select between outdoor air or return air, whichever has lower enthalpy.

Horizontal Economizer Conversion Kit

Insulated panel covers the bottom return air opening on the unit base to convert downflow Economizer to horizontal airflow.

EXHAUST OPTIONS

Field Installed

13 Power Exhaust Fan

Installs internal to unit for downflow applications only with Economizer option. Provides exhaust air pressure relief. Interlocked to run when supply air blower is operating, fan runs when outdoor air dampers are 50% open (adjustable), motor is overload protected.

Fan is 16 in. diameter with 4 fan blades and a 1/3 hp motor.

NOTE - Not available for 024 and 030 models.

NOTE - If Power Exhaust is field installed with a factory installed Economizer, the Economizer must be ordered with the "No Exhaust" option and the Barometric Relief Dampers with Exhaust Hood must also be ordered separately for field installation.

OUTDOOR AIR OPTIONS

Factory or Field Installed

Outdoor Air Dampers - Downflow or Horizontal

Linked mechanical dampers, 0 to 35% (fixed) outdoor air adjustable, installs in unit.

Automatic model features fully modulating spring return damper motor with plug-in connection.

Manual model features a slide damper. Maximum mixed air temperature in cooling mode: 100°F.

Outdoor Air Hood is furnished.

ROOF CURBS

Hybrid Roof Curbs, Downflow

Nailer strip furnished, mates to unit, US National Roofing Contractors Approved, shipped knocked down.

Roof curb can be assembled using interlocking tabs to fasten corners together. No tools required.

Curb can also be fastened together with furnished hardware.

Available in 8, 14, 18, and 24 inch heights.

Full Perimeter Curbs, Downflow (090 Models Only)

Clip Curbs use interlocking tabs to fasten together. No tools required.

Hinged curb corners fasten together with furnished hinge pins.

Standard roof curb corners fasten together with furnished hardware.

NOTE - 090 models can be used on smaller 79-3/4 in. Hybrid Roof Curbs (not full perimeter) with 15-3/4 in. overhang at condenser end of unit. See dimension drawing on page 46.

Adaptor Curbs (not shown)

Curbs are regionally sourced. Dimensions will vary based upon the source. Contact your local sales representative for a detailed cut sheet with applicable dimensions.

CEILING DIFFUSERS

Ceiling Diffusers (Flush and Step-Down)

Aluminum grilles, large center grille, insulated diffuser box with flanges, hanging rings furnished, interior transition (even air flow), internally sealed (prevents recirculation), adapts to T-bar ceiling grids or plaster ceilings.

Transitions (Supply and Return)

Used with diffusers, installs in roof curb, galvanized steel construction, flanges furnished for duct connection to diffusers, fully insulated.

OPTIONS / ACCESSORIES

Item	Model No.	Catalog No.	Unit Model No.						
			024	030	036	048	060	072	090
COOLING SYSTEM									
Condensate Drain Trap	PVC - C1TRAP20AD2	76W26	X	X	X	X	X	X	X
	Copper - C1TRAP10AD2	76W27	X	X	X	X	X	X	X
Corrosion Protection			O	O	O	O	O	O	O
Compressor Crankcase Heater	208/230V-1 or 3 ph - K1CCHT02A-1P	39W04	X	X	X				
	208/230V-1 or 3 ph - T1CCHT01AN1P	95M07				X	X		X
	460V-3ph - K1CCHT012A-1G	39W05			X				
	460V-3ph - T1CCHT01AN1G	95M08				X	X		X
	575V-3ph - K1CCHT02A-1J	39W06			X				
	575V-3ph - T1CCHT01AN1J	95M09				X	X		X
Drain Pan Overflow Switch	K1SNSR71AB1-	74W42	X	X	X	X	X	X	X
Low Ambient Kit	K1SNSR33AN1	41W33	X	X	X	X	X	X	X
Efficiency		Standard	O	O	O	O	O	O	O
Refrigerant Type		R-410A	O	O	O	O	O	O	O
BLOWER - SUPPLY AIR									
Motors	Direct Drive - 0.25 hp		O	O					
	Direct Drive - 0.5 hp				O	O			
	Direct Drive - 0.75 hp						O		
	¹ Belt Drive - 1 hp Standard Efficiency				O	O	O	O	O
	² Belt Drive - 1.5 hp Standard Efficiency				O	O	O		
	¹ Belt Drive - 2 hp Standard Efficiency				O	O	O	O	O
	Belt Drive - 3 hp Standard Efficiency								O
Drive Kits See Blower Data Tables for selection	Kit A01 - T1DRKT001-1 - 673-1010 rpm	Factory			O				
	Kit A02 - T1DRKT002-1 - 745-1117 rpm	Factory				O			
	Kit A03 - T1DRKT003-1 - 833-1250 rpm	Factory					O		
	Kit A04 - T1DRKT004-1 - 968-1340 rpm	Factory						O	
	Kit A05 - T1DRKT005-1 - 897-1346 rpm	Factory			O				
	Kit A06 - T1DRKT006-1 - 1071-1429 rpm	Factory				O			
	Kit A07 - T1DRKT007-1 - 1212-1548 rpm	Factory					O		
	Kit A08 - T1DRKT008-1 - 1193-1591 rpm	Factory						O	
	Kit AA01 - T1DRKT001AP1 - 522-784 rpm	Factory							O
	Kit AA02 - T1DRKT002AP1 - 632-875 rpm	Factory							O
Kit AA03 - T1DRKT003AP1 - 798-1105 rpm	Factory							O	
Kit AA04 - T1DRKT004AP1 - 921-1228 rpm	Factory							O	
CABINET									
Coil Guards	T1GARD20A-1	17W87	X	X	X	X	X		
	T1GARD20N-1	17W88						X	
	K1GARD20AP1	53W21							X
Hail Guards	T1GARD10A-1	17W89	X	X	X	X	X		
	T1GARD10N-1	17W90						X	
	K1GARD10AP1	53W22							X
Hinged Access Panels			O	O	O	O	O	O	O
CONTROLS									
Commercial Controls	L Connection® Building Automation System	- - -	X	X	X	X	X	X	X
BACnet®	K0CTRL31A-1	96W14	OX	OX	OX	OX	OX		
	K0CTRL31AP1	12B99						OX	OX
BACnet® Thermostat with Display	K0SNSR01FF1	97W23	X	X	X	X	X	X	X
BACnet® Thermostat without Display	K0SNSR00FF1	97W24	X	X	X	X	X	X	X
Novar® 2051	K0CTRL30A-1	96W11	OX	OX	OX	OX	OX		
	K0CTRL30AP1	12B98						OX	OX
Plenum Cable (75 ft.)	K0MISC00FF1	97W25	X	X	X	X	X	X	X
Smoke Detector - Supply or Return (Power board and one sensor)	C1SNSR44AP1	53W78	X	X	X	X	X	X	X
Smoke Detector - Supply and Return (Power board and two sensors)	C1SNSR43AP1	53W79	X	X	X	X	X	X	X

¹ 1 hp and 2 hp blower motors are not available for 208/230V-1ph applications.

² 1.5 hp blower motor is only available for 208/230V-1ph applications.

NOTE - The catalog and model numbers that appear here are for ordering field installed accessories only.

OX - Field Installed or Configure to Order (factory installed)

O - Configure to Order (Factory Installed)

X - Field Installed.

OPTIONS / ACCESSORIES

Item	Model No.	Catalog No.	Unit Model No.						
			024	030	036	048	060	072	090
ECONOMIZER									
Standard Economizer With Outdoor Air Hood (Sensible Control) (Not for Title 24)									
Standard Economizer - Includes Barometric Relief Dampers and Exhaust Hood	K1ECON30A-2-	90W61	OX	OX	OX	OX	OX	OX	OX
Standard Economizer - No Exhaust	Factory		O	O	O	O	O	O	O
Standard Economizer Controls (Not for Title 24)									
Single Enthalpy Control	C1SNSR64FF1	53W64	OX	OX	OX	OX	OX	OX	OX
Differential Enthalpy Control (order 2)	C1SNSR64FF1	53W64	X	X	X	X	X	X	X
High Performance Economizer With Outdoor Air Hood (Sensible Control) (Approved for California Title 24 Building Standards)									
High Performance Economizer - Includes Barometric Relief Dampers and Exhaust Hood	K1ECON32A-1	10U56	OX	OX	OX	OX	OX	OX	OX
High Performance Economizer Controls (Not for Title 24)									
Single Enthalpy Control	C1SNSR60FF1	10Z75	OX	OX	OX	OX	OX	OX	OX
Differential Enthalpy Control (order 2)	C1SNSR60FF1	10Z75	X	X	X	X	X	X	X
Economizer Accessories									
Horizontal Economizer Conversion Kit	T1HECK00AN1	17W45	X	X	X	X	X	X	X
OUTDOOR AIR									
Outdoor Air Dampers With Outdoor Air Hood									
Motorized	K1DAMP21A-1	79W95	OX	OX	OX	OX	OX	OX	OX
Manual	C1DAMP11A-1	53W34	OX	OX	OX	OX	OX	OX	OX
POWER EXHAUST FAN									
Standard Static	208/230V-1 or 3ph - C1PWRE10A-1P	79W87			X	X	X	X	X
<i>NOTE - Order Barometric Relief Dampers with Exhaust Hood below if unit is ordered with factory installed Standard Economizer with "No Exhaust" option</i>	460V-3ph - C1PWRE10A-1G	79W88			X	X	X	X	X
	575V-3ph - C1PWRE10A-1J	79W89			X	X	X	X	X
' BAROMETRIC RELIEF									
Barometric Relief Dampers with Exhaust Hood	C1DAMP50A-1-	74W38	X	X	X	X	X	X	X
ELECTRICAL									
Voltage	208/230V - 1 phase		O	O	O	O	O		
60 hz	208/230V - 3 phase				O	O	O	O	O
	460V - 3 phase				O	O	O	O	O
	575V - 3 phase				O	O	O	O	O
Disconnect	See Electrical/Electric Heat Tables for selection		OX	OX	OX	OX	OX	OX	OX
GFI Service	15 amp non-powered, field-wired (208/230V, 460V only)	LTAGFIK10/15	74M70	OX	OX	OX	OX	OX	OX
Outlets	20 amp non-powered, field-wired (575V only)	C1GFCI20FF1	67E01	X	X	X	X	X	X
Weatherproof Cover for GFI	C1GFCI99FF1	10C89	X	X	X	X	X	X	X

¹ Required when Economizer is factory installed (no exhaust option) with field installed Power Exhaust Fan option.

NOTE - The catalog and model numbers that appear here are for ordering field installed accessories only.

OX - Field Installed or Configure to Order (factory installed)

O - Configure to Order (Factory Installed)

X - Field Installed.

OPTIONS / ACCESSORIES

Item	Model No.	Catalog No.	Unit Model No.						
			024	030	036	048	060	072	090
ELECTRIC HEAT									
7.5 kW	208/230V-1ph - T1EH0075AN1P	14W32	X	X	X	X	X		
	208/230V-3ph - T1EH0075AN1Y	14W35			X	X	X	X	X
	460V-3ph - T1EH0075AN1G	14W39			X	X	X	X	X
	575V-3ph - T1EH0075AN1J	14W43			X	X	X	X	X
10 kW	208/230V-1ph - T1EH0100A1P	30W26	X	X					
15 kW	208/230V-1ph - T1EH0150AN1P	14W33			X	X	X		
	208/230V-3ph - T1EH0150AN1Y	14W36			X	X	X	X	X
	460V-3ph - T1EH0150AN1G	14W40			X	X	X	X	X
	575V-3ph - T1EH0150AN1J	14W44			X	X	X	X	X
22.5 kW	208/230V-1ph - T1EH0225AN1P	14W34					X		
	208/230V-3ph - T1EH0225AN1Y	14W37					X	X	X
	460V-3ph - T1EH0225AN1G	14W41					X	X	X
	575V-3ph - T1EH0225AN1J	14W45					X	X	X
30 kW	208/230V-3ph - T1EH0300N-1Y	14W38						X	X
	460V-3ph - T1EH0300N-1G	14W42						X	X
	575V-3ph - T1EH0300N-1J	14W46						X	X

INDOOR AIR QUALITY

Air Filters

Healthy Climate® High Efficiency Air Filters Order 4 per unit	MERV 8 (16 x 20 x 2) - C1FLTR15A-1-	54W20	X	X	X	X	X		
	MERV 13 (16 x 20 x 2) - T1FLTR40A-1-	52W37	X	X	X	X	X		
	MERV 8 (20 x 20 x 2) - C1FLTR15D-1-	54W21						X	X
	MERV 13 (20 x 20 x 2) - C1FLTR40D-1-	52W39						X	X

Indoor Air Quality (CO₂) Sensors

Sensor - Wall-mount, off-white plastic cover with LCD display	C0SNSR50AE1L	77N39	X	X	X	X	X	X	X
Sensor - Wall-mount, black plastic case, no display, rated for plenum mounting	C0SNSR53AE1L	87N54	X	X	X	X	X	X	X
CO ₂ Sensor Duct Mounting Kit - for downflow applications	C0MISC19AE1-	85L43	X	X	X	X	X	X	X
Aspiration Box - for duct mounting non-plenum rated CO ₂ sensor (77N39)	C0MISC16AE1-	90N43	X	X	X	X	X	X	X

UVC Germicidal Lamps

¹ Healthy Climate® UVC Light Kit (208/230v-1ph)	E1UVCL10AN1-	50W90	X	X	X	X	X	X	X
--	--------------	--------------	---	---	---	---	---	---	---

¹ Lamps operate on 110-230V single-phase power supply. Step-down transformer may be ordered separately for 460V and 575V units. Alternately, 110V power supply may be used to directly power the UVC ballast(s).

NOTE - The catalog and model numbers that appear here are for ordering field installed accessories only.

OX - Field Installed or Configure to Order (factory installed)

O - Configure to Order (Factory Installed)

X - Field Installed.

OPTIONS / ACCESSORIES

Item	Model No.	Catalog No.	Unit Model No.						
			024	030	036	048	060	072	090
CEILING DIFFUSERS									
Step-Down - Order one	RTD9-65-R	27G87	X	X	X	X	X		
	RTD11-95	29G04						X	X
Flush - Order one	FD9-65-R	27G86	X	X	X	X	X		
	FD11-95	29G08						X	X
Transitions (Supply and Return) - Order one	T1TRAN10AN1	17W53	X	X	X	X	X		
	T1TRAN20N-1	17W54						X	X

ROOF CURBS

Hybrid Roof Curbs, Downflow

8 in. height	C1CURB70A-1	11F50	X	X	X	X	X	X	1 X
14 in. height	C1CURB71A-1	11F51	X	X	X	X	X	X	1 X
18 in. height	C1CURB72A-1	11F52	X	X	X	X	X	X	1 X
24 in. height	C1CURB73A-1	11F53	X	X	X	X	X	X	1 X

Clip Curbs, Full Perimeter, Downflow

8 in. height	K1CURB23AP1	52W20							X
14 in. height	K1CURB20AP1	52W21							X
18 in. height	K1CURB21AP1	52W22							X
24 in. height	K1CURB22AP1	52W23							X

Hinged, Full Perimeter, Downflow

8 in. height	K1CURB30AP1	52W17							X
18 in. height	K1CURB32AP1	52W18							X
24 in. height	K1CURB33AP1	52W19							X

Standard, Full Perimeter, Downflow

14 in. height	K1CURB10AP1	52W24							X
---------------	-------------	--------------	--	--	--	--	--	--	---

Adjustable Pitched Curb

14 in. height	C1CURB55AT1	43W27	X	X	X	X	X	X	1 X
---------------	-------------	--------------	---	---	---	---	---	---	-----

¹ 090 models will fit smaller roof curbs with overhang. See dimension drawing.

NOTE - The catalog and model numbers that appear here are for ordering field installed accessories only.

OX - Field Installed or Configure to Order (factory installed)

O - Configure to Order (Factory Installed)

X - Field Installed.

SPECIFICATIONS - DIRECT DRIVE BLOWER
2 - 2.5 TON

General Data		Nominal Tonnage	2 Ton	2.5 Ton
		Model No.	KCA024S4D	KCA030S4D
		Efficiency Type	Standard	Standard
Cooling Performance	Gross Cooling Capacity - Btuh		24,400	29,800
	¹ Net Cooling Capacity - Btuh		23,600	28,800
	AHRI Rated Air Flow - cfm		840	1000
	² Sound Rating Number (SRN) ((dBA)		75	75
	Total Unit Power - kW		2.1	2.6
	¹ SEER (Btuh/Watt)		13	13
	¹ EER (Btuh/Watt)		11.4	11.2
Refrigerant	Type		R-410A	R-410A
	Charge Furnished		7 lbs. 0 oz.	7 lbs. 12 oz.
Electric Heat Available - See page 11			7.5, 10 kW	7.5, 10 kW
Compressor Type (one per unit)			Scroll	Scroll
Outdoor Coil	Net face area - sq. ft.		15.6	15.6
	Tube diameter - in.		3/8	3/8
	Number of rows		1	1
	Fins per inch		20	20
Outdoor Coil Fan	Motor HP		1/4	1/4
	Motor rpm		825	825
	Total motor watts		250	250
	Diameter - in. / No. of blades		24 - 3	24 - 3
	Total air volume - cfm		3700	3700
Indoor Coil	Net face area - sq. ft.		7.8	7.8
	Tube diameter - in.		3/8	3/8
	Number of rows		3	3
	Fins per inch		14	14
	Drain Connection (no. and size) - in.		(1) 1 NPT	(1) 1 NPT
	Expansion device type		Balanced Port Thermostatic Expansion Valve, removeable power head	
Indoor Blower	Nominal Motor HP		.25	.25
	Wheel nominal diameter x width - in.		10 x 10	10 x 10
Filters	Type		Disposable	
	Number and size - in.		(4) 16 x 20 x 2	
Electrical Characteristics - 60 Hz			208/230V 1 phase	208/230V 1 phase

NOTE - Net capacity includes evaporator blower motor heat deduction. Gross capacity does not include evaporator blower motor heat deduction.

¹ AHRI Certified to AHRI Standard 210/240: 95°F outdoor air temperature and 80°F db/67°F wb entering evaporator air; minimum external duct static pressure.

² Sound Rating Number (SRN) rated in accordance with test conditions included in ARI Standard 270-95.

SPECIFICATIONS - DIRECT DRIVE BLOWER
3 - 5 TON

General Data		Nominal Tonnage	3 Ton	4 Ton	5 Ton
		Model No.	KCA036S4D	KCA048S4D	KCA060S4D
		Efficiency Type	Standard	Standard	Standard
Cooling Performance	Gross Cooling Capacity - Btuh		37,500	50,000	61,800
	¹ Net Cooling Capacity - Btuh		36,000	48,000	59,000
	AHRI Rated Air Flow - cfm		1200	1600	1800
	² Sound Rating Number (SRN)((dBA)		75	75	82
	Total Unit Power - kW		3.4	4.4	5.3
	¹ SEER (Btuh/Watt)		13	13	13
	¹ EER (Btuh/Watt)		10.7	11	11.2
Refrigerant	Type		R-410A	R-410A	R-410A
	Charge Furnished		8 lbs. 5 oz.	8 lbs. 10 oz.	11 lbs. 0 oz.
Electric Heat Available - See page 11			7.5, 15 kW	7.5, 15 kW	7.5, 15, 22.5 kW
Compressor Type (one per unit)			Scroll	Scroll	Scroll
Outdoor Coil	Net face area - sq. ft.		15.6	15.6	15.6
	Tube diameter - in.		3/8	3/8	3/8
	Number of rows		1	1.5	2
	Fins per inch		20	20	20
Outdoor Coil Fan	Motor HP		1/4	1/4	1/3
	Motor rpm		825	825	1075
	Total motor watts		250	250	370
	Diameter - in. / No. of blades		24 - 3	24 - 3	24 - 3
	Total air volume - cfm		3700	3500	4300
Indoor Coil	Net face area - sq. ft.		7.8	7.8	7.8
	Tube diameter - in.		3/8	3/8	3/8
	Number of rows		3	3	4
	Fins per inch		14	14	14
	Drain Connection (no. and size) - in.		(1) 1 NPT	(1) 1 NPT	(1) 1 NPT
	Expansion device type		Balanced Port Thermostatic Expansion Valve, removeable power head		
Indoor Blower	Nominal Motor HP		.5	.5	.75
	Wheel nominal diameter x width - in.		10 x 10	10 x 10	11 x 10
Filters	Type		Disposable		
	Number and size - in.		(4) 16 x 20 x 2		
Electrical Characteristics - 60 Hz			208/230V 1 phase	208/230V 1 phase	208/230V 1 phase
			208/230V, 460V & 575V 3 phase	208/230V, 460V & 575V 3 phase	208/230V, 460V & 575V 3 phase

NOTE - Net capacity includes evaporator blower motor heat deduction. Gross capacity does not include evaporator blower motor heat deduction.

¹ AHRI Certified to AHRI Standard 210/240: 95°F outdoor air temperature and 80°F db/67°F wb entering evaporator air; minimum external duct static pressure.

² Sound Rating Number (SRN) rated in accordance with test conditions included in ARI Standard 270-95.

SPECIFICATIONS - BELT DRIVE BLOWER

3 - 7.5 TON

General Data		Nominal Tonnage	3 Ton	4 Ton	5 Ton	6 Ton	7.5 Ton
		Model No.	KCA036S4B	KCA048S4B	KCA060S4B	KCA072S4B	KCA090S4B
		Efficiency Type	Standard	Standard	Standard	Standard	Standard
Cooling Performance	Gross Cooling Capacity - Btuh		37,500	50,000	61,800	72,800	92,000
	Net Cooling Capacity - Btuh		¹ 36,000	¹ 48,000	¹ 59,000	² 70,000	² 90,000
	AHRI Rated Air Flow - cfm		1200	1600	1800	2100	2430
	³ Sound Rating Number (SRN) (dBA)		75	75	82	82	79
	Total Unit Power - kW		3.4	4.4	5.3	6.3	8.2
	SEER (Btuh/Watt)		¹ 13.0	¹ 13.0	¹ 13.0	---	---
	IEER (Btuh/Watt)		---	---	---	² 11.4	² 11.4
	EER (Btuh/Watt)		¹ 10.7	¹ 11	¹ 11.2	² 11.2	² 11.2
Refrigerant		Type	R-410A	R-410A	R-410A	R-410A	R-410A
		Charge Furnished	8 lbs. 5 oz.	8 lbs. 10 oz.	11 lbs. 0 oz.	14 lbs. 12 oz.	8 lbs. 10 oz.
Electric Heat Available - See page 11			7.5, 15 kW	7.5, 15 kW	7.5, 15, 22.5 kW	7.5, 15, 22.5, 30 kW	
Compressor Type (one per unit)			Scroll	Scroll	Scroll	Scroll	Scroll
Outdoor Coil	Net face area - sq. ft.		15.6	15.6	15.6	19.3	24.2
	Tube diameter - in.		3/8	3/8	3/8	3/8	---
	Number of rows		1	1.5	2	2	1
	Fins / inch		20	20	20	20	23
Outdoor Coil Fan	Motor HP		1/4	1/4	1/3	1/3	1/2
	Motor rpm		825	825	1075	1075	1075
	Total motor watts		250	250	370	405	520
	Diameter - in. / No. of blades		24 - 3	24 - 3	24 - 3	24 - 3	24 - 4
	Total air volume - cfm		3700	3500	4300	4800	5300
Indoor Coil	Net face area - sq. ft.		7.8	7.8	7.8	9.7	9.7
	Tube diameter - in.		3/8	3/8	3/8	3/8	3/8
	Number of rows		3	3	4	4	4
	Fins per inch		14	14	14	14	14
	Drain Connection (no. and size) - in.		(1) 1 NPT	(1) 1 NPT	(1) 1 NPT	(1) 1 NPT	(1) 1 NPT
	Expansion device type		Balanced Port Thermostatic Expansion Valve, removeable power head				
⁴ Indoor Blower & Drive Selection	Nominal Motor HP		⁵ 1 hp, ⁶ 1.5 hp, ⁵ 2 hp	⁵ 1 hp, ⁶ 1.5 hp, ⁵ 2 hp	⁵ 1 hp, ⁶ 1.5 hp, ⁵ 2 hp	1 hp, 2 hp	1 hp
	Maximum Usable Motor HP		1.15 hp, 1.7 hp, 2.3 hp	1.15 hp, 1.7 hp, 2.3 hp	1.15 hp, 1.7 hp, 2.3 hp	1.15 hp, 2.3 hp	1.15 hp
	Available Drive Kits		A01	A02	A03	A04	AA01
			673 - 1010 rpm	745 - 1117 rpm	833 - 1250 rpm	968 - 1340 rpm	522 - 784 rpm
			A05 897 - 1346 rpm	A06 1071 - 1429 rpm	A07 1212 - 1548 rpm	A08 1193 - 1591 rpm	
	Nominal Motor HP		---	---	---	---	2 hp
	Maximum Usable Motor HP		---	---	---	---	2.3 hp
	Available Drive Kits		---	---	---	---	AA02
			---	---	---	---	632 - 875 rpm
			---	---	---	---	AA03
		---	---	---	---	798 - 1105 rpm	
		---	---	---	---	3 hp	
		---	---	---	---	3.45 hp	
		---	---	---	---	AA04	
		---	---	---	---	921 - 1228 rpm	
Wheel nominal diameter x width - in.			10 x 10	10 x 10	10 x 10	10 x 10	15 x 9
Filters	Type		Disposable			Disposable	
	Number and size - in.		(4) 16 x 20 x 2			(4) 20 x 20 x 2	
Electrical Characteristics - 60 Hz			208/230V 1 phase	208/230V, 1 phase	208/230V 1 phase	208/230V, 460V & 575V 3 phase	208/230V, 460V & 575V 3 phase
			208/230V, 460V & 575V 3 phase	208/230V 460V & 575V 3 phase	208/230V, 460V & 575V 3 phase		

NOTE - Net capacity includes evaporator blower motor heat deduction. Gross capacity does not include evaporator blower motor heat deduction.

^{1,2} AHRI Certified to AHRI Standard ¹ 210/240 or ² 340/360: 95°F outdoor air temperature and 80°F db/67°F wb entering evaporator air; minimum external duct static pressure.

³ Sound Rating Number (SRN) rated in accordance with test conditions included in ARI Standard 270-95.

⁴ Using total air volume and system static pressure requirements determine from blower performance tables rpm and motor hp required. Maximum usable hp of motors furnished are shown. In Canada, nominal motor hp is also maximum usable motor hp output. If motors of comparable hp are used, be sure to keep within the service factor limitations outlined on the motor nameplate.

⁵ 1 hp and 2 hp blower motors are not available for 208/230V-1ph applications.

⁶ 1.5 hp blower motor only available for 208/230V-1ph applications.

RATINGS

NOTE – For Temperatures and Capacities not shown in tables, see bulletin – Cooling Unit Rating Table Correction Factor Data in Miscellaneous Engineering Data section.

2 TON - KCA024S4

Entering Wet Bulb Temperature	Total Air Volume	Outdoor Air Temperature Entering Outdoor Coil																			
		85°F					95°F					105°F					115°F				
		Total Cool Cap.	Comp. Motor Input	Sensible To Total Ratio (S/T)			Total Cool Cap.	Comp. Motor Input	Sensible To Total Ratio (S/T)			Total Cool Cap.	Comp. Motor Input	Sensible To Total Ratio (S/T)			Total Cool Cap.	Comp. Motor Input	Sensible To Total Ratio (S/T)		
				Dry Bulb					Dry Bulb					Dry Bulb					Dry Bulb		
cfm	kBtuh	kW	75°F	80°F	85°F	kBtuh	kW	75°F	80°F	85°F	kBtuh	kW	75°F	80°F	85°F	kBtuh	kW	75°F	80°F	85°F	
63°F	640	23.1	1.37	0.71	0.86	0.99	21.4	1.57	0.72	0.88	1	19.6	1.79	0.73	0.9	1	17.7	2.05	0.75	0.93	1
	800	24.6	1.37	0.77	0.94	1	22.8	1.57	0.79	0.96	1	20.9	1.8	0.8	0.99	1	19	2.05	0.83	1	1
	960	25.8	1.38	0.83	1	1	24.1	1.58	0.85	1	1	22.3	1.8	0.88	1	1	20.3	2.06	0.91	1	1
67°F	640	24.8	1.37	0.56	0.69	0.82	23	1.58	0.55	0.7	0.84	21.1	1.8	0.55	0.71	0.87	19.1	2.05	0.55	0.72	0.89
	800	26.3	1.38	0.59	0.75	0.91	24.3	1.58	0.59	0.77	0.93	22.4	1.8	0.6	0.78	0.96	20.2	2.06	0.6	0.81	0.99
	960	27.4	1.38	0.63	0.81	0.98	25.4	1.58	0.63	0.83	1	23.3	1.81	0.65	0.86	1	21.1	2.06	0.66	0.89	1
71°F	640	26.4	1.38	0.41	0.54	0.67	24.5	1.58	0.4	0.55	0.68	22.6	1.81	0.39	0.54	0.69	20.6	2.06	0.37	0.54	0.7
	800	28	1.38	0.44	0.59	0.73	25.9	1.59	0.42	0.59	0.75	23.9	1.81	0.41	0.59	0.76	21.7	2.06	0.39	0.6	0.78
	960	29.1	1.38	0.44	0.62	0.79	27	1.59	0.43	0.63	0.81	24.8	1.82	0.45	0.63	0.83	22.5	2.07	0.43	0.65	0.87

2.5 TON - KCA030S4

Entering Wet Bulb Temperature	Total Air Volume	Outdoor Air Temperature Entering Outdoor Coil																			
		85°F					95°F					105°F					115°F				
		Total Cool Cap.	Comp. Motor Input	Sensible To Total Ratio (S/T)			Total Cool Cap.	Comp. Motor Input	Sensible To Total Ratio (S/T)			Total Cool Cap.	Comp. Motor Input	Sensible To Total Ratio (S/T)			Total Cool Cap.	Comp. Motor Input	Sensible To Total Ratio (S/T)		
				Dry Bulb					Dry Bulb					Dry Bulb					Dry Bulb		
cfm	kBtuh	kW	75°F	80°F	85°F	kBtuh	kW	75°F	80°F	85°F	kBtuh	kW	75°F	80°F	85°F	kBtuh	kW	75°F	80°F	85°F	
63°F	800	28.3	1.75	0.7	0.86	0.99	25.8	1.99	0.71	0.87	1	23.3	2.26	0.71	0.9	1	20.7	2.58	0.72	0.93	1
	1000	30.2	1.76	0.77	0.94	1	27.7	2	0.78	0.96	1	25.1	2.27	0.79	0.99	1	22.5	2.58	0.81	1	1
	1200	31.8	1.77	0.83	1	1	29.4	2.01	0.85	1	1	27	2.28	0.87	1	1	24.2	2.58	0.9	1	1
67°F	800	30.6	1.76	0.54	0.69	0.82	28.1	2	0.53	0.69	0.84	25.4	2.27	0.52	0.7	0.86	22.6	2.58	0.51	0.7	0.89
	1000	32.6	1.77	0.58	0.75	0.91	29.8	2.01	0.58	0.77	0.93	27	2.28	0.57	0.78	0.96	24.2	2.58	0.57	0.79	0.99
	1200	33.9	1.78	0.62	0.81	0.98	31.1	2.01	0.62	0.83	1	28.3	2.28	0.62	0.85	1	25.2	2.59	0.63	0.88	1
71°F	800	32.8	1.77	0.39	0.53	0.66	30.2	2.01	0.38	0.53	0.67	27.5	2.28	0.35	0.52	0.68	24.6	2.59	0.34	0.51	0.68
	1000	34.8	1.78	0.42	0.58	0.73	32.1	2.02	0.4	0.57	0.74	29.2	2.29	0.38	0.57	0.75	26.2	2.59	0.36	0.57	0.78
	1200	36.2	1.79	0.44	0.61	0.79	33.4	2.03	0.43	0.62	0.81	30.4	2.29	0.42	0.62	0.83	27.3	2.6	0.38	0.63	0.86

3 TON - KCA036S4

Entering Wet Bulb Temperature	Total Air Volume	Outdoor Air Temperature Entering Outdoor Coil																			
		85°F					95°F					105°F					115°F				
		Total Cool Cap.	Comp. Motor Input	Sensible To Total Ratio (S/T)			Total Cool Cap.	Comp. Motor Input	Sensible To Total Ratio (S/T)			Total Cool Cap.	Comp. Motor Input	Sensible To Total Ratio (S/T)			Total Cool Cap.	Comp. Motor Input	Sensible To Total Ratio (S/T)		
				Dry Bulb					Dry Bulb					Dry Bulb					Dry Bulb		
cfm	kBtuh	kW	75°F	80°F	85°F	kBtuh	kW	75°F	80°F	85°F	kBtuh	kW	75°F	80°F	85°F	kBtuh	kW	75°F	80°F	85°F	
63°F	960	35.6	2.35	0.75	0.87	0.98	33.4	2.67	0.75	0.89	1	31.1	3.04	0.77	0.91	1	28.5	3.48	0.79	0.93	1
	1200	37.7	2.36	0.8	0.93	1	35.3	2.68	0.81	0.95	1	32.9	3.06	0.82	0.98	1	30.2	3.49	0.84	1	1
	1440	39.3	2.37	0.84	0.98	1	36.8	2.69	0.85	1	1	34.5	3.07	0.87	1	1	32	3.5	0.9	1	1
67°F	960	37.6	2.36	0.59	0.72	0.84	35.4	2.68	0.59	0.73	0.86	33.1	3.05	0.59	0.74	0.88	30.4	3.5	0.59	0.76	0.9
	1200	39.8	2.38	0.62	0.78	0.91	37.5	2.7	0.62	0.79	0.92	34.9	3.07	0.63	0.8	0.94	32.1	3.5	0.64	0.82	0.97
	1440	41.4	2.39	0.65	0.82	0.96	38.9	2.71	0.66	0.84	0.98	36.2	3.08	0.66	0.86	1	33.3	3.51	0.68	0.88	1
71°F	960	39.9	2.38	0.45	0.58	0.7	37.5	2.7	0.44	0.58	0.71	34.9	3.07	0.42	0.58	0.72	32.2	3.5	0.43	0.58	0.74
	1200	42	2.39	0.45	0.61	0.75	39.5	2.71	0.46	0.61	0.77	36.9	3.09	0.45	0.62	0.79	34	3.52	0.45	0.63	0.81
	1440	43.6	2.41	0.47	0.65	0.8	41	2.73	0.46	0.65	0.82	38.2	3.1	0.47	0.66	0.83	35.2	3.53	0.47	0.68	0.87

4 TON - KCA048S4

Entering Wet Bulb Temperature	Total Air Volume	Outdoor Air Temperature Entering Outdoor Coil																			
		85°F					95°F					105°F					115°F				
		Total Cool Cap.	Comp. Motor Input	Sensible To Total Ratio (S/T)			Total Cool Cap.	Comp. Motor Input	Sensible To Total Ratio (S/T)			Total Cool Cap.	Comp. Motor Input	Sensible To Total Ratio (S/T)			Total Cool Cap.	Comp. Motor Input	Sensible To Total Ratio (S/T)		
				Dry Bulb					Dry Bulb					Dry Bulb					Dry Bulb		
cfm	kBtuh	kW	75°F	80°F	85°F	kBtuh	kW	75°F	80°F	85°F	kBtuh	kW	75°F	80°F	85°F	kBtuh	kW	75°F	80°F	85°F	
63°F	1280	47.6	3.02	0.74	0.87	0.98	44.5	3.44	0.74	0.88	1	41.2	3.89	0.75	0.9	1	37.8	4.41	0.77	0.93	1
	1600	50.4	3.04	0.79	0.93	1	47.1	3.46	0.8	0.95	1	43.7	3.91	0.81	0.97	1	40	4.42	0.83	1	1
	1920	52.6	3.05	0.83	0.99	1	49.1	3.47	0.85	1	1	45.7	3.93	0.87	1	1	42.3	4.45	0.89	1	1
67°F	1280	50.6	3.04	0.58	0.72	0.84	47.2	3.45	0.58	0.72	0.85	43.9	3.91	0.57	0.73	0.87	40.3	4.44	0.57	0.74	0.9
	1600	53.5	3.06	0.61	0.77	0.9	50	3.48	0.61	0.78	0.92	46.4	3.94	0.62	0.8	0.95	42.5	4.45	0.62	0.81	0.98
	1920	55.6	3.07	0.64	0.82	0.96	51.9	3.5	0.65	0.83	0.98	47.9	3.95	0.66	0.85	1	44	4.47	0.67	0.88	1
71°F	1280	53.7	3.06	0.43	0.57	0.69	50.2	3.48	0.43	0.57	0.7	46.6	3.93	0.42	0.57	0.71	42.8	4.46	0.41	0.57	0.72
	1600	56.4	3.07	0.45	0.6	0.75	52.6	3.5	0.45	0.6	0.76	49	3.96	0.44	0.61	0.78	45	4.48	0.43	0.62	0.8
	1920	58.6	3.08	0.47	0.64	0.8	54.8	3.52	0.47	0.64	0.81	50.8	3.98	0.46	0.65	0.83	46.7	4.5	0.45	0.66	0.86

RATINGS

NOTE - For Temperatures and Capacities not shown in tables, see bulletin - Cooling Unit Rating Table Correction Factor Data in Miscellaneous Engineering Data section.

5 TON - KCA060S4

Entering Wet Bulb Temperature	Total Air Volume	Outdoor Air Temperature Entering Outdoor Coil																			
		85°F					95°F					105°F					115°F				
		Total Cool Cap.	Comp. Motor Input	Sensible To Total Ratio (S/T) Dry Bulb			Total Cool Cap.	Comp. Motor Input	Sensible To Total Ratio (S/T) Dry Bulb			Total Cool Cap.	Comp. Motor Input	Sensible To Total Ratio (S/T) Dry Bulb			Total Cool Cap.	Comp. Motor Input	Sensible To Total Ratio (S/T) Dry Bulb		
				75°F	80°F	85°F			75°F	80°F	85°F			75°F	80°F	85°F			75°F	80°F	85°F
cfm	kBtuh	kW	75°F	80°F	85°F	kBtuh	kW	75°F	80°F	85°F	kBtuh	kW	75°F	80°F	85°F	kBtuh	kW	75°F	80°F	85°F	
63°F	1600	60.1	3.48	0.68	0.84	1	57	3.93	0.69	0.86	1	53.5	4.44	0.71	0.89	1	50	5.04	0.73	0.93	1
	2000	63.1	3.51	0.74	0.94	1	59.8	3.96	0.76	0.97	1	56	4.47	0.78	1	1	52.6	5.06	0.81	1	1
	2400	65.6	3.54	0.8	1	1	62.3	3.99	0.83	1	1	59.1	4.51	0.86	1	1	55.6	5.1	0.91	1	1
67°F	1600	63.9	3.52	0.54	0.66	0.79	60.5	3.97	0.54	0.67	0.82	57.1	4.48	0.55	0.69	0.85	53.2	5.07	0.56	0.71	0.89
	2000	66.8	3.55	0.57	0.72	0.9	63.1	4	0.58	0.73	0.93	59.2	4.51	0.58	0.75	0.97	55.1	5.1	0.59	0.79	1
	2400	68.9	3.58	0.6	0.78	0.99	65	4.02	0.61	0.8	1	61.1	4.54	0.63	0.84	1	56.8	5.12	0.64	0.88	1
71°F	1600	67.7	3.56	0.4	0.52	0.64	64.2	4.01	0.41	0.53	0.65	60.4	4.53	0.4	0.54	0.67	56.4	5.12	0.4	0.54	0.69
	2000	70.7	3.6	0.42	0.56	0.7	67	4.05	0.42	0.57	0.71	62.8	4.56	0.42	0.57	0.73	58.5	5.15	0.42	0.59	0.76
	2400	72.7	3.62	0.43	0.59	0.75	68.7	4.07	0.43	0.6	0.78	64.6	4.58	0.44	0.62	0.81	60	5.17	0.44	0.64	0.85

6 TON - KCA072S4

Entering Wet Bulb Temperature	Total Air Volume	Outdoor Air Temperature Entering Outdoor Coil																			
		85°F					95°F					105°F					115°F				
		Total Cool Cap.	Comp. Motor Input	Sensible To Total Ratio (S/T) Dry Bulb			Total Cool Cap.	Comp. Motor Input	Sensible To Total Ratio (S/T) Dry Bulb			Total Cool Cap.	Comp. Motor Input	Sensible To Total Ratio (S/T) Dry Bulb			Total Cool Cap.	Comp. Motor Input	Sensible To Total Ratio (S/T) Dry Bulb		
				75°F	80°F	85°F			75°F	80°F	85°F			75°F	80°F	85°F			75°F	80°F	85°F
cfm	kBtuh	kW	75°F	80°F	85°F	kBtuh	kW	75°F	80°F	85°F	kBtuh	kW	75°F	80°F	85°F	kBtuh	kW	75°F	80°F	85°F	
63°F	1920	70	4.55	0.68	0.83	0.99	66.6	5.06	0.7	0.86	1	62.8	5.63	0.71	0.89	1	58.5	6.28	0.73	0.92	1
	2400	73.8	4.57	0.74	0.93	1	70.1	5.07	0.76	0.96	1	66.1	5.64	0.78	0.99	1	61.8	6.29	0.8	1	1
	2880	76.6	4.57	0.8	1	1	73.1	5.08	0.82	1	1	69.6	5.65	0.85	1	1	65.6	6.31	0.89	1	1
67°F	1920	74.5	4.57	0.54	0.66	0.79	70.9	5.07	0.54	0.67	0.81	67	5.64	0.55	0.69	0.84	62.7	6.29	0.56	0.71	0.88
	2400	78.3	4.58	0.57	0.71	0.89	74.5	5.08	0.58	0.73	0.92	70.3	5.65	0.59	0.75	0.95	65.6	6.3	0.6	0.77	0.98
	2880	81.2	4.59	0.6	0.77	0.97	77	5.09	0.61	0.79	0.99	72.7	5.66	0.62	0.82	1	67.9	6.31	0.64	0.86	1
71°F	1920	79.1	4.59	0.41	0.53	0.64	75	5.08	0.41	0.53	0.65	71.1	5.66	0.4	0.53	0.66	66.6	6.3	0.41	0.54	0.68
	2400	83	4.6	0.42	0.56	0.69	79	5.1	0.42	0.57	0.7	74.5	5.67	0.42	0.58	0.72	69.9	6.32	0.42	0.59	0.75
	2880	85.9	4.61	0.44	0.59	0.74	81.7	5.11	0.44	0.6	0.77	77	5.67	0.44	0.61	0.79	72.3	6.33	0.44	0.63	0.83

7.5 TON - KCA090S4

Entering Wet Bulb Temperature	Total Air Volume	Outdoor Air Temperature Entering Outdoor Coil																			
		85°F					95°F					105°F					115°F				
		Total Cool Cap.	Comp. Motor Input	Sensible To Total Ratio (S/T) Dry Bulb			Total Cool Cap.	Comp. Motor Input	Sensible To Total Ratio (S/T) Dry Bulb			Total Cool Cap.	Comp. Motor Input	Sensible To Total Ratio (S/T) Dry Bulb			Total Cool Cap.	Comp. Motor Input	Sensible To Total Ratio (S/T) Dry Bulb		
				75°F	80°F	85°F			75°F	80°F	85°F			75°F	80°F	85°F			75°F	80°F	85°F
cfm	kBtuh	kW	75°F	80°F	85°F	kBtuh	kW	75°F	80°F	85°F	kBtuh	kW	75°F	80°F	85°F	kBtuh	kW	75°F	80°F	85°F	
63°F	2400	92.4	5.97	0.69	0.84	0.98	85.3	6.6	0.7	0.86	1	77.8	7.32	0.7	0.88	1	69.9	8.15	0.71	0.91	1
	3000	97.7	6.04	0.75	0.92	1	90.2	6.68	0.76	0.95	1	82.5	7.4	0.78	0.98	1	74.5	8.23	0.81	1	1
	3600	101.9	6.11	0.81	1	1	94.6	6.75	0.83	1	1	87.2	7.48	0.85	1	1	79.5	8.33	0.89	1	1
67°F	2400	99.4	6.07	0.54	0.67	0.81	91.8	6.7	0.53	0.68	0.83	84.2	7.43	0.53	0.68	0.85	75.9	8.26	0.52	0.7	0.88
	3000	104.5	6.15	0.57	0.73	0.89	96.8	6.78	0.58	0.74	0.91	88.7	7.51	0.57	0.76	0.95	79.9	8.34	0.58	0.79	0.99
	3600	108.5	6.21	0.61	0.79	0.97	100.2	6.84	0.62	0.81	0.99	92	7.57	0.62	0.84	1	82.7	8.39	0.62	0.87	1
71°F	2400	106.2	6.17	0.4	0.53	0.65	98.5	6.81	0.38	0.52	0.66	90.6	7.54	0.37	0.52	0.67	82.2	8.38	0.36	0.52	0.68
	3000	111.7	6.26	0.41	0.57	0.71	103.8	6.9	0.4	0.57	0.72	95.1	7.63	0.4	0.57	0.74	86.3	8.46	0.38	0.58	0.77
	3600	115.6	6.33	0.44	0.6	0.77	107.2	6.96	0.43	0.61	0.79	98.6	7.69	0.42	0.62	0.82	89	8.51	0.41	0.63	0.85

BLOWER DATA - DIRECT DRIVE - KCA024-030

BLOWER TABLE INCLUDES RESISTANCE FOR BASE UNIT ONLY WITH DRY INDOOR COIL AND AIR FILTERS IN PLACE.

FOR ALL UNITS ADD:

1 - Any factory installed options air resistance (economizer, wet coil, etc.) See page 28.

2 - Any field installed accessories air resistance (electric heat, duct resistance, diffuser, etc.) See page 28.

External Static Pressure (in. w.g.)	Air Volume (cfm) at Various Blower Speeds					
	208 VOLTS			230 VOLTS		
	High	Medium	Low	High	Medium	Low
2 and 2.5 Ton Standard Efficiency (Downflow)			KCA024S and KCA030S			
0.0	1199	928	838	1379	1085	877
0.1	1229	926	813	1409	1086	872
0.2	1206	928	782	1367	1094	850
0.3	1183	881	742	1350	1047	820
0.4	1159	843	686	1321	1009	783
0.5	1136	812	643	1282	981	762
0.6	1103	766	569	1242	921	705
0.7	1046	728	496	1195	888	625
0.8	953	648	432	1134	792	583
0.9	909	584	335	1037	738	492
1.0	783	465	247	926	592	411
2 and 2.5 Ton Standard Efficiency (Horizontal)			KCA024S and KCA030S			
0.0	1152	909	801	1325	1063	838
0.1	1152	893	770	1321	1048	826
0.2	1136	866	734	1288	1021	798
0.3	1104	826	697	1260	982	771
0.4	1072	787	643	1222	942	734
0.5	1041	747	589	1175	903	698
0.6	1009	707	534	1137	850	662
0.7	946	654	467	1081	797	588
0.8	861	588	396	1024	718	535
0.9	798	508	319	911	642	468
1.0	715	443	237	846	564	394

BLOWER DATA - DIRECT DRIVE - KCA036-048

BLOWER TABLE INCLUDES RESISTANCE FOR BASE UNIT ONLY WITH DRY INDOOR COIL AND AIR FILTERS IN PLACE.

FOR ALL UNITS ADD:

1 - Any factory installed options air resistance (economizer, wet coil, etc.) See page 28.

2 - Any field installed accessories air resistance (electric heat, duct resistance, diffuser, etc.) See page 28.

External Static Pressure (in. w.g.)	Air Volume (cfm) at Various Blower Speeds								
	208 VOLTS			230 VOLTS			460/575 VOLTS		
	High	Medium	Low	High	Medium	Low	High	Medium	Low
3 and 4 Ton Standard Efficiency (Downflow)					KCA036S and KCA048S				
0.0	1938	1552	1119	2167	1772	1317	2136	1716	1212
0.1	1992	1586	1128	2167	1780	1315	2104	1728	1208
0.2	1915	1592	1137	2100	1792	1307	2052	1684	1197
0.3	1865	1536	1083	2043	1735	1266	1994	1647	1172
0.4	1813	1495	1033	1986	1678	1204	1918	1597	1134
0.5	1762	1444	976	1909	1621	1164	1861	1534	1096
0.6	1694	1391	899	1814	1535	1082	1765	1485	1059
0.7	1609	1331	817	1718	1478	1000	1689	1410	996
0.8	1471	1220	730	1603	1364	918	1613	1335	920
0.9	1368	1066	522	1488	1250	755	1498	1235	848
1.0	1108	869	402	1259	1021	640	1345	1036	763
3 and 4 Ton Standard Efficiency (Horizontal)					KCA036S and KCA048S				
0.0	1862	1520	1070	2082	1736	1259	2085	1745	1247
0.1	1867	1530	1069	2031	1717	1246	2070	1744	1257
0.2	1804	1485	1067	1978	1672	1227	2016	1690	1225
0.3	1741	1440	1018	1907	1627	1190	1944	1643	1192
0.4	1677	1396	968	1837	1567	1128	1890	1596	1160
0.5	1614	1329	894	1749	1492	1066	1800	1533	1111
0.6	1550	1284	844	1660	1417	1016	1727	1455	1062
0.7	1455	1195	769	1554	1327	941	1655	1377	996
0.8	1329	1106	670	1448	1237	842	1511	1283	865
0.9	1202	927	496	1307	1087	718	1403	1190	784
1.0	1012	828	385	1025	973	613	1222	1002	670

BLOWER DATA - DIRECT DRIVE - KCA060

BLOWER TABLE INCLUDES RESISTANCE FOR BASE UNIT ONLY WITH DRY INDOOR COIL AND AIR FILTERS IN PLACE.

FOR ALL UNITS ADD:

1 - Any factory installed options air resistance (economizer, wet coil, etc.) See page 28.

2 - Any field installed accessories air resistance (electric heat, duct resistance, diffuser, etc.) See page 28.

External Static Pressure (in. w.g.)	Air Volume (cfm) at Various Blower Speeds					
	208 VOLTS		230 VOLTS		460/575 VOLTS	
	High	Low	High	Low	High	Low
5 Ton Standard Efficiency (Downflow)						KCA060S
0.0	2121	1644	2324	1952	2160	1750
0.1	2162	1660	2315	1991	2128	1733
0.2	2100	1704	2285	1946	2092	1712
0.3	2078	1667	2230	1928	2054	1687
0.4	2056	1646	2185	1909	2005	1652
0.5	2014	1626	2154	1873	1972	1629
0.6	1953	1592	2049	1821	1907	1583
0.7	1913	1594	1966	1787	1858	1549
0.8	1830	1519	1936	1715	1810	1515
0.9	1774	1509	1763	1650	1744	1469
1.0	1601	1319	1649	1508	1679	1400
5 Ton Standard Efficiency (Horizontal)						KCA060S
0.0	2038	1611	2222	1875	2225	1885
0.1	2026	1601	2194	1866	2236	1895
0.2	1978	1590	2145	1833	2186	1853
0.3	1940	1563	2096	1800	2137	1818
0.4	1902	1537	2047	1766	2106	1799
0.5	1845	1497	1973	1716	2031	1763
0.6	1787	1470	1924	1666	2002	1711
0.7	1730	1431	1850	1616	1970	1677
0.8	1653	1378	1776	1549	1853	1607
0.9	1558	1312	1677	1449	1800	1586
1.0	1462	1257	1579	1377	1750	1418

BLOWER DATA - BELT DRIVE - KCA036

BLOWER TABLE INCLUDES RESISTANCE FOR BASE UNIT ONLY WITH DRY INDOOR COIL AND AIR FILTERS IN PLACE.

FOR ALL UNITS ADD:

1 - Any factory installed options air resistance (economizer, wet coil, etc.) See page 28.

2 - Any field installed accessories air resistance (electric heat, duct resistance, diffuser, etc.) See page 28.

See page 28 for blower motors and drives and wet coil and options/accessory air resistance data.

DOWNFLOW

Air Volume cfm	External Static - in. w.g.															
	0.10		0.20		0.30		0.40		0.50		0.60		0.70		0.80	
	RPM	BHP	RPM	BHP	RPM	BHP	RPM	BHP	RPM	BHP	RPM	BHP	RPM	BHP	RPM	BHP
	Field Furnished						Drive Kit A01									
900	486	0.12	554	0.16	623	0.20	695	0.22	767	0.23	836	0.25	897	0.28	953	0.30
1000	508	0.15	576	0.19	643	0.22	713	0.24	783	0.26	848	0.28	907	0.30	961	0.33
1100	533	0.18	599	0.22	665	0.25	733	0.27	800	0.28	863	0.31	919	0.34	971	0.36
1200	560	0.21	625	0.25	689	0.28	755	0.30	820	0.32	879	0.34	932	0.37	983	0.40
1300	591	0.24	654	0.28	716	0.31	779	0.33	841	0.35	897	0.38	948	0.41	996	0.44
1400	631	0.26	690	0.30	748	0.34	807	0.36	864	0.39	916	0.42	964	0.46	1011	0.49
1500	676	0.28	729	0.33	782	0.36	835	0.40	887	0.43	935	0.47	981	0.50	1028	0.54

Air Volume cfm	External Static - in. w.g.															
	0.90		1.00		1.10		1.20		1.30		1.40		1.50		1.60	
	RPM	BHP	RPM	BHP	RPM	BHP	RPM	BHP	RPM	BHP	RPM	BHP	RPM	BHP	RPM	BHP
	Kit A01		Drive Kit A05													
900	1004	0.33	1055	0.35	1106	0.37	1152	0.40	1193	0.43	1232	0.46	1269	0.49	1305	0.52
1000	1011	0.36	1062	0.38	1111	0.41	1157	0.43	1199	0.47	1238	0.50	1276	0.53	1311	0.56
1100	1020	0.39	1070	0.41	1118	0.44	1163	0.47	1206	0.51	1245	0.54	1282	0.58	1318	0.61
1200	1031	0.43	1079	0.45	1127	0.48	1171	0.52	1213	0.55	1252	0.59	1289	0.62	1324	0.66
1300	1044	0.47	1091	0.49	1137	0.53	1181	0.56	1221	0.60	1259	0.64	1296	0.68	1330	0.71
1400	1058	0.51	1105	0.54	1150	0.57	1191	0.61	1231	0.65	1268	0.69	1303	0.73	1337	0.77
1500	1074	0.56	1120	0.59	1163	0.63	1203	0.67	1241	0.71	1277	0.75	1312	0.79	1345	0.82

HORIZONTAL

Air Volume cfm	External Static - in. w.g.															
	0.10		0.20		0.30		0.40		0.50		0.60		0.70		0.80	
	RPM	BHP	RPM	BHP	RPM	BHP	RPM	BHP	RPM	BHP	RPM	BHP	RPM	BHP	RPM	BHP
	Field Furnished						Drive Kit A01									
900	485	0.11	554	0.14	627	0.16	703	0.18	780	0.21	841	0.23	888	0.27	935	0.30
1000	509	0.13	578	0.16	649	0.19	722	0.21	796	0.23	854	0.26	900	0.29	947	0.33
1100	537	0.16	605	0.19	674	0.21	744	0.24	813	0.26	868	0.29	913	0.33	959	0.36
1200	567	0.19	633	0.22	700	0.24	768	0.27	833	0.30	884	0.33	928	0.37	974	0.40
1300	599	0.22	664	0.25	729	0.28	793	0.30	853	0.33	902	0.37	945	0.41	990	0.44
1400	634	0.26	697	0.29	758	0.31	819	0.34	875	0.38	921	0.42	964	0.46	1008	0.49
1500	669	0.30	730	0.33	789	0.36	846	0.39	897	0.42	941	0.47	983	0.51	1028	0.54

Air Volume cfm	External Static - in. w.g.															
	0.90		1.00		1.10		1.20		1.30		1.40		1.50		1.60	
	RPM	BHP	RPM	BHP	RPM	BHP	RPM	BHP	RPM	BHP	RPM	BHP	RPM	BHP	RPM	BHP
	Kit A01		Kit A05													
900	986	0.32	1039	0.35	1090	0.37	1137	0.40	1177	0.43	1214	0.46	1248	0.49	1280	0.51
1000	997	0.35	1048	0.38	1098	0.41	1143	0.44	1184	0.47	1221	0.50	1255	0.53	1287	0.56
1100	1008	0.39	1059	0.41	1107	0.44	1150	0.47	1191	0.51	1228	0.54	1263	0.57	1295	0.60
1200	1022	0.43	1071	0.45	1117	0.48	1160	0.52	1200	0.55	1237	0.59	1271	0.62	1303	0.66
1300	1037	0.47	1085	0.50	1130	0.53	1171	0.57	1210	0.60	1246	0.64	1280	0.68	1312	0.71
1400	1054	0.52	1100	0.54	1144	0.58	1183	0.62	1221	0.66	1256	0.70	1290	0.73	1321	0.77
1500	1073	0.57	1117	0.60	1159	0.64	1197	0.67	1234	0.71	1268	0.75	1301	0.79	1332	0.83

BLOWER DATA - BELT DRIVE - KCA048

BLOWER TABLE INCLUDES RESISTANCE FOR BASE UNIT ONLY WITH DRY INDOOR COIL AND AIR FILTERS IN PLACE.

FOR ALL UNITS ADD:

1 - Any factory installed options air resistance (economizer, wet coil, etc.) See page 28.

2 - Any field installed accessories air resistance (electric heat, duct resistance, diffuser, etc.) See page 28.

See page 28 for blower motors and drives and wet coil and options/accessory air resistance data.

DOWNFLOW

Air Volume cfm	External Static - in. w.g.															
	0.10		0.20		0.30		0.40		0.50		0.60		0.70		0.80	
	RPM	BHP	RPM	BHP	RPM	BHP	RPM	BHP	RPM	BHP	RPM	BHP	RPM	BHP	RPM	BHP
	Field Furnished						Drive Kit A02									
1200	560	0.21	625	0.25	689	0.28	755	0.30	820	0.32	879	0.34	932	0.37	983	0.40
1300	591	0.24	654	0.28	716	0.31	779	0.33	841	0.35	897	0.38	948	0.41	996	0.44
1400	631	0.26	690	0.30	748	0.34	807	0.36	864	0.39	916	0.42	964	0.46	1011	0.49
1500	675	0.28	729	0.33	782	0.36	835	0.40	887	0.43	935	0.47	981	0.50	1028	0.54
1600	718	0.31	766	0.35	814	0.40	862	0.44	910	0.48	955	0.52	1000	0.55	1046	0.59
1700	756	0.34	799	0.39	843	0.44	887	0.49	932	0.53	976	0.57	1020	0.61	1066	0.64
1800	787	0.40	828	0.45	870	0.50	912	0.55	955	0.59	999	0.63	1043	0.67	1089	0.70
1900	815	0.46	855	0.51	897	0.57	939	0.62	981	0.66	1024	0.69	1068	0.73	1113	0.76
2000	843	0.53	884	0.59	925	0.64	968	0.68	1009	0.72	1052	0.76	1095	0.79	1138	0.83

Air Volume cfm	External Static - in. w.g.															
	0.90		1.00		1.10		1.20		1.30		1.40		1.50		1.60	
	RPM	BHP	RPM	BHP	RPM	BHP	RPM	BHP	RPM	BHP	RPM	BHP	RPM	BHP	RPM	BHP
	Drive Kit A02						Drive Kit A06									
1200	1031	0.43	1079	0.45	1127	0.48	1171	0.52	1213	0.55	1252	0.59	1289	0.62	1324	0.66
1300	1044	0.47	1091	0.49	1137	0.53	1181	0.56	1221	0.60	1259	0.64	1296	0.68	1330	0.71
1400	1058	0.51	1105	0.54	1150	0.57	1191	0.61	1231	0.65	1268	0.69	1303	0.73	1337	0.77
1500	1074	0.56	1120	0.59	1163	0.63	1203	0.67	1241	0.71	1277	0.75	1312	0.79	1345	0.82
1600	1092	0.61	1137	0.65	1178	0.68	1216	0.72	1253	0.76	1288	0.80	1321	0.84	1354	0.88
1700	1112	0.67	1155	0.70	1193	0.75	1230	0.79	1265	0.83	1299	0.87	1332	0.91	1364	0.95
1800	1133	0.73	1174	0.77	1209	0.81	1244	0.85	1278	0.90	1311	0.94	1343	0.98	1375	1.02
1900	1156	0.80	1193	0.84	1226	0.89	1260	0.93	1293	0.97	1325	1.01	1356	1.06	1388	1.10
2000	1178	0.87	1213	0.92	1243	0.97	1275	1.02	1307	1.06	1339	1.10	1370	1.14	1402	1.18

HORIZONTAL

Air Volume cfm	External Static - in. w.g.															
	0.10		0.20		0.30		0.40		0.50		0.60		0.70		0.80	
	RPM	BHP	RPM	BHP	RPM	BHP	RPM	BHP	RPM	BHP	RPM	BHP	RPM	BHP	RPM	BHP
	Field Furnished						Drive Kit A02									
1200	567	0.19	633	0.22	700	0.24	768	0.27	833	0.30	884	0.33	928	0.37	974	0.40
1300	599	0.22	664	0.25	729	0.28	793	0.30	853	0.33	902	0.37	945	0.41	990	0.44
1400	634	0.26	697	0.29	758	0.31	819	0.34	875	0.38	921	0.42	964	0.46	1008	0.49
1500	669	0.30	730	0.33	789	0.36	846	0.39	897	0.42	941	0.47	983	0.51	1028	0.54
1600	705	0.34	763	0.37	819	0.40	873	0.43	921	0.48	963	0.52	1004	0.56	1048	0.59
1700	741	0.38	796	0.41	850	0.45	900	0.49	945	0.53	985	0.58	1026	0.62	1070	0.65
1800	776	0.43	829	0.46	880	0.51	927	0.55	970	0.60	1009	0.64	1050	0.68	1093	0.71
1900	812	0.48	862	0.52	910	0.57	955	0.62	996	0.66	1035	0.71	1076	0.74	1118	0.78
2000	847	0.54	895	0.59	941	0.64	984	0.69	1023	0.74	1062	0.78	1103	0.81	1144	0.85

Air Volume cfm	External Static - in. w.g.															
	0.90		1.00		1.10		1.20		1.30		1.40		1.50		1.60	
	RPM	BHP	RPM	BHP	RPM	BHP	RPM	BHP	RPM	BHP	RPM	BHP	RPM	BHP	RPM	BHP
	Drive Kit A02						Drive Kit A06									
1200	1022	0.43	1071	0.45	1117	0.48	1160	0.52	1200	0.55	1237	0.59	1271	0.62	1303	0.66
1300	1037	0.47	1085	0.50	1130	0.53	1171	0.57	1210	0.60	1246	0.64	1280	0.68	1312	0.71
1400	1054	0.52	1100	0.54	1144	0.58	1183	0.62	1221	0.66	1256	0.70	1290	0.73	1321	0.77
1500	1073	0.57	1117	0.60	1159	0.64	1197	0.67	1234	0.71	1268	0.75	1301	0.79	1332	0.83
1600	1093	0.62	1136	0.66	1175	0.70	1212	0.74	1247	0.78	1281	0.82	1313	0.86	1344	0.90
1700	1114	0.68	1155	0.72	1192	0.76	1227	0.80	1262	0.85	1295	0.89	1327	0.93	1358	0.97
1800	1136	0.75	1175	0.79	1210	0.83	1245	0.88	1278	0.92	1311	0.97	1342	1.01	1373	1.05
1900	1159	0.82	1197	0.86	1229	0.92	1263	0.97	1296	1.01	1328	1.06	1359	1.10	1390	1.14
2000	1183	0.90	1218	0.95	1249	1.01	1282	1.06	1314	1.11	1346	1.15	1377	1.20	1408	1.24

BLOWER DATA - BELT DRIVE - KCA060

BLOWER TABLE INCLUDES RESISTANCE FOR BASE UNIT ONLY WITH DRY INDOOR COIL AND AIR FILTERS IN PLACE.

FOR ALL UNITS ADD:

1 - Any factory installed options air resistance (economizer, wet coil, etc.) See page 28.

2 - Any field installed accessories air resistance (electric heat, duct resistance, diffuser, etc.) See page 28.

See page 28 for blower motors and drives and wet coil and options/accessory air resistance data.

DOWNFLOW

Air Volume cfm	External Static - in. w.g.															
	0.10		0.20		0.30		0.40		0.50		0.60		0.70		0.80	
	RPM	BHP	RPM	BHP	RPM	BHP	RPM	BHP	RPM	BHP	RPM	BHP	RPM	BHP	RPM	BHP
	Field Furnished						Drive Kit A03									
1600	738	0.32	785	0.36	831	0.41	878	0.45	923	0.49	969	0.53	1014	0.57	1061	0.59
1700	773	0.36	816	0.41	859	0.46	903	0.51	947	0.55	991	0.58	1036	0.62	1082	0.65
1800	803	0.42	844	0.47	886	0.52	929	0.57	972	0.61	1016	0.64	1060	0.68	1106	0.71
1900	831	0.48	872	0.54	915	0.59	957	0.63	1000	0.67	1043	0.71	1087	0.74	1131	0.78
2000	861	0.56	903	0.61	945	0.66	988	0.70	1030	0.74	1072	0.77	1115	0.81	1157	0.85
2100	893	0.63	935	0.69	978	0.73	1019	0.78	1060	0.81	1101	0.85	1143	0.89	1182	0.93
2200	927	0.71	969	0.76	1011	0.81	1052	0.85	1091	0.89	1131	0.93	1170	0.97	1206	1.02
2300	963	0.79	1004	0.84	1045	0.89	1084	0.93	1122	0.97	1159	1.02	1195	1.07	1228	1.13
2400	999	0.88	1039	0.92	1078	0.97	1115	1.02	1151	1.06	1186	1.12	1219	1.18	1250	1.24

Air Volume cfm	External Static - in. w.g.															
	0.90		1.00		1.10		1.20		1.30		1.40		1.50		1.60	
	RPM	BHP	RPM	BHP	RPM	BHP	RPM	BHP	RPM	BHP	RPM	BHP	RPM	BHP	RPM	BHP
	Drive Kit A03								Drive Kit A07							
1600	1107	0.62	1151	0.66	1190	0.70	1228	0.74	1264	0.78	1298	0.82	1332	0.86	1364	0.90
1700	1128	0.68	1169	0.72	1206	0.76	1242	0.80	1277	0.84	1310	0.88	1343	0.92	1375	0.96
1800	1150	0.74	1189	0.79	1223	0.83	1257	0.87	1291	0.91	1324	0.95	1356	0.99	1388	1.03
1900	1173	0.81	1208	0.86	1240	0.91	1273	0.95	1306	0.99	1338	1.03	1369	1.07	1401	1.12
2000	1195	0.89	1228	0.94	1257	0.99	1290	1.04	1321	1.08	1353	1.12	1384	1.16	1416	1.20
2100	1217	0.98	1247	1.04	1275	1.09	1306	1.14	1338	1.18	1369	1.22	1400	1.25	1432	1.29
2200	1238	1.08	1265	1.14	1293	1.19	1324	1.24	1355	1.28	1387	1.31	1418	1.35	1450	1.39
2300	1257	1.19	1284	1.25	1313	1.30	1344	1.34	1375	1.38	1406	1.41	1437	1.45	1470	1.48
2400	1278	1.30	1305	1.36	1334	1.40	1364	1.44	1395	1.48	1427	1.51	1458	1.55	1492	1.58

HORIZONTAL

Air Volume cfm	External Static - in. w.g.															
	0.10		0.20		0.30		0.40		0.50		0.60		0.70		0.80	
	RPM	BHP	RPM	BHP	RPM	BHP	RPM	BHP	RPM	BHP	RPM	BHP	RPM	BHP	RPM	BHP
	Field Furnished						Drive Kit A03									
1600	752	0.30	798	0.35	844	0.40	889	0.45	933	0.49	975	0.53	1018	0.57	1062	0.60
1700	785	0.35	827	0.40	871	0.46	914	0.51	957	0.55	999	0.59	1042	0.63	1085	0.66
1800	813	0.42	855	0.47	898	0.52	940	0.57	983	0.62	1025	0.66	1067	0.69	1110	0.72
1900	841	0.49	883	0.54	926	0.60	969	0.65	1011	0.69	1052	0.72	1094	0.76	1136	0.79
2000	871	0.56	914	0.62	957	0.67	1000	0.72	1040	0.76	1081	0.79	1122	0.83	1162	0.87
2100	903	0.64	946	0.70	990	0.75	1031	0.79	1071	0.83	1110	0.87	1150	0.91	1189	0.96
2200	937	0.73	981	0.78	1023	0.83	1063	0.87	1102	0.91	1140	0.96	1178	1.01	1215	1.07
2300	973	0.81	1015	0.86	1056	0.91	1095	0.96	1132	1.01	1170	1.06	1206	1.12	1242	1.19
2400	1010	0.91	1051	0.96	1090	1.01	1127	1.06	1164	1.11	1200	1.18	1235	1.24	1269	1.31

Air Volume cfm	External Static - in. w.g.															
	0.90		1.00		1.10		1.20		1.30		1.40		1.50		1.60	
	RPM	BHP	RPM	BHP	RPM	BHP	RPM	BHP	RPM	BHP	RPM	BHP	RPM	BHP	RPM	BHP
	Drive Kit A03								Drive Kit A07							
1600	1107	0.63	1149	0.67	1187	0.71	1223	0.75	1258	0.79	1291	0.83	1323	0.87	1354	0.91
1700	1129	0.69	1169	0.73	1204	0.78	1240	0.82	1274	0.86	1306	0.90	1338	0.95	1369	0.99
1800	1152	0.76	1190	0.80	1223	0.85	1258	0.90	1291	0.94	1323	0.99	1354	1.03	1385	1.07
1900	1176	0.83	1212	0.89	1243	0.94	1277	0.99	1309	1.03	1341	1.08	1372	1.12	1402	1.16
2000	1201	0.92	1234	0.98	1264	1.04	1296	1.09	1329	1.13	1360	1.18	1391	1.22	1422	1.26
2100	1225	1.02	1256	1.08	1285	1.14	1318	1.19	1349	1.24	1381	1.28	1412	1.32	1442	1.36
2200	1249	1.13	1279	1.19	1308	1.25	1340	1.30	1372	1.34	1403	1.38	1434	1.42	1465	1.46
2300	1273	1.25	1303	1.31	1332	1.36	1364	1.41	1396	1.45	1427	1.49	1458	1.53	1490	1.57
2400	1300	1.37	1329	1.43	1359	1.47	1390	1.52	1422	1.56	1453	1.60	1484	1.64	1516	1.67

BLOWER DATA - BELT DRIVE - KCA072 - DOWNFLOW

BLOWER TABLE INCLUDES RESISTANCE FOR BASE UNIT ONLY WITH DRY INDOOR COIL AND AIR FILTERS IN PLACE.

FOR ALL UNITS ADD:

1 - Any factory installed options air resistance (economizer, wet coil, etc.) See page 28.

2 - Any field installed accessories air resistance (electric heat, duct resistance, diffuser, etc.) See page 28.

See page 28 for blower motors and drives and wet coil and options/accessory air resistance data.

Air Volume cfm	External Static - in. w.g.															
	0.10		0.20		0.30		0.40		0.50		0.60		0.70		0.80	
	RPM	BHP	RPM	BHP	RPM	BHP	RPM	BHP	RPM	BHP	RPM	BHP	RPM	BHP	RPM	BHP
	Field Furnished										Drive Kit A04					
1900	826	0.36	859	0.41	894	0.45	928	0.50	964	0.56	1000	0.61	1036	0.66	1072	0.70
2000	857	0.42	889	0.47	920	0.52	952	0.57	986	0.62	1020	0.68	1055	0.73	1091	0.77
2100	878	0.49	909	0.54	940	0.59	973	0.64	1006	0.70	1041	0.75	1076	0.80	1112	0.85
2200	897	0.55	929	0.61	961	0.66	994	0.72	1028	0.78	1063	0.83	1099	0.89	1134	0.93
2300	918	0.62	950	0.68	983	0.74	1017	0.80	1052	0.86	1087	0.92	1122	0.97	1157	1.02
2400	941	0.70	974	0.77	1008	0.83	1042	0.90	1077	0.96	1111	1.01	1146	1.06	1181	1.11
2500	966	0.79	1000	0.86	1034	0.93	1068	1.00	1103	1.06	1137	1.11	1171	1.16	1205	1.20
2600	994	0.90	1028	0.97	1062	1.04	1096	1.10	1130	1.16	1164	1.21	1197	1.26	1231	1.30
2700	1023	1.01	1057	1.08	1091	1.15	1125	1.22	1159	1.27	1192	1.32	1225	1.37	1258	1.41
2800	1053	1.13	1088	1.21	1122	1.27	1155	1.33	1188	1.39	1221	1.43	1253	1.48	1286	1.53
2900	1085	1.26	1119	1.33	1153	1.40	1186	1.45	1218	1.51	1250	1.55	1281	1.61	1313	1.66

Air Volume cfm	External Static - in. w.g.															
	0.90		1.00		1.10		1.20		1.30		1.40		1.50		1.60	
	RPM	BHP	RPM	BHP	RPM	BHP	RPM	BHP	RPM	BHP	RPM	BHP	RPM	BHP	RPM	BHP
	Drive Kit A04														Kit A08	
1900	1109	0.75	1146	0.79	1183	0.82	1221	0.86	1260	0.90	1294	0.94	1323	0.98	1349	1.02
2000	1128	0.82	1164	0.86	1201	0.89	1239	0.93	1276	0.97	1310	1.01	1336	1.06	1362	1.10
2100	1148	0.89	1185	0.93	1221	0.97	1258	1.01	1294	1.05	1325	1.09	1351	1.14	1376	1.19
2200	1170	0.97	1206	1.01	1242	1.05	1277	1.09	1311	1.14	1341	1.18	1365	1.23	1390	1.28
2300	1193	1.06	1228	1.09	1262	1.14	1295	1.19	1327	1.24	1355	1.29	1380	1.33	1406	1.37
2400	1216	1.15	1250	1.19	1282	1.24	1313	1.30	1343	1.36	1371	1.40	1396	1.44	1423	1.48
2500	1240	1.24	1273	1.29	1302	1.36	1331	1.42	1360	1.48	1388	1.52	1414	1.55	1441	1.58
2600	1265	1.34	1296	1.40	1324	1.47	1352	1.54	1381	1.60	1408	1.64	1434	1.67	1460	1.70
2700	1291	1.46	1321	1.52	1347	1.60	1374	1.67	1403	1.72	1429	1.76	1455	1.79	1481	1.82
2800	1317	1.58	1346	1.66	1372	1.74	1399	1.80	1426	1.85	1451	1.89	1477	1.92	1503	1.95
2900	1343	1.72	1371	1.80	1397	1.88	1424	1.95	1450	1.99	1475	2.02	1500	2.05	1526	2.08

BLOWER DATA - BELT DRIVE - KCA072 - HORIZONTAL

BLOWER TABLE INCLUDES RESISTANCE FOR BASE UNIT ONLY WITH DRY INDOOR COIL AND AIR FILTERS IN PLACE.

FOR ALL UNITS ADD:

1 - Any factory installed options air resistance (economizer, wet coil, etc.) See page 28.

2 - Any field installed accessories air resistance (electric heat, duct resistance, diffuser, etc.) See page 28.

See page 28 for blower motors and drives and wet coil and options/accessory air resistance data.

Air Volume cfm	External Static - in. w.g.															
	0.10		0.20		0.30		0.40		0.50		0.60		0.70		0.80	
	RPM	BHP	RPM	BHP	RPM	BHP	RPM	BHP	RPM	BHP	RPM	BHP	RPM	BHP	RPM	BHP
	Field Furnished								Drive Kit A04							
1900	853	0.41	886	0.46	919	0.50	952	0.55	986	0.60	1021	0.64	1056	0.69	1091	0.73
2000	883	0.48	913	0.53	944	0.57	976	0.62	1009	0.67	1043	0.71	1078	0.76	1112	0.80
2100	906	0.56	936	0.60	967	0.65	999	0.70	1033	0.75	1067	0.79	1101	0.84	1135	0.88
2200	930	0.64	960	0.68	991	0.73	1024	0.78	1058	0.83	1092	0.88	1126	0.92	1160	0.96
2300	954	0.72	985	0.77	1017	0.82	1051	0.87	1085	0.92	1119	0.96	1152	1.00	1186	1.04
2400	981	0.81	1013	0.86	1046	0.91	1079	0.96	1113	1.00	1146	1.05	1180	1.09	1213	1.13
2500	1010	0.91	1042	0.96	1075	1.00	1109	1.05	1142	1.09	1175	1.14	1207	1.18	1239	1.23
2600	1040	1.01	1073	1.05	1106	1.10	1139	1.14	1171	1.19	1203	1.23	1235	1.28	1266	1.33
2700	1072	1.10	1104	1.15	1137	1.20	1169	1.24	1201	1.29	1232	1.34	1263	1.40	1293	1.46
2800	1105	1.21	1137	1.25	1168	1.30	1200	1.35	1231	1.40	1261	1.46	1291	1.52	1321	1.59
2900	1138	1.32	1169	1.37	1200	1.42	1231	1.47	1261	1.53	1291	1.60	1321	1.66	1350	1.73

Air Volume cfm	External Static - in. w.g.															
	0.90		1.00		1.10		1.20		1.30		1.40		1.50		1.60	
	RPM	BHP	RPM	BHP	RPM	BHP	RPM	BHP	RPM	BHP	RPM	BHP	RPM	BHP	RPM	BHP
	Drive Kit A04														Kit A08	
1900	1126	0.77	1163	0.81	1200	0.85	1237	0.88	1273	0.92	1306	0.96	1339	1.00	1371	1.04
2000	1148	0.84	1183	0.88	1220	0.92	1257	0.96	1291	1.00	1323	1.04	1354	1.08	1385	1.12
2100	1170	0.92	1206	0.96	1242	1.00	1277	1.04	1310	1.08	1340	1.13	1371	1.17	1401	1.21
2200	1195	1.00	1230	1.04	1265	1.08	1299	1.13	1330	1.18	1359	1.23	1388	1.27	1418	1.31
2300	1220	1.08	1254	1.13	1288	1.17	1320	1.23	1350	1.28	1378	1.34	1406	1.38	1435	1.42
2400	1245	1.18	1278	1.22	1311	1.28	1341	1.33	1370	1.40	1397	1.45	1425	1.50	1454	1.54
2500	1271	1.28	1303	1.33	1334	1.39	1363	1.45	1391	1.52	1418	1.57	1446	1.62	1474	1.66
2600	1297	1.39	1328	1.45	1357	1.52	1385	1.58	1412	1.64	1439	1.70	1467	1.74	1495	1.78
2700	1323	1.52	1353	1.58	1382	1.65	1409	1.72	1435	1.77	1462	1.82	1490	1.86	1517	1.90
2800	1351	1.65	1380	1.72	1407	1.78	1434	1.85	1460	1.90	1486	1.95	1513	1.99	1541	2.02
2900	1379	1.79	1407	1.86	1434	1.92	1460	1.98	1485	2.04	1511	2.08	1538	2.12	1565	2.15

BLOWER DATA - BELT DRIVE - KCA090 - DOWNFLOW

BLOWER TABLE INCLUDES RESISTANCE FOR BASE UNIT ONLY WITH DRY INDOOR COIL AND AIR FILTERS IN PLACE.

FOR ALL UNITS ADD:

1 - Any factory installed options air resistance (economizer, wet coil, etc.) See page 28.

2 - Any field installed accessories air resistance (electric heat, duct resistance, diffuser, etc.) See page 28.

See page 28 for blower motors and drives and wet coil and options/accessory air resistance data.

Air Volume cfm	External Static - in. w.g.																			
	0.10		0.20		0.30		0.40		0.50		0.60		0.70		0.80		0.90		1.00	
	RPM	BHP	RPM	BHP	RPM	BHP	RPM	BHP	RPM	BHP	RPM	BHP	RPM	BHP	RPM	BHP	RPM	BHP	RPM	BHP
	Drive Kit AA01																Drive Kit AA02			
2400	553	0.65	585	0.71	617	0.78	649	0.85	680	0.91	711	0.98	740	1.04	769	1.10	796	1.15	821	1.21
2500	570	0.71	602	0.78	633	0.84	665	0.91	695	0.97	725	1.04	753	1.10	781	1.16	807	1.22	832	1.27
2600	588	0.77	619	0.84	650	0.91	680	0.97	710	1.04	739	1.10	767	1.16	793	1.22	818	1.28	842	1.33
2700	607	0.84	637	0.91	667	0.97	697	1.04	726	1.11	753	1.17	780	1.23	806	1.29	830	1.35	854	1.40
2800	626	0.91	655	0.97	684	1.04	713	1.11	741	1.18	768	1.24	794	1.30	819	1.36	842	1.42	866	1.47
2900	646	0.98	674	1.05	702	1.11	730	1.18	757	1.25	783	1.32	808	1.38	832	1.44	855	1.49	878	1.54
3000	666	1.06	693	1.12	721	1.19	747	1.26	774	1.33	799	1.40	823	1.46	846	1.52	868	1.57	891	1.62
3100	686	1.14	713	1.21	739	1.28	765	1.35	790	1.41	814	1.48	838	1.55	860	1.61	882	1.66	904	1.70
3200	707	1.22	732	1.29	758	1.36	783	1.43	807	1.50	830	1.57	853	1.64	874	1.70	896	1.75	918	1.79
3300	727	1.31	752	1.38	776	1.46	800	1.53	823	1.60	846	1.67	868	1.73	889	1.79	911	1.84	932	1.89
3400	747	1.41	771	1.48	794	1.55	817	1.63	840	1.70	862	1.77	883	1.83	904	1.89	925	1.94	947	1.98
3500	767	1.51	790	1.58	812	1.66	835	1.73	856	1.80	878	1.87	899	1.93	920	1.99	940	2.04	961	2.08
3600	786	1.61	808	1.69	830	1.77	852	1.84	873	1.91	894	1.98	915	2.04	935	2.09	955	2.14	975	2.19
Air Volume cfm	External Static - in. w.g.																			
	0.90		1.00		1.30		1.40		1.50		1.60		1.70		1.80		1.90		2.00	
	RPM	BHP	RPM	BHP	RPM	BHP	RPM	BHP	RPM	BHP	RPM	BHP	RPM	BHP	RPM	BHP	RPM	BHP	RPM	BHP
	Drive Kit AA02				Drive Kit AA03															
2400	846	1.25	870	1.29	895	1.33	920	1.37	947	1.41	972	1.45	996	1.50	1018	1.55	1039	1.61	1059	1.67
2500	856	1.31	880	1.35	905	1.39	930	1.43	956	1.47	980	1.52	1003	1.57	1024	1.63	1044	1.69	1064	1.76
2600	866	1.38	891	1.42	915	1.46	940	1.50	965	1.54	988	1.59	1010	1.65	1031	1.71	1050	1.78	1069	1.84
2700	878	1.44	902	1.48	926	1.52	950	1.57	974	1.61	997	1.67	1018	1.73	1037	1.80	1056	1.87	1075	1.93
2800	889	1.51	913	1.55	937	1.59	961	1.64	984	1.69	1006	1.75	1026	1.82	1044	1.89	1063	1.96	1081	2.03
2900	902	1.58	925	1.63	949	1.67	972	1.72	994	1.78	1015	1.84	1034	1.91	1052	1.99	1069	2.06	1087	2.13
3000	914	1.66	938	1.71	961	1.75	983	1.81	1004	1.87	1024	1.94	1042	2.01	1059	2.09	1076	2.16	1093	2.23
3100	927	1.75	950	1.79	972	1.84	994	1.90	1014	1.96	1033	2.04	1050	2.11	1067	2.19	1083	2.27	1100	2.34
3200	941	1.84	963	1.88	984	1.94	1005	2.00	1024	2.07	1042	2.14	1059	2.23	1075	2.31	1091	2.39	1107	2.46
3300	954	1.93	976	1.98	996	2.04	1016	2.10	1035	2.18	1052	2.26	1067	2.35	1083	2.43	1098	2.51	1114	2.59
3400	968	2.03	989	2.08	1008	2.14	1027	2.22	1045	2.30	1061	2.38	1076	2.47	1091	2.57	1106	2.65	1121	2.73
3500	982	2.13	1001	2.19	1020	2.26	1038	2.33	1054	2.42	1070	2.51	1084	2.61	1099	2.71	1113	2.79	1128	2.87
3600	995	2.24	1014	2.30	1031	2.38	1048	2.46	1064	2.55	1079	2.65	1093	2.76	1107	2.86	1121	2.95	1136	3.03
Drive Kit - AA03				Drive Kit - AA04																

BLOWER DATA - BELT DRIVE - KCA090 - HORIZONTAL

BLOWER TABLE INCLUDES RESISTANCE FOR BASE UNIT ONLY WITH DRY INDOOR COIL AND AIR FILTERS IN PLACE.

FOR ALL UNITS ADD:

1 - Any factory installed options air resistance (economizer, wet coil, etc.) See page 28.

2 - Any field installed accessories air resistance (electric heat, duct resistance, diffuser, etc.) See page 28.

See page 28 for blower motors and drives and wet coil and options/accessory air resistance data.

Air Volume cfm	External Static - in. w.g.																			
	0.10		0.20		0.30		0.40		0.50		0.60		0.70		0.80		0.90		1.00	
	RPM	BHP	RPM	BHP	RPM	BHP	RPM	BHP	RPM	BHP	RPM	BHP	RPM	BHP	RPM	BHP	RPM	BHP	RPM	BHP
	Drive Kit AA01										Drive Kit AA02									
2400	596	0.79	626	0.82	657	0.85	688	0.89	718	0.92	749	0.96	778	1.01	806	1.06	833	1.11	858	1.16
2500	616	0.85	645	0.88	676	0.91	706	0.95	736	0.99	765	1.03	794	1.08	821	1.13	847	1.18	871	1.23
2600	636	0.91	665	0.94	695	0.98	724	1.02	754	1.06	782	1.10	809	1.15	836	1.20	861	1.25	885	1.30
2700	657	0.97	685	1.01	714	1.04	743	1.08	771	1.13	799	1.17	826	1.22	851	1.27	875	1.32	899	1.37
2800	677	1.03	706	1.07	734	1.11	762	1.16	790	1.20	816	1.25	842	1.30	867	1.35	890	1.40	913	1.45
2900	698	1.10	726	1.14	754	1.19	781	1.23	808	1.28	834	1.33	859	1.38	883	1.43	906	1.48	928	1.54
3000	720	1.17	747	1.22	774	1.26	801	1.31	826	1.36	851	1.41	876	1.46	899	1.52	921	1.57	943	1.63
3100	741	1.25	768	1.30	794	1.35	820	1.40	845	1.45	869	1.50	893	1.56	915	1.61	937	1.67	959	1.73
3200	763	1.34	789	1.39	815	1.44	840	1.49	864	1.54	888	1.60	910	1.66	932	1.72	954	1.78	975	1.84
3300	785	1.43	811	1.48	836	1.53	860	1.59	883	1.65	906	1.71	928	1.77	950	1.83	970	1.90	991	1.96
3400	807	1.53	832	1.58	856	1.64	880	1.70	903	1.76	925	1.82	946	1.88	967	1.95	987	2.02	1007	2.09
3500	830	1.63	854	1.69	877	1.75	900	1.81	922	1.88	944	1.94	964	2.01	985	2.08	1004	2.15	1024	2.23
3600	852	1.74	876	1.81	898	1.87	921	1.94	942	2.01	963	2.07	983	2.15	1002	2.22	1022	2.29	1041	2.37
Air Volume cfm	External Static - in. w.g.																			
	0.90		1.00		1.30		1.40		1.50		1.60		1.70		1.80		1.90		2.00	
	RPM	BHP	RPM	BHP	RPM	BHP	RPM	BHP	RPM	BHP	RPM	BHP	RPM	BHP	RPM	BHP	RPM	BHP	RPM	BHP
	Drive Kit AA03																			
2400	883	1.21	907	1.25	931	1.30	955	1.35	979	1.40	1003	1.45	1027	1.51	1050	1.57	1072	1.63	1094	1.69
2500	895	1.28	919	1.32	942	1.37	966	1.42	990	1.48	1013	1.53	1036	1.59	1059	1.65	1081	1.71	1102	1.78
2600	908	1.35	931	1.40	955	1.45	978	1.50	1001	1.56	1024	1.62	1046	1.68	1068	1.74	1089	1.80	1110	1.87
2700	922	1.43	945	1.48	967	1.53	990	1.59	1013	1.65	1035	1.71	1056	1.77	1078	1.84	1099	1.90	1119	1.96
2800	936	1.51	958	1.56	980	1.62	1003	1.68	1025	1.74	1046	1.80	1067	1.87	1088	1.93	1109	2.00	1129	2.06
2900	950	1.60	972	1.66	994	1.72	1016	1.78	1037	1.84	1058	1.91	1079	1.97	1099	2.04	1119	2.11	1139	2.17
3000	965	1.69	986	1.76	1008	1.82	1029	1.88	1050	1.95	1070	2.02	1091	2.08	1110	2.15	1130	2.22	1149	2.28
3100	980	1.80	1001	1.86	1022	1.93	1043	2.00	1063	2.07	1083	2.13	1103	2.20	1122	2.27	1141	2.33	1160	2.40
3200	995	1.91	1016	1.98	1036	2.05	1057	2.12	1077	2.19	1096	2.26	1116	2.33	1134	2.39	1153	2.46	1171	2.52
3300	1011	2.03	1031	2.11	1051	2.18	1071	2.25	1091	2.32	1110	2.39	1129	2.45	1147	2.52	1165	2.59	1183	2.65
3400	1027	2.16	1047	2.24	1067	2.31	1086	2.38	1105	2.45	1124	2.52	1142	2.59	1160	2.66	1178	2.72	1196	2.78
3500	1043	2.30	1063	2.38	1082	2.45	1101	2.52	1120	2.59	1138	2.66	1156	2.73	1174	2.80	1191	2.86	1208	2.92
3600	1060	2.45	1079	2.52	1098	2.60	1117	2.67	1135	2.74	1153	2.81	1170	2.87	1188	2.94	1205	3.00	1222	3.06
	Drive Kit AA04																			

BLOWER DATA

BELT DRIVE KIT SPECIFICATIONS

Model No.	Blower Motor Choice (HP)						Drive Kit No.	RPM Range
	Nominal	Maximum	Nominal	Maximum	Nominal	Maximum		
036	1	1.15	1.5	1.7	2	2.3	A01	673 - 1010 rpm
							A05	897 - 1346 rpm
048	1	1.15	1.5	1.7	2	2.3	A02	745 - 1117 rpm
							A06	1071 - 1429 rpm
060	1	1.15	1.5	1.7	2	2.3	A03	833 - 1250 rpm
							A07	1212 - 1548 rpm
072	1	1.15	---	---	2	2.3	A04	968 - 1340 rpm
							A08	1193 - 1591 rpm
090	1	1.15	---	---	---	---	AA01	522 - 784 rpm
	2	2.3	---	---	---	---	AA02	632 - 875 rpm
	3	3.45	---	---	---	---	AA03	798 - 1105 rpm
							AA04	921 - 1228 rpm

NOTE - Using total air volume and system static pressure requirements determine from blower performance tables rpm and motor hp required. Maximum usable hp of motors furnished are shown. In Canada, nominal motor hp is also maximum usable motor hp. If motors of comparable hp are used, be sure to keep within the service factor limitations outlined on the motor nameplate.

OPTIONS / ACCESSORIES AIR RESISTANCE FOR 024-072 MODELS - in. w.g.

Air Volume cfm	Wet Indoor Coil			Economizer	Electric Heat	Filters	
	036-048	060	072			MERV 8	MERV 13
800	0.01	0.01	0.01	0.04	0.01	0.04	0.05
1000	0.02	0.02	0.01	0.04	0.03	0.04	0.07
1200	0.03	0.04	0.02	0.04	0.06	0.04	0.07
1400	0.04	0.05	0.03	0.04	0.09	0.04	0.07
1600	0.05	0.06	0.04	0.04	0.12	0.04	0.07
1800	0.06	0.07	0.05	0.05	0.15	0.05	0.07
2000	0.08	0.09	0.06	0.05	0.18	0.05	0.08
2200	0.09	0.10	0.07	0.05	0.20	0.05	0.08
2400	0.10	0.12	0.08	0.05	0.22	0.05	0.08
2600	0.11	0.13	0.09	0.06	0.24	0.05	0.08
2800	0.13	0.15	0.10	0.06	0.26	0.05	0.08
3000	0.14	0.16	0.12	0.06	0.28	0.05	0.08

OPTIONS / ACCESSORIES AIR RESISTANCE FOR 090 MODELS - in. w.g.

Air Volume cfm	Wet Indoor Coil	Economizer	Electric Heat	Filters	
				MERV 8	MERV 13
2400	0.08	0.05	0.22	0.05	0.08
2600	0.09	0.06	0.24	0.05	0.08
2800	0.10	0.06	0.26	0.05	0.08
3000	0.11	0.06	0.28	0.05	0.08
3200	0.12	0.06	0.30	0.06	0.09
3400	0.14	0.06	0.32	0.06	0.09
3600	0.15	0.06	0.34	0.06	0.10

POWER EXHAUST FAN PERFORMANCE

Return Air System Static Pressure - in. w.g.	Air Volume Exhausted cfm
0.00	2000
0.05	1990
0.10	1924
0.15	1810
0.20	1664
0.25	1507
0.30	1350
0.35	1210

BLOWER DATA

CEILING DIFFUSERS AIR RESISTANCE (in. w.g.)

Air Volume cfm	RTD9-65 Step-Down Diffuser			FD9-65 Flush Diffuser	RTD11-95 Step-Down Diffuser			FD11-95 Flush Diffuser
	2 Ends Open	1 Side & 2 Ends Open	All Ends & Sides Open		2 Ends Open	1 Side & 2 Ends Open	All Ends & Sides Open	
800	0.15	0.13	0.11	0.11	---	---	---	---
1000	0.19	0.16	0.14	0.14	---	---	---	---
1200	0.25	0.20	0.17	0.17	---	---	---	---
1400	0.33	0.26	0.20	0.20	---	---	---	---
1600	0.43	0.32	0.20	0.24	---	---	---	---
1800	0.56	0.40	0.30	0.30	0.13	0.11	0.09	0.09
2000	0.73	0.50	0.36	0.36	0.15	0.13	0.11	0.10
2200	0.95	0.63	0.44	0.44	0.18	0.15	0.12	0.12
2400	---	----	---	---	0.21	0.18	0.15	0.14
2600	---	----	---	---	0.24	0.21	0.18	0.17
2800	---	----	---	---	0.27	0.24	0.21	0.20
3000	---	----	---	---	0.32	0.29	0.25	0.25
3200	---	----	---	---	0.41	0.37	0.32	0.31
3400	---	----	---	---	0.50	0.45	0.39	0.37
3600	---	----	---	---	0.61	0.54	0.48	0.44

CEILING DIFFUSER AIR THROW DATA

Air Volume - cfm	¹ Effective Throw - ft.	
Model No.	RTD9-65	FD9-65
800	10 - 17	14 - 18
1000	10 - 17	15 - 20
1200	11 - 18	16 - 22
1400	12 - 19	17 - 24
1600	12 - 20	18 - 25
1800	13 - 21	20 - 28
2000	14 - 23	21 - 29
2200	16 - 25	22 - 30
Model No.	RTD11-95	FD11-95
2600	24 - 29	19 - 24
2800	25 - 30	20 - 28
3000	27 - 33	21 - 29
3200	28 - 35	22 - 29
3400	30 - 37	22 - 30
3600	25 - 33	22 - 24

¹ Effective throw based on terminal velocities of 75 ft. per minute.

ELECTRICAL/ELECTRIC HEAT DATA**2 - 2.5 TON**

DIRECT DRIVE BLOWER		KCA024S	KCA030S
¹ Voltage - 60hz		208/230V - 1 Ph	208/230V - 1 Ph
Compressor 1	Rated Load Amps	13.5	14.1
	Locked Rotor Amps	58.3	73
Outdoor Fan Motors (1)	Full Load Amps (total)	1.7	1.7
Service Outlet 115V GFI (amps)		15	15
Indoor Blower Motor	Horsepower	.25	.25
	Full Load Amps	1.8	1.8
² Maximum Overcurrent Protection	Unit Only	30	35
³ Minimum Circuit Ampacity	Unit Only	21	22

ELECTRIC HEAT DATA

Electric Heat Voltage			208V	240V	208V	240V
² Maximum Overcurrent Protection	Unit + Electric Heat	7.5 kW	40	45	40	45
		10 kW	50	60	50	60
³ Minimum Circuit Ampacity	Unit + Electric Heat	7.5 kW	37	42	37	42
		10 kW	48	55	48	55

ELECTRICAL ACCESSORIES

Disconnect	Standard Access - 0-10 kW	20W15	20W15	20W15	20W15
	Hinged Access - 0-10 kW	20W21	20W21	20W21	20W21

NOTE - All units have a minimum Short Circuit Current Rating (SCCR) of 5000 amps.

¹ Extremes of operating range are plus and minus 10% of line voltage.² HACR type breaker or fuse.³ Refer to National or Canadian Electrical Code manual to determine wire, fuse and disconnect size requirements.

ELECTRICAL/ELECTRIC HEAT DATA

3 TON

KCA036S

¹ Voltage - 60hz		208/230V - 1 Ph			208/230V - 3 Ph			460V - 3 Ph			575V - 3 Ph		
Compressor	Rated Load Amps	16.7			10.4			5.8			3.8		
	Locked Rotor Amps	79			73			38			36.5		
Outdoor Fan Motors (1)	Full Load Amps (total)	1.7			1.7			1.1			0.7		
Power Exhaust (1) 0.33 HP	Full Load Amps (total)	2.4			2.4			1.3			1		
Service Outlet 115V GFI (amps)		15			15			15			20		
Indoor Blower Motor	Horsepower	.5	1.5	.5	1	2	.5	1	2	.5	1	2	
	Full Load Amps	3.9	11	3.9	4.6	7.5	2	2.1	3.4	2	1.7	2.7	
² Maximum Overcurrent Protection	Unit Only	40	50	25	25	30	15	15	15	15	15	15	
	with (1) 0.33 HP Power Exhaust	45	50	30	30	35	15	15	15	15	15	15	
³ Minimum Circuit Ampacity	Unit Only	27	34	19	20	23	11	11	12	8	8	9	
	with (1) 0.33 HP Power Exhaust	29	36	21	22	25	12	12	14	9	9	10	

ELECTRIC HEAT DATA

Electric Heat Voltage			208V	240V	208V	240V	208V	240V	208V	240V	208V	240V	480V	480V	480V	600V	600V	600V
² Maximum Overcurrent Protection	Unit + 7.5 kW	Electric Heat	40	45	50	60	25	30	30	30	30	35	15	15	20	15	15	15
		15 kW	80	90	90	100	45	50	45	60	50	60	30	30	30	25	25	25
³ Minimum Circuit Ampacity	Unit + 7.5 kW	Electric Heat	39	44	48	53	25	28	26	29	29	32	14	14	16	12	12	13
		15 kW	73	83	82	92	44	50	45	51	49	55	26	26	27	21	21	22
² Maximum Overcurrent Protection	Unit + 7.5 kW	Electric Heat + Power Exhaust	45	50	60	60	30	35	30	35	35	35	20	20	20	15	15	15
		15 kW	80	90	90	100	50	60	50	60	60	60	30	30	30	25	25	25
³ Minimum Circuit Ampacity	Unit + 7.5 kW	Electric Heat + Power Exhaust	42	47	51	56	28	31	29	32	32	35	16	16	18	13	13	14
		15 kW	76	87	85	95	47	53	48	54	52	58	27	27	29	22	22	23

ELECTRICAL ACCESSORIES

Disconnect	Standard Access - 0-7.5 kW	20W15	20W15	20W15	20W15	20W15	20W15	20W15
		15 kW	20W16	20W16	20W15	20W15	20W15	20W15
	Hinged Access - 0-7.5 kW	20W21	20W21	20W21	20W21	20W21	20W21	20W21
		15 kW	20W22	20W22	20W21	20W21	20W21	20W21

NOTE - All units have a minimum Short Circuit Current Rating (SCCR) of 5000 amps.

¹ Extremes of operating range are plus and minus 10% of line voltage.

² HACR type breaker or fuse.

³ Refer to National or Canadian Electrical Code manual to determine wire, fuse and disconnect size requirements.

ELECTRICAL/ELECTRIC HEAT DATA

4 TON

KCA048S

¹ Voltage - 60hz		208/230V - 1 Ph			208/230V - 3 Ph			460V - 3 Ph			575V - 3 Ph		
Compressor	Rated Load Amps	21.8			13.7			6.2			4.8		
	Locked Rotor Amps	117			83.1			41			33		
Outdoor Fan Motors (1)	Full Load Amps (total)	1.7			1.7			1.1			0.7		
Power Exhaust (1) 0.33 HP	Full Load Amps (total)	2.4			2.4			1.3			1		
Service Outlet 115V GFI (amps)		15			15			15			20		
Indoor Blower Motor	Horsepower	.5	1.5	.5	1	2	.5	1	2	.5	1	2	
	Full Load Amps	3.9	11	3.9	4.6	7.5	2	2.1	3.4	2	1.7	2.7	
² Maximum Overcurrent Protection	Unit Only	50	60	35	35	40	15	15	15	15	15	15	
	with (1) 0.33 HP Power Exhaust	50	60	35	35	40	15	15	15	15	15	15	
³ Minimum Circuit Ampacity	Unit Only	33	40	23	24	27	11	11	13	9	9	10	
	with (1) 0.33 HP Power Exhaust	36	43	26	26	29	13	13	14	10	10	11	

ELECTRIC HEAT DATA

Electric Heat Voltage			208V	240V	208V	240V	208V	240V	208V	240V	208V	240V	480V	480V	480V	600V	600V	600V
² Maximum Overcurrent Protection	Unit + 7.5 kW	Electric Heat	50	50	60	60	35	35	35	35	40	40	15	15	20	15	15	15
	Unit + 15 kW	Electric Heat	80	90	90	100	45	50	45	60	50	60	30	30	30	25	25	25
³ Minimum Circuit Ampacity	Unit + 7.5 kW	Electric Heat	39	44	48	53	25	28	26	29	29	32	14	14	16	12	12	13
	Unit + 15 kW	Electric Heat	73	83	82	92	44	50	45	51	49	55	26	26	27	21	21	22
² Maximum Overcurrent Protection	Unit + 7.5 kW	Electric Heat + Power Exhaust	50	50	60	60	35	35	35	35	40	40	20	20	20	15	15	15
	Unit + 15 kW	Electric Heat + Power Exhaust	80	90	90	100	50	60	50	60	60	60	30	30	30	25	25	25
³ Minimum Circuit Ampacity	Unit + 7.5 kW	Electric Heat + Power Exhaust	42	47	51	56	28	31	29	32	32	35	16	16	18	13	13	14
	Unit + 15 kW	Electric Heat + Power Exhaust	76	87	85	95	47	53	48	54	52	58	27	27	29	22	22	23

ELECTRICAL ACCESSORIES

Disconnect	Standard Access - 0-7.5 kW	20W15	20W15	20W15	20W15	20W15	20W15
		15 kW	20W16	20W16	20W15	20W15	20W15
	Hinged Access - 0-7.5 kW	20W21	20W21	20W21	20W21	20W21	20W21
		15 kW	20W22	20W22	20W21	20W21	20W21

NOTE - All units have a minimum Short Circuit Current Rating (SCCR) of 5000 amps.

¹ Extremes of operating range are plus and minus 10% of line voltage.

² HACR type breaker or fuse.

³ Refer to National or Canadian Electrical Code manual to determine wire, fuse and disconnect size requirements.

ELECTRICAL/ELECTRIC HEAT DATA

5 TON

KCA060S

¹ Voltage - 60hz		208/230V - 1 Ph			208/230V - 3 Ph			460V - 3 Ph			575V - 3 Ph		
Compressor	Rated Load Amps	22.1			13.5			8			5		
	Locked Rotor Amps	125			109			59			40		
Outdoor Fan Motors (1)	Full Load Amps (total)	2.4			2.4			1.3			1		
Power Exhaust (1) 0.33 HP	Full Load Amps (total)	2.4			2.4			1.3			1		
Service Outlet 115V GFI (amps)		15			15			15			20		
Indoor Blower Motor	Horsepower	.75	1.5	.75	1	2	.75	1	2	.75	1	2	
	Full Load Amps	4.9	11	4.9	4.6	7.5	2.5	2.1	3.4	2.5	1.7	2.7	
² Maximum Overcurrent Protection	Unit Only	50	60	35	35	40	20	20	20	15	15	15	
	with (1) 0.33 HP Power Exhaust	50	60	40	35	40	20	20	20	15	15	15	
³ Minimum Circuit Ampacity	Unit Only	35	42	25	24	27	14	14	15	10	9	10	
	with (1) 0.33 HP Power Exhaust	38	44	27	27	30	16	15	16	11	10	11	

ELECTRIC HEAT DATA

Electric Heat Voltage			208V	240V	208V	240V	208V	240V	208V	240V	208V	240V	480V	480V	480V	600V	600V	600V
² Maximum Overcurrent Protection	Unit + 7.5 kW	Electric Heat	50	50	60	60	35	35	35	35	40	40	20	20	20	15	15	15
	15 kW		80	90	90	100	50	60	45	60	50	60	30	30	30	25	25	25
	22.5 kW		110	125	125	150	70	80	70	80	70	80	40	40	40	35	30	35
³ Minimum Circuit Ampacity	Unit + 7.5 kW	Electric Heat	40	46	48	53	26	29	26	29	29	32	15	14	16	13	12	13
	15 kW		74	85	82	92	46	52	45	51	49	55	26	26	27	22	21	22
	22.5 kW		108	124	116	131	65	74	65	74	69	78	37	37	39	31	30	31
² Maximum Overcurrent Protection	Unit + 7.5 kW	Electric Heat + Power Exhaust	50	50	60	60	40	40	35	35	40	40	20	20	20	15	15	15
	15 kW		80	90	90	100	50	60	50	60	60	60	30	30	30	25	25	25
	22.5 kW		125	150	125	150	70	80	70	80	80	90	40	40	40	35	35	35
³ Minimum Circuit Ampacity	Unit + 7.5 kW	Electric Heat + Power Exhaust	43	49	51	56	29	32	29	32	32	35	17	16	18	14	13	14
	15 kW		77	88	85	95	49	55	48	54	52	58	28	27	29	23	22	23
	22.5 kW		111	127	119	134	68	77	68	77	72	81	39	39	40	32	31	32

ELECTRICAL ACCESSORIES

Disconnect	Standard Access - 0-7.5 kW	20W15	20W15	20W15	20W15	20W15	20W15	20W15
		15-22.5 kW	20W16	20W16	20W15	20W15	20W15	20W15
	Hinged Access - 0-7.5 kW	20W21	20W21	20W21	20W21	20W21	20W21	20W21
		15-22.5 kW	20W22	20W22	20W21	20W21	20W21	20W21

NOTE - All units have a minimum Short Circuit Current Rating (SCCR) of 5000 amps.

¹ Extremes of operating range are plus and minus 10% of line voltage.

² HACR type breaker or fuse.

³ Refer to National or Canadian Electrical Code manual to determine wire, fuse and disconnect size requirements.

ELECTRICAL/ELECTRIC HEAT DATA
6 TON
KCA072S

¹ Voltage - 60hz		208/230V - 3 Ph		460V - 3 Ph		575V - 3 Ph	
Compressor	Rated Load Amps	19		9.7		7.4	
	Locked Rotor Amps	123		62		50	
Outdoor Fan Motors (1)	Full Load Amps (total)	2.4		1.3		1	
Power Exhaust (1) 0.33 HP	Full Load Amps (total)	2.4		1.3		1	
Service Outlet 115V GFI (amps)		15		15		20	
Indoor Blower Motor	Horsepower	1	2	1	2	1	2
	Full Load Amps	4.6	7.5	2.1	3.4	1.7	2.7
² Maximum Overcurrent Protection	Unit Only	45	50	25	25	15	20
	with (1) 0.33 HP Power Exhaust	50	50	25	25	20	20
³ Minimum Circuit Ampacity	Unit Only	31	34	16	17	12	13
	with (1) 0.33 HP Power Exhaust	34	37	17	19	13	14

ELECTRIC HEAT DATA

Electric Heat Voltage			208V	240V	208V	240V	480V	480V	600V	600V
² Maximum Overcurrent Protection	Unit + Electric Heat	7.5 kW	45	45	50	50	25	25	15	20
		15 kW	45	60	50	60	30	30	25	25
		22.5 kW	70	80	70	80	40	40	30	35
		30 kW	90	100	90	100	50	50	40	40
³ Minimum Circuit Ampacity	Unit + Electric Heat	7.5 kW	31	31	34	34	16	17	12	13
		15 kW	45	51	49	55	26	27	21	22
		22.5 kW	65	74	69	78	37	39	30	31
		30 kW	84	96	88	100	48	50	39	40
² Maximum Overcurrent Protection	Unit + Electric Heat + Power Exhaust	7.5 kW	50	50	50	50	25	25	20	20
		15 kW	50	60	60	60	30	30	25	25
		22.5 kW	70	80	80	90	40	40	35	35
		30 kW	90	100	100	110	50	60	40	45
³ Minimum Circuit Ampacity	Unit + Electric Heat + Power Exhaust	7.5 kW	34	34	37	37	17	19	13	14
		15 kW	48	54	52	58	27	29	22	23
		22.5 kW	68	77	72	81	39	40	31	32
		30 kW	87	99	91	103	50	51	40	41

ELECTRICAL ACCESSORIES

Disconnect	Standard Access - 0-22.5 kW	20W18	20W18	20W18	20W18
		30 kW	20W19	20W19	20W18
	Hinged Access - 0-22.5 kW	20W24	20W24	20W24	20W24
		30 kW	20W25	20W25	20W24

NOTE - All units have a minimum Short Circuit Current Rating (SCCR) of 5000 amps.

¹ Extremes of operating range are plus and minus 10% of line voltage.

² HACR type breaker or fuse.

³ Refer to National or Canadian Electrical Code manual to determine wire, fuse and disconnect size requirements.

ELECTRICAL/ELECTRIC HEAT DATA

7.5 TON

KCA090S

¹ Voltage - 60hz		208/230V - 3 Ph			460V - 3 Ph			575V - 3 Ph		
Compressor	Rated Load Amps	25			12.2			9		
	Locked Rotor Amps	164			100			78		
Outdoor Fan Motors (1)	Full Load Amps (total)	2.4			1.3			1		
Power Exhaust (1) 0.33 HP	Full Load Amps (total)	2.4			1.3			1		
Service Outlet 115V GFI (amps)		15			15			20		
Indoor Blower Motor	Horsepower	1	2	3	1	2	3	1	2	3
	Full Load Amps	4.6	7.5	10.6	2.1	3.4	4.8	1.7	2.7	3.9
² Maximum Overcurrent Protection	Unit Only	60	60	60	30	30	30	20	20	25
	with (1) 0.33 HP Power Exhaust	60	60	70	30	30	30	20	20	25
³ Minimum Circuit Ampacity	Unit Only	39	42	45	19	20	22	14	15	17
	with (1) 0.33 HP Power Exhaust	41	44	47	20	22	23	15	16	18

ELECTRIC HEAT DATA

Electric Heat Voltage				208V	240V	208V	240V	208V	240V	480V	480V	480V	600V	600V	600V
² Maximum Overcurrent Protection	Unit + Electric Heat	7.5 kW	7.5 kW	60	60	60	60	60	60	30	30	30	20	20	25
		15 kW	15 kW	60	60	60	60	60	60	30	30	30	25	25	25
		22.5 kW	22.5 kW	70	80	70	80	80	90	40	40	40	30	35	35
		30 kW	30 kW	90	100	90	100	100	110	50	50	60	40	40	45
³ Minimum Circuit Ampacity	Unit + Electric Heat	7.5 kW	7.5 kW	39	39	42	42	45	45	19	20	22	14	15	17
		15 kW	15 kW	45	51	49	55	53	59	26	27	29	21	22	23
		22.5 kW	22.5 kW	65	74	69	78	72	81	37	39	40	30	31	32
		30 kW	30 kW	84	96	88	100	92	104	48	50	52	39	40	41
² Maximum Overcurrent Protection	Unit + Electric Heat + Power Exhaust	7.5 kW	7.5 kW	60	60	60	60	70	70	30	30	30	20	20	25
		15 kW	15 kW	60	60	60	60	70	70	30	30	35	25	25	25
		22.5 kW	22.5 kW	70	80	80	90	80	90	40	40	45	35	35	35
		30 kW	30 kW	90	100	100	110	100	110	50	60	60	40	45	45
³ Minimum Circuit Ampacity	Unit + Electric Heat + Power Exhaust	7.5 kW	7.5 kW	41	41	44	44	47	47	20	22	23	15	16	18
		15 kW	15 kW	48	54	52	58	56	62	27	29	31	22	23	25
		22.5 kW	22.5 kW	68	77	72	81	75	84	39	40	42	31	32	34
		30 kW	30 kW	87	99	91	103	95	107	50	51	53	40	41	43

ELECTRICAL ACCESSORIES

Disconnect	Standard Access - 0-22.5 kW	20W18	20W18	20W18	20W18	20W18
		30 kW	20W19	20W19	20W19	20W18
	Hinged Access - 0-22.5 kW	20W24	20W24	20W24	20W24	20W24
		30 kW	20W25	20W25	20W25	20W24

NOTE - All units have a minimum Short Circuit Current Rating (SCCR) of 5000 amps.

¹ Extremes of operating range are plus and minus 10% of line voltage.

² HACR type breaker or fuse.

³ Refer to National or Canadian Electrical Code manual to determine wire, fuse and disconnect size requirements.

ELECTRIC HEAT CAPACITIES

Input Voltage	7.5 kW			10 kW			15 kW			22.5 kW			30 kW		
	No of Stages	kW input	Btuh Output	No of Stages	kW input	Btuh Output	No of Stages	kW input	Btuh Output	No of Stages	kW input	Btuh Output	No of Stages	kW input	Btuh Output
208	1	5.6	19,200	1	7.5	25,600	1	11.2	38,400	1	16.9	57,700	1	22.5	76,800
220	1	6.3	21,500	1	8.4	28,700	1	12.6	43,000	1	18.9	64,500	1	25.2	86,000
230	1	6.9	23,500	1	9.2	31,400	1	13.8	47,000	1	20.7	70,700	1	27.5	93,900
240	1	7.5	25,600	1	10.0	34,200	1	15.0	51,200	1	22.5	76,800	1	30.0	102,400
440	1	6.3	21,500	---	---	---	1	12.6	43,000	1	18.9	64,500	1	25.2	86,000
460	1	6.9	23,500	---	---	---	1	13.8	47,000	1	20.7	70,700	1	27.5	93,900
480	1	7.5	25,600	---	---	---	1	15.0	51,200	1	22.5	76,800	1	30.0	102,400
550	1	6.3	21,500	---	---	---	1	12.6	43,000	1	18.9	64,500	1	25.2	86,000
575	1	6.9	23,500	---	---	---	1	13.8	47,000	1	20.7	70,700	1	27.5	93,900
600	1	7.5	25,600	---	---	---	1	15.0	51,200	1	22.5	76,800	1	30.0	102,400

UNIT CLEARANCES - INCHES (MM)

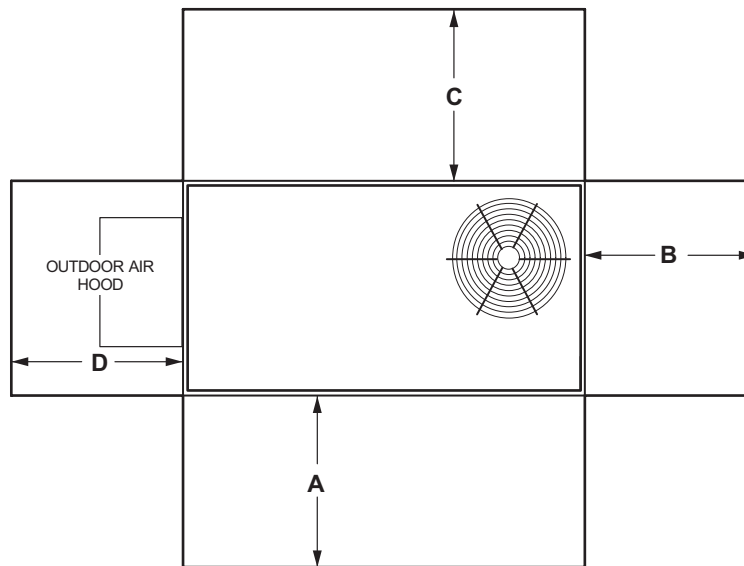

¹ Unit Clearance	A		B		C		D		Top Clearance
	in.	mm	in.	mm	in.	mm	in.	mm	
Service Clearance	36	914	36	914	36	914	36	914	Unobstructed
Minimum Operation Clearance	36	914	36	914	36	914	36	914	

NOTE - Entire perimeter of unit base requires support when elevated above the mounting surface.

¹ Service Clearance - Required for removal of serviceable parts.

Minimum Operation Clearance - Required clearance for proper unit operation.

OPTIONAL CONVENTIONAL TEMPERATURE CONTROL SYSTEMS - FIELD INSTALLED

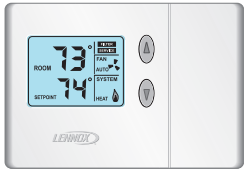
Item	Model No.	Catalog No.
COMMERCIAL TOUCHSCREEN THERMOSTAT		
 <ul style="list-style-type: none"> Two-Stage Heating / Two-Stage Cooling Conventional or Heat Pump Intuitive Touchscreen Interface Seven-Day Programmable Four Time Periods Per Day Economizer Output Title 24 Compliant Backlit Display Automatic Changeover 	C0STAT02AE1L	14W81
Sensors For Touchscreen Thermostat		
¹ Remote non-adjustable wall mount 20k temperature sensor	C0SNZN01AE2-	47W36
¹ Remote non-adjustable wall mount 10k averaging temperature sensor	C0SNZN73AE1-	47W37
¹ Remote non-adjustable duct mount temperature sensor	C0SNDC00AE1-	19L22
Outdoor temperature sensor	C0SNSR03AE1-	X4148
<small>¹ Remote sensors for C0STAT02AE1L can be applied in the following combinations: (1) C0SNZN01AE1-, (2) C0SNZN73AE1-, (2) C0SNZN01AE1- and (1) C0SNZN73AE1-, (4) C0SNZN01AE1-, (3) C0SNZN01AE1- and (2) C0SNZN73AE1.</small>		
Accessories For Touchscreen Thermostat		
Locking cover (clear)	COMISC15AE1-	39P21
DIGITAL NON-PROGRAMMABLE THERMOSTATS		
 <ul style="list-style-type: none"> One-Stage Heating / Cooling Conventional Systems Intuitive Interface Automatic Changeover Backlit Display Simple Up and Down Temperature Control. 	C0STAT12AE1L	51M32
Sensor For Digital Non-Programmable Thermostat		
Outdoor temperature sensor	C0SNSR04AE1-	X2658
Accessories For Digital Non-Programmable Thermostat		
Optional wall mounting plate	COMISC17AE1-	X2659

OUTDOOR SOUND DATA

Unit Model No.	Octave Band Linear Sound Power Levels dB, re 10 ⁻¹² Watts - Center Frequency - Hz							¹ Sound Rating Number (SRN) (dBA)
	125	250	500	1000	2000	4000	8000	
024, 030, 036 and 048	63	66	70	71	68	62	53	75
060 and 072	67	72	77	76	73	68	61	82
090	66	71	73	74	70	65	57	79

Note - The octave sound power data does not include tonal corrections.

¹ Sound Rating Number according to ARI Standard 270-95 (includes pure tone penalty). "SRN" is the overall A-Weighted Sound Power Level, (LWA), dB (100 Hz to 10,000 Hz).

WEIGHT DATA

Model Number	Net				Shipping			
	Base		Max.		Base		Max.	
	lbs.	kg	lbs.	kg	lbs.	kg	lbs.	kg
024S	495	225	607	275	555	252	676	307
030S	497	225	609	276	557	253	678	308
036S	498	226	610	277	558	253	679	308
048S	535	243	647	293	595	270	716	325
060S	565	256	681	309	625	283	750	340
072S	664	301	767	348	724	328	839	381
090S	745	334	851	386	805	365	920	417

Base Unit - The unit with NO OPTIONS.

Max. Unit - The unit with ALL OPTIONS installed (Economizer, etc.).

OPTIONS / ACCESSORIES

	Shipping Weights		
	lbs.	kg	
ECONOMIZER / OUTDOOR AIR / POWER EXHAUST			
Economizer			
Economizer - Includes Barometric Relief Dampers and Exhaust Hood	131	59	
Outdoor Air Dampers			
Motorized	25	12	
Manual	18	9	
Power Exhaust			
Standard Static	35	17	
ELECTRIC HEAT			
7.5 kW	31	14	
10 kW	31	14	
15 kW	31	14	
22.5 kW	35	16	
30 kW	35	16	
ROOF CURBS			
Hybrid Roof Curbs, Downflow			
8 in. height	50	23	
14 in. height	70	32	
18 in. height	80	36	
24 in. height	100	45	
Clip Curbs, Full Perimeter, Downflow			
8 in. height	83	38	
14 in. height	101	46	
18 in. height	113	51	
24 in. height	131	59	
Hinged, Full Perimeter, Downflow			
8 in. height	83	38	
18 in. height	113	49	
24 in. height	131	59	
Standard, Full Perimeter, Downflow			
14 in. height	101	46	
CEILING DIFFUSERS			
Step-Down	RTD9-65	67	30
	RTD11-95	88	40
Flush	FD9-65	37	17
	FD11-95	75	34
Transitions (Supply and Return)	T1TRAN10AN1	22	10
	T1TRAN20N-1	21	10

DIMENSIONS - INCHES (MM)

Model No.	CORNER WEIGHTS								CENTER OF GRAVITY							
	AA		BB		CC		DD		EE		FF		FF			
	Base lbs. kg	Max. lbs. kg	Base lbs. kg	Max. lbs. kg	Base lbs. kg	Max. lbs. kg	Base lbs. kg	Max. lbs. kg	Base in. mm	Max. in. mm	Base in. mm	Max. in. mm	Base in. mm	Max. in. mm		
024	86 39	109 50	104 47	123 56	167 76	199 90	138 63	176 80	38-1/2 978	40 1016	18 457	18 457	18 457	18 457		
030	86 39	109 50	104 47	124 56	168 76	199 91	138 63	176 80	38-1/2 978	40 1016	18 457	18 457	18 457	18 457		
036	86 39	110 50	105 48	124 56	169 77	200 91	139 63	177 80	38-1/2 978	40 1016	18 457	18 457	18 457	18 457		
048	93 42	116 53	112 51	132 60	181 82	212 96	149 68	187 85	38-1/2 978	40 1016	18 457	18 457	18 457	18 457		
060	98 44	122 56	119 54	138 63	191 87	223 101	157 72	197 90	38-1/2 978	40 1016	18 457	18 457	18 457	18 457		
072	115 52	138 63	139 63	156 71	225 102	251 114	185 84	222 101	38-1/2 978	40 1016	18 457	18 457	18 457	18 457		
090	164 74	187 85	179 81	203 92	221 100	252 114	203 92	231 105	47 1194	47 1194	21 533	21 533	21 533	21 533		

Base Unit - The unit with NO INTERNAL OPTIONS.

Max. Unit - The unit with ALL INTERNAL OPTIONS Installed. (Economizer, Standard Static Power Exhaust Fans, Controls, etc.). Does not include accessories external to unit or high static power exhaust.

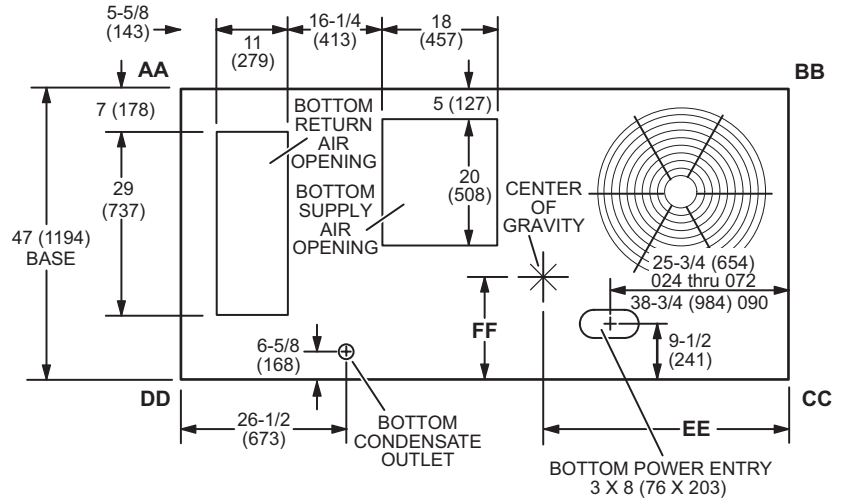

TOP VIEW (Base)

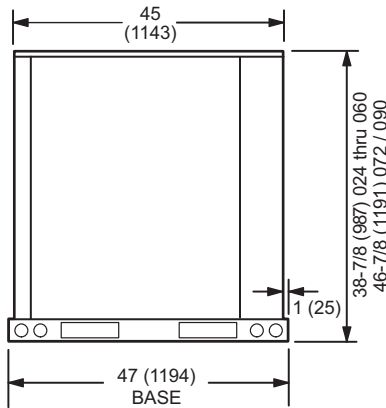

END VIEW

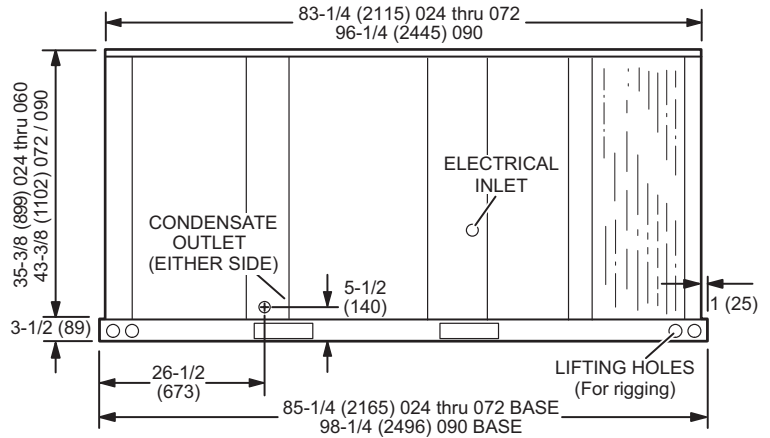

SIDE VIEW

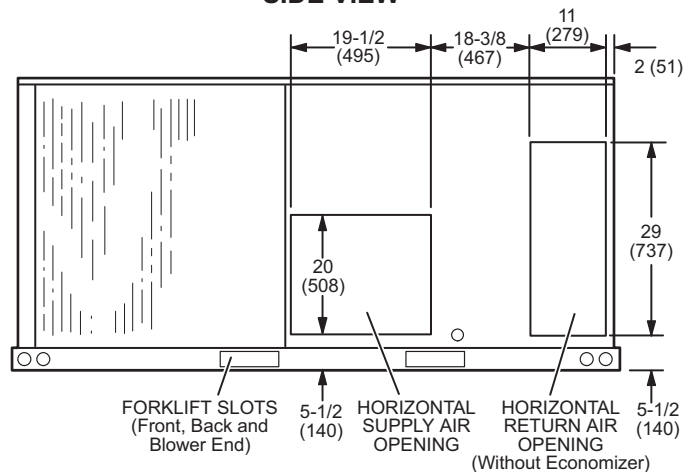

BACK VIEW

ACCESSORY DIMENSIONS - INCHES (MM)

OUTDOOR AIR HOOD DETAIL FOR OPTIONAL ECONOMIZER AND BAROMETRIC RELIEF DAMPERS (Downflow Applications)

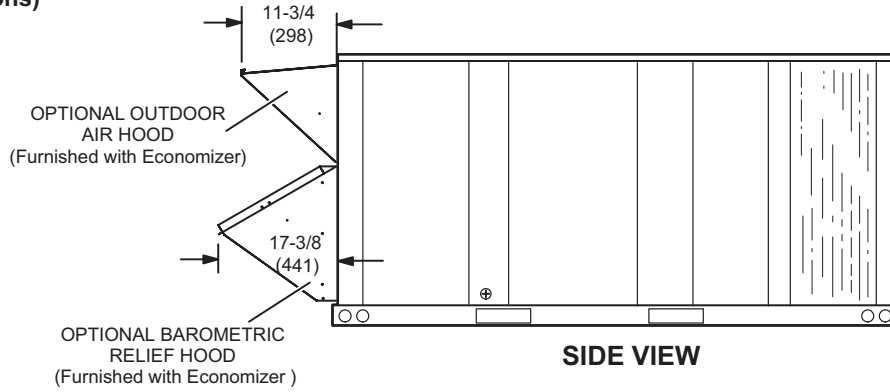

OUTDOOR AIR HOOD FOR ECONOMIZER (Furnished)

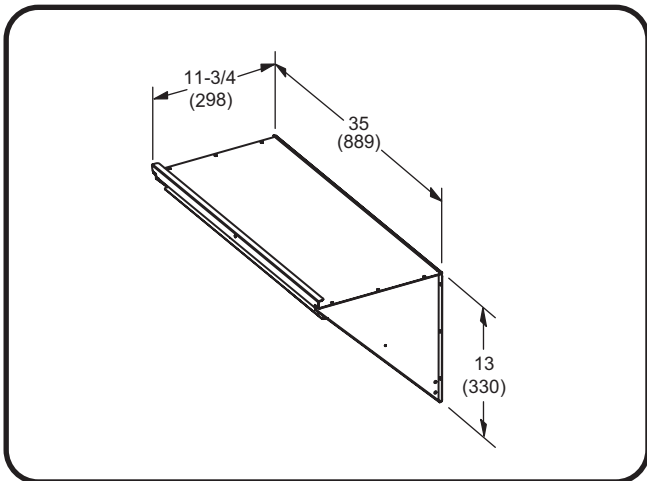

BAROMETRIC RELIEF HOOD FOR ECONOMIZER (Furnished)

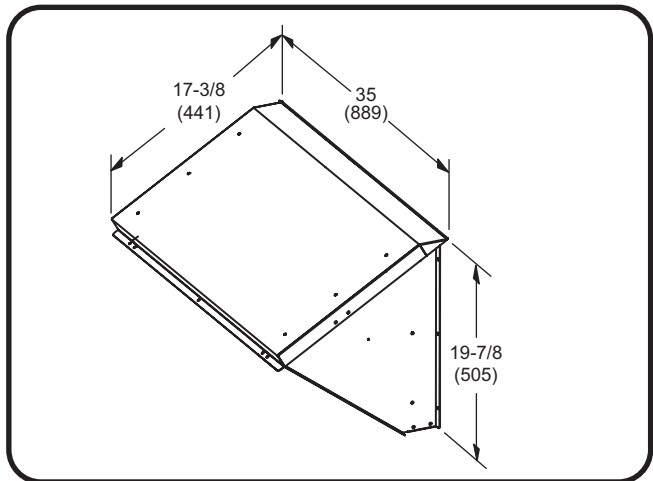

OUTDOOR AIR DAMPER HOOD DETAIL FOR OPTIONAL MANUAL OR MOTORIZED OUTDOOR AIR DAMPERS (Downflow or Horizontal Applications)

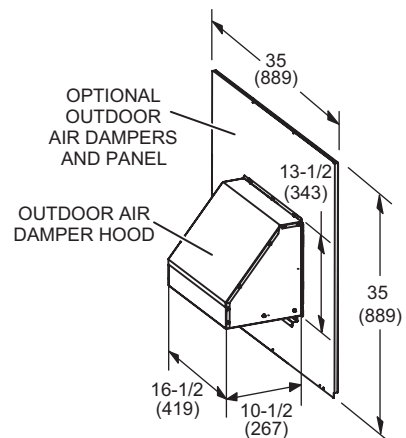
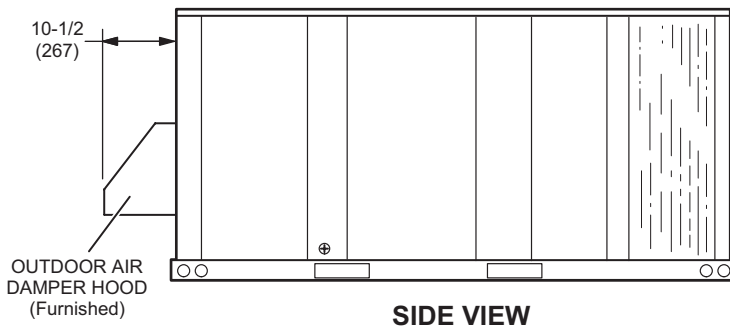

ACCESSORY DIMENSIONS - INCHES (MM)

OUTDOOR AIR HOOD DETAIL WITH OPTIONAL ECONOMIZER AND BAROMETRIC RELIEF DAMPERS (Horizontal Applications)

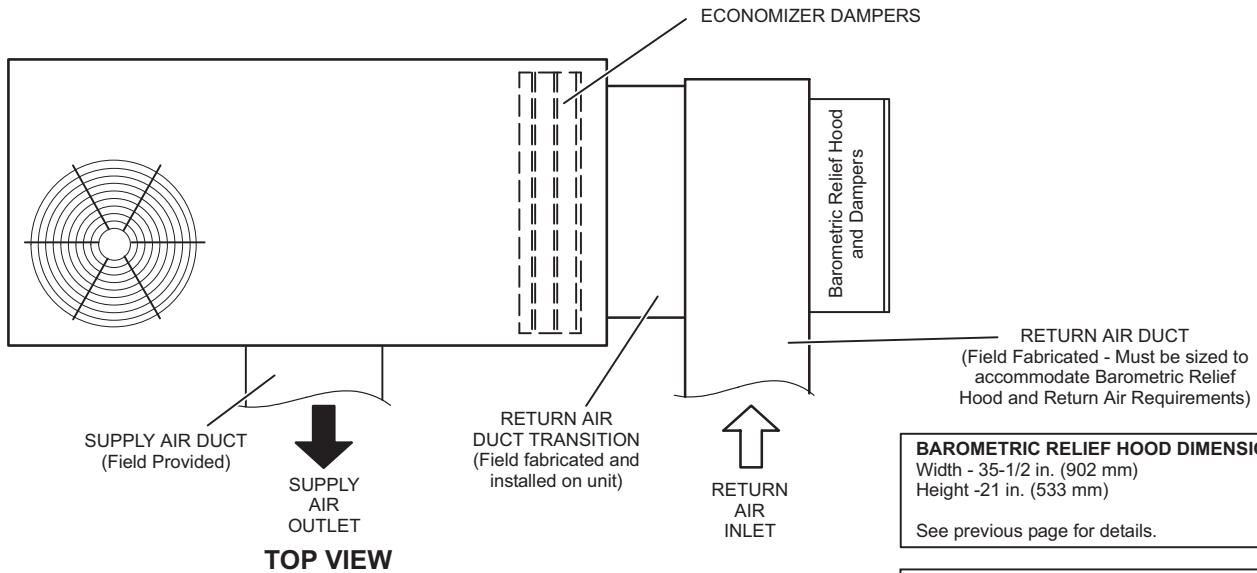

BAROMETRIC RELIEF HOOD DIMENSIONS
 Width - 35-1/2 in. (902 mm)
 Height - 21 in. (533 mm)
 See previous page for details.

NOTE - Horizontal applications with Economizer require Horizontal Economizer Conversion Kit.
 See Options/Accessories table.

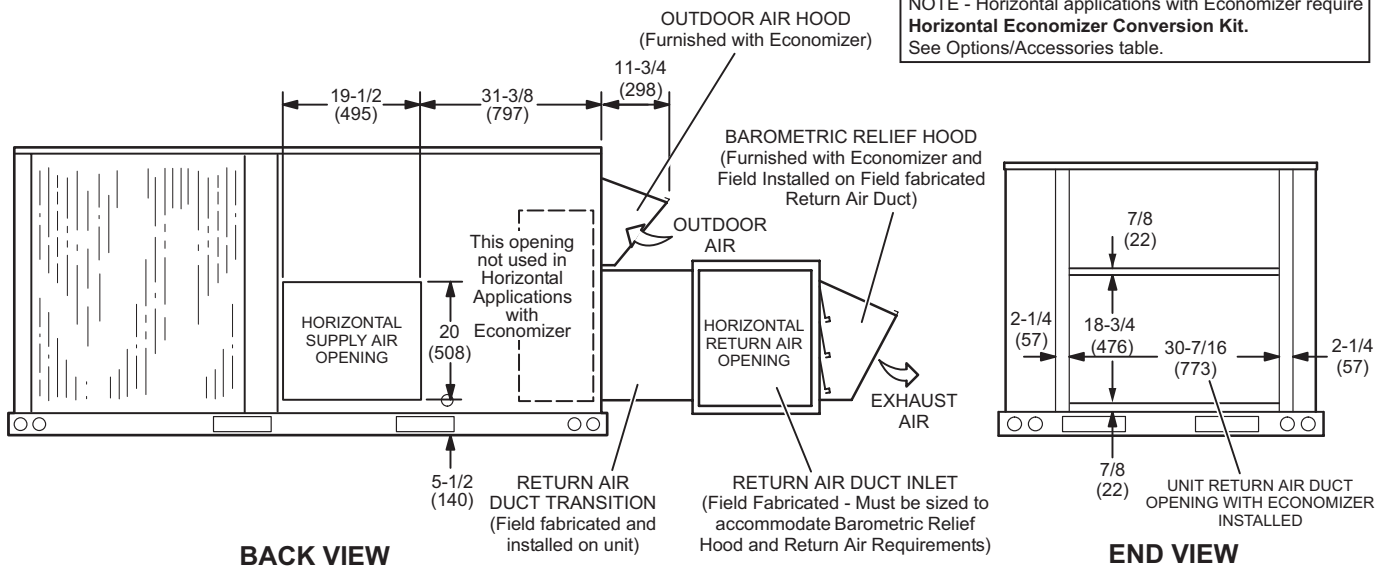

NOTE - Return Air Duct and Transition must be supported.

ACCESSORY DIMENSIONS - INCHES (MM)

HYBRID ROOF CURBS - DOUBLE DUCT OPENING

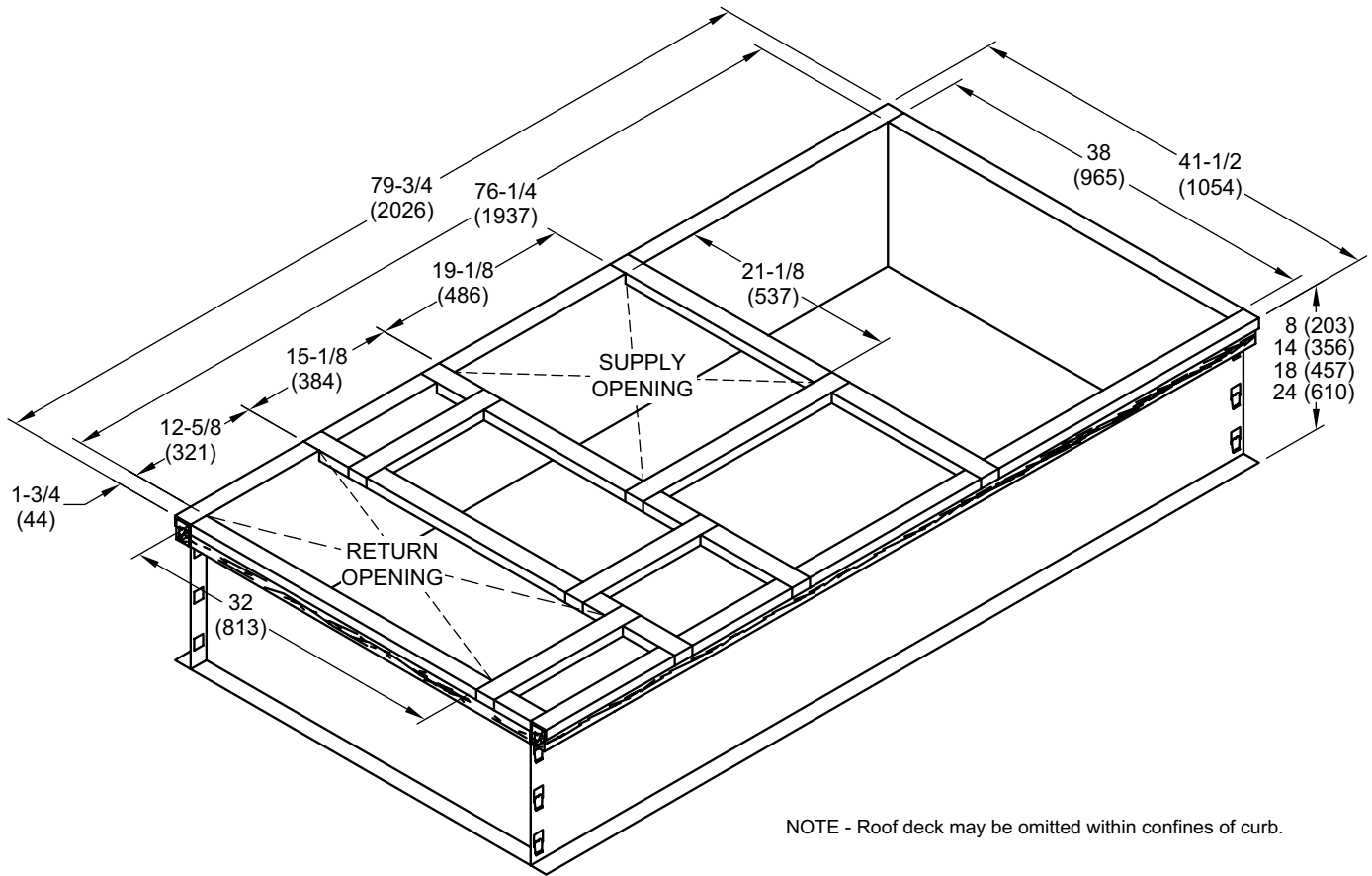

TYPICAL FLASHING DETAIL FOR ROOF CURB

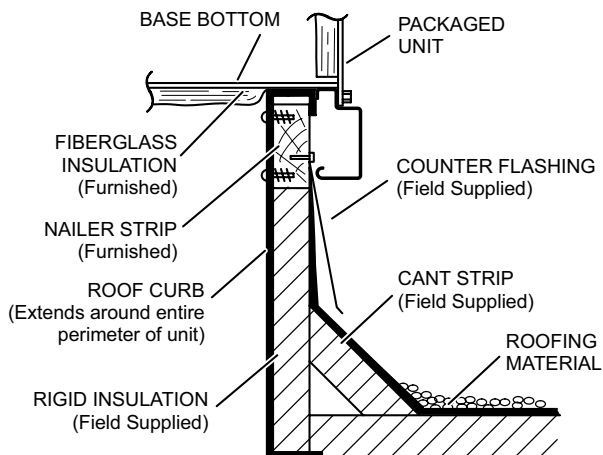

DETAIL ROOF CURB

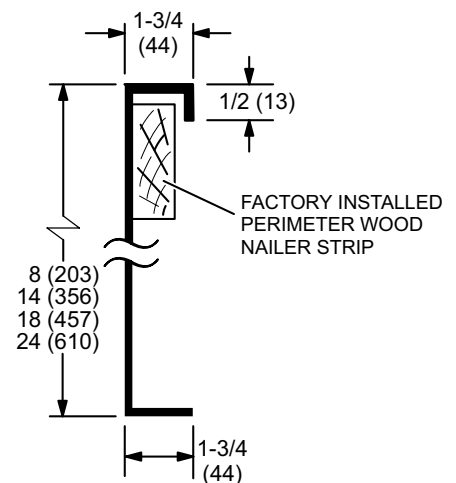

ACCESSORY DIMENSIONS - INCHES (MM)

CLIP CURBS - FULL PERIMETER - DOUBLE DUCT OPENING (090 MODELS ONLY)

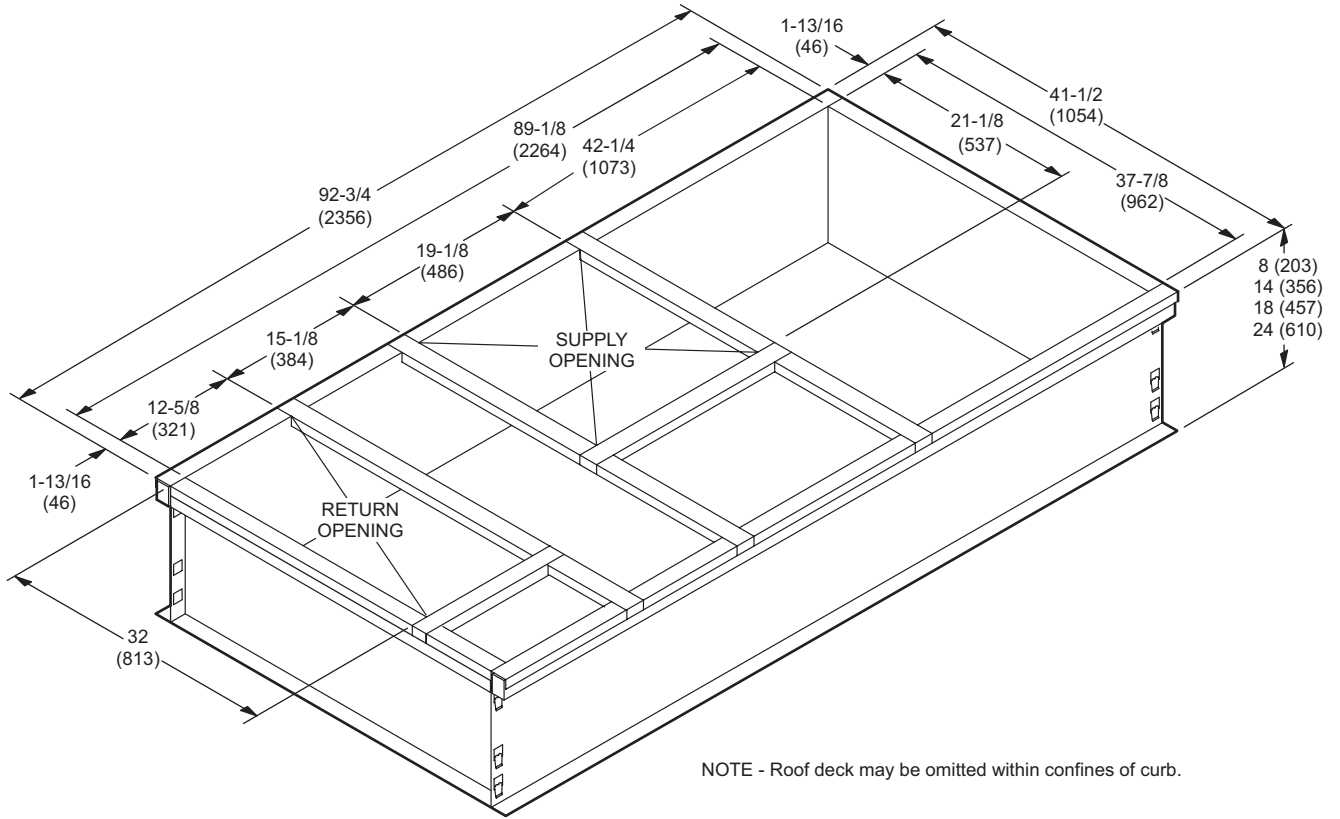

TYPICAL FLASHING DETAIL FOR ROOF CURB

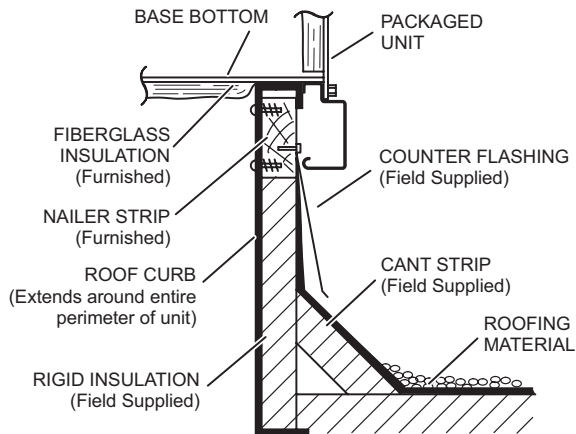

DETAIL ROOF CURB

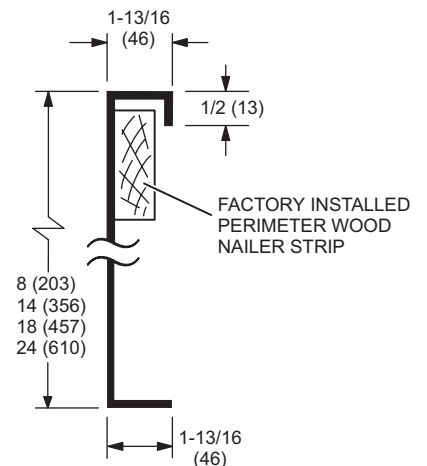

ACCESSORY DIMENSIONS - INCHES (MM)

HINGED ROOF CURBS - FULL PERIMETER - DOUBLE DUCT OPENING (090 MODELS ONLY)

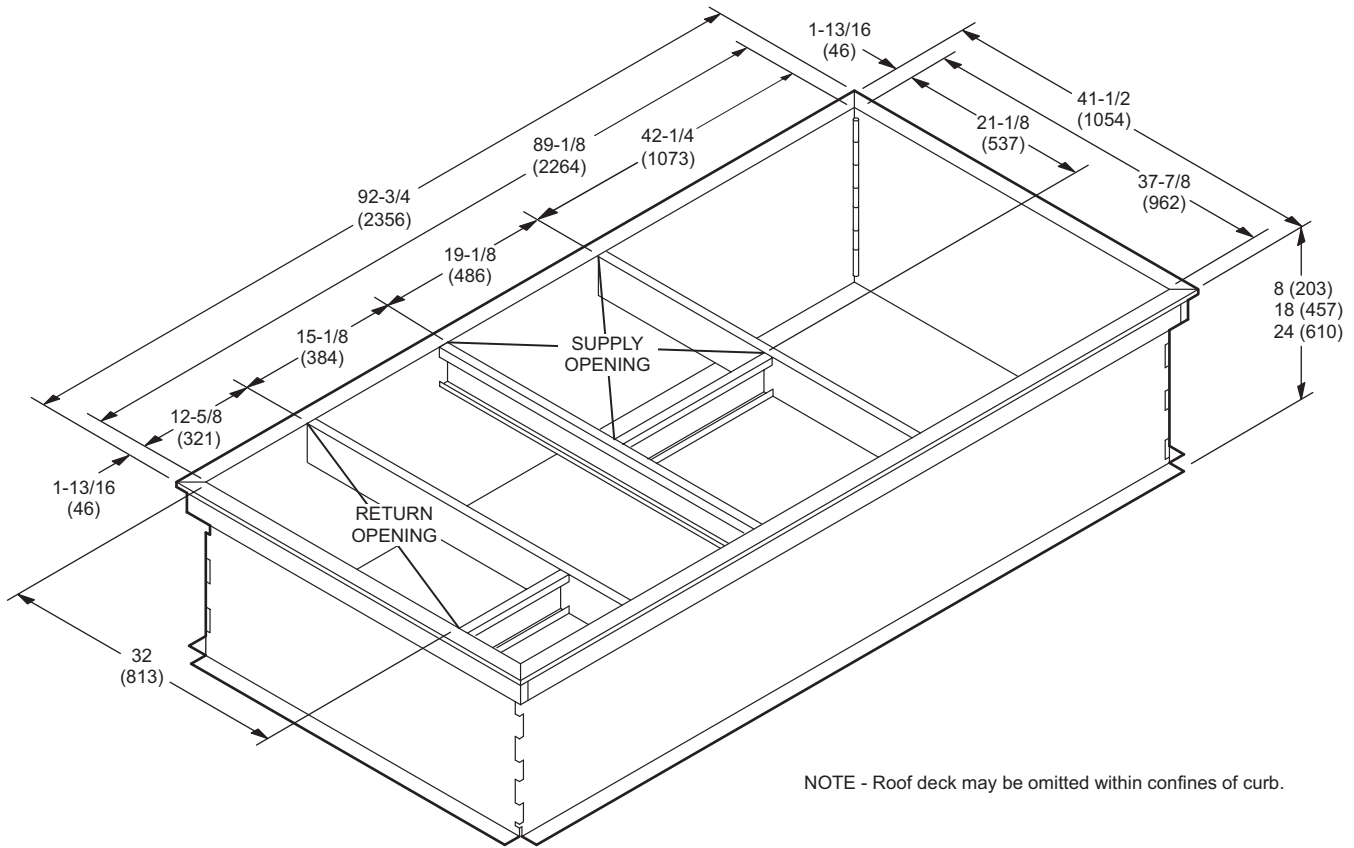

TYPICAL FLASHING DETAIL FOR ROOF CURB

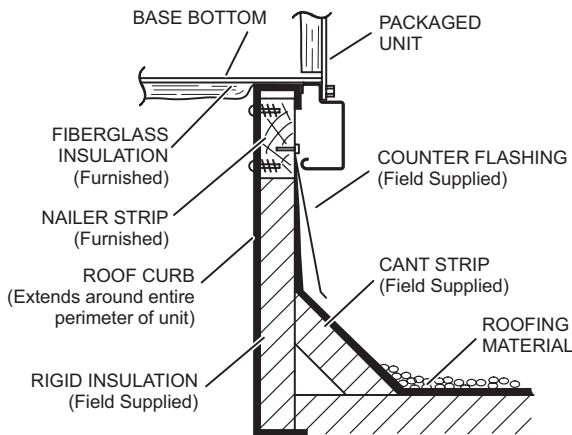

DETAIL ROOF CURB

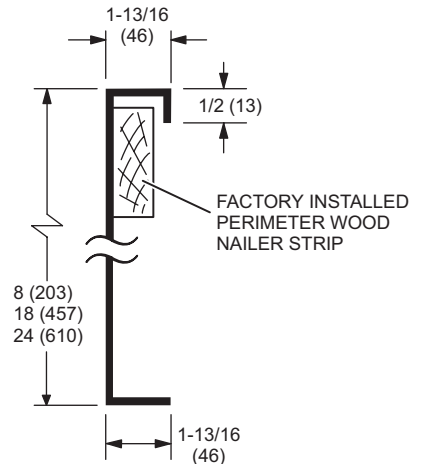

ACCESSORY DIMENSIONS - INCHES (MM)

STANDARD ROOF CURBS - FULL PERIMETER - DOUBLE DUCT OPENING (090 MODELS ONLY)

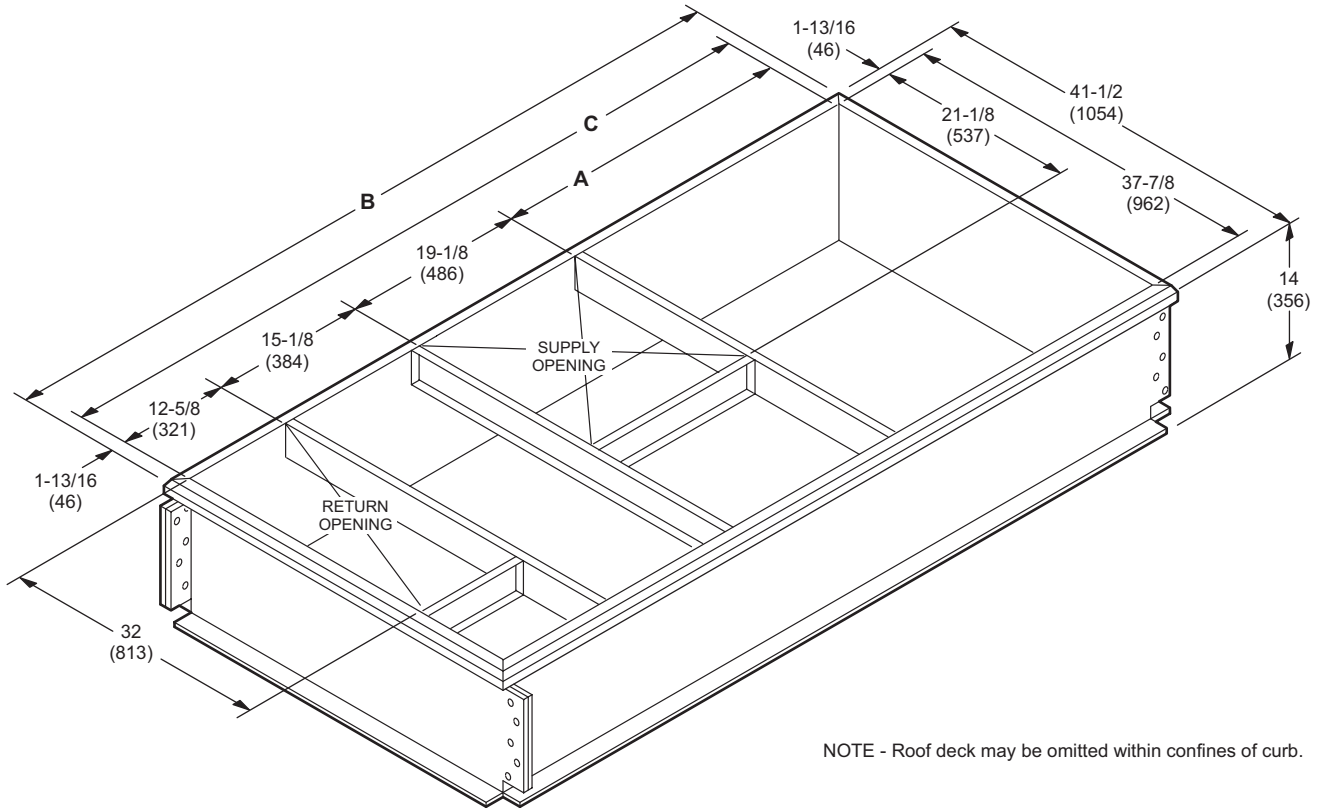

NOTE - Roof deck may be omitted within confines of curb.

TYPICAL FLASHING DETAIL FOR ROOF CURB

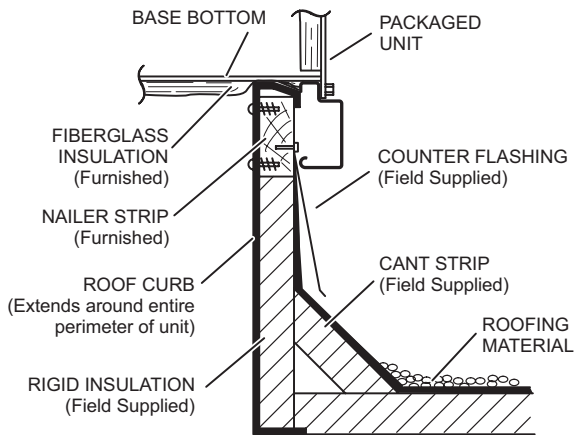

DETAIL ROOF CURB

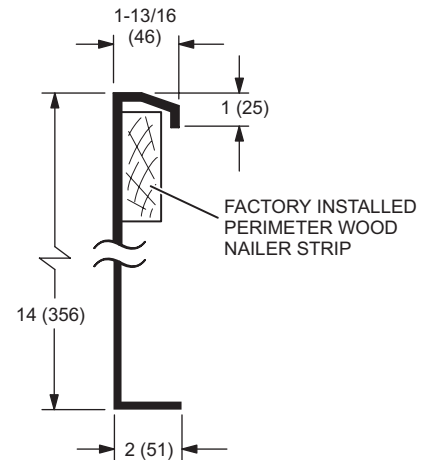

ACCESSORY DIMENSIONS - INCHES (MM)

090 MODELS - SHOWING OVERHANG ON SMALLER 79-3/4 INCH LENGTH ROOF CURBS
(Not Full Perimeter)

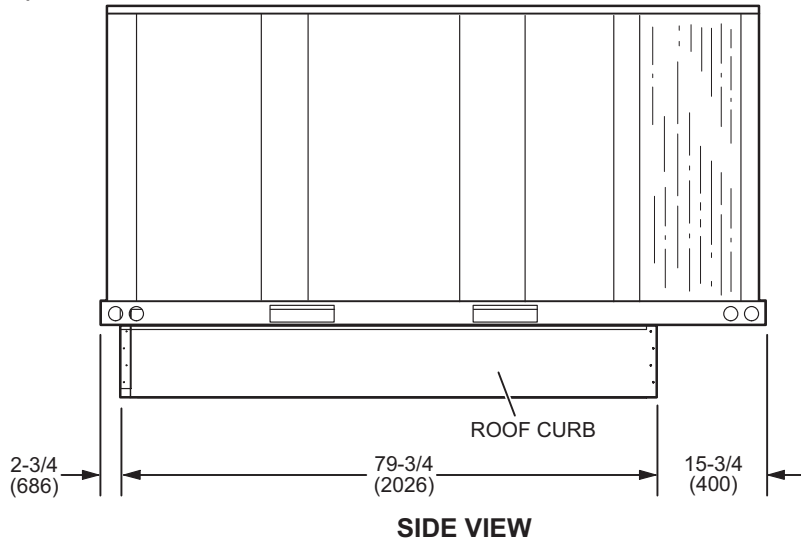

TRANSITIONS

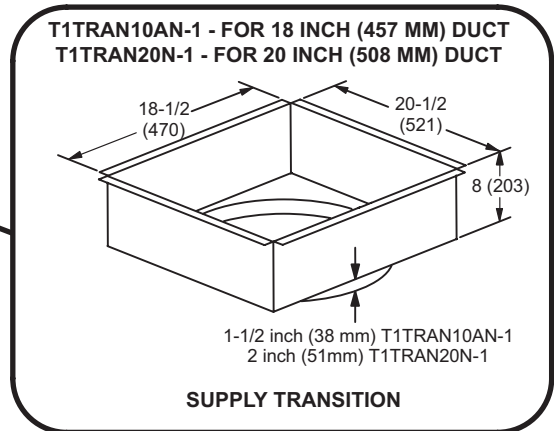
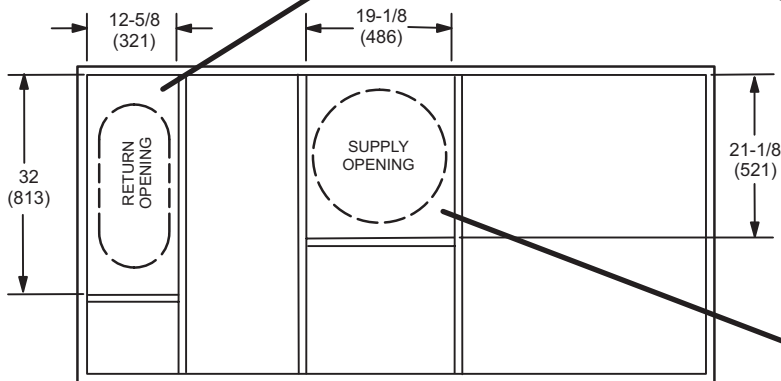
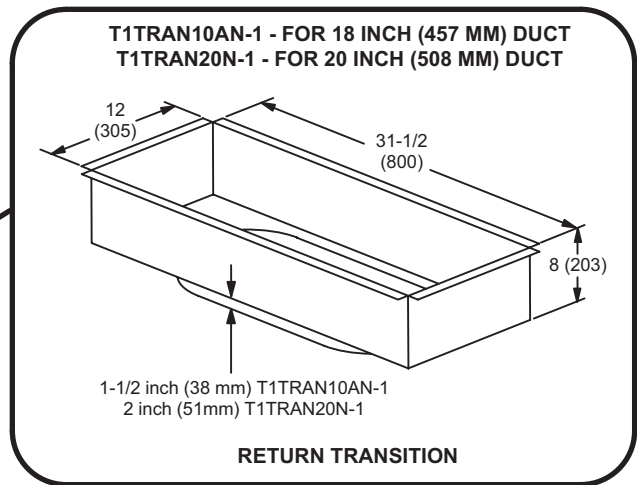

ACCESSORY DIMENSIONS - INCHES (MM)

COMBINATION CEILING SUPPLY AND RETURN DIFFUSERS

STEP-DOWN CEILING DIFFUSER

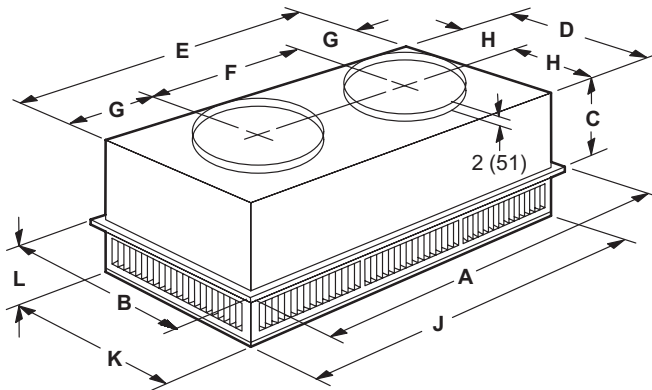

FLUSH CEILING DIFFUSER

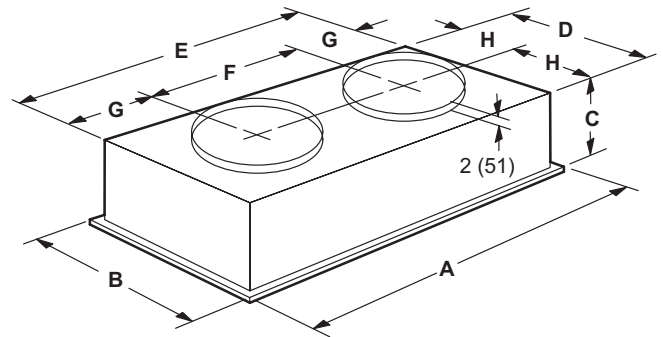

Model Number		RTD9-65	RTD11-95
A	in.	47-5/8	47-5/8
	mm	1159	1159
B	in.	23-5/8	29-5/8
	mm	600	752
C	in.	11-3/8	14-3/8
	mm	289	365
D	in.	21-1/2	27-1/2
	mm	546	699
E	in.	45-1/2	45-1/2
	mm	1156	1158
F	in.	22-1/2	22-1/2
	mm	572	572
G	in.	11-1/2	11-1/2
	mm	292	292
H	in.	10-3/4	13-3/4
	mm	273	349
J	in.	45-1/2	45-1/2
	mm	1156	1156
K	in.	21-1/2	27-1/2
	mm	546	699
L	in.	7-1/8	8-1/8
	mm	181	206
Duct Size	in.	18 round	20 round
	mm	457 round	508 round

Model Number		FD9-65	FD11-95
A	in.	47-5/8	47-5/8
	mm	1159	1159
B	in.	23-5/8	29-5/8
	mm	600	752
C	in.	13-1/2	16-5/8
	mm	343	422
D	in.	21	27
	mm	533	686
E	in.	45	45
	mm	1143	1143
F	in.	22-1/2	22-1/2
	mm	572	572
G	in.	11-1/4	11-1/4
	mm	286	286
H	in.	10-1/2	13-1/2
	mm	267	343
Duct Size	in.	18 round	20 round
	mm	457 round	508 round

REVISIONS

Section	Description
Options/Accessories	Removed larger accessories (Economizers, Power Exhaust, Outdoor Air Dampers, Barometric Relief Dampers) for 072/090 models. All sizes now use the same accessories.



Visit us at www.lennox.com

For the latest technical information, www.lennoxcommercial.com

Contact us at 1-800-4-LENNOX

NOTE - Due to Lennox' ongoing commitment to quality, Specifications, Ratings and Dimensions subject to change without notice and without incurring liability. Improper installation, adjustment, alteration, service or maintenance can cause property damage or personal injury. Installation and service must be performed by a qualified installer and servicing agency.

©2014 Lennox Industries, Inc.