



United Technologies
turn to the experts

40RUM Packaged Air Handler Units – 50Hz



Quality Assurance
Certificate Reg. No:
04 100 950420



Subject to change without notice

Manufacturer's Name: Saudi Airconditioning Manufacturing Co. Ltd.

Country of origin : Jeddah, Saudi Arabia

Nearest port of embarkation: Jeddah Islamic port

Product classification: Commercial and Residential

Installation Operation Maintenance Manual

40RUM Packaged Air Handler Units – 50Hz

Nominal Cooling Capacity 6.0 – 15.0 Tons

HFC R-410A Refrigerant

The 40RUM Series air-handling units are the best choice for packaged air handlers. Model 40RUM units have direct-expansion coils. All models offer excellent fan performance, a unique combination of indoor air quality features, easy installation, and affordable prices. Their versatility and state-of-the-art features will provide economical performance now and in the future.

Contact your local Carrier representative for additional reference materials.

Table of Contents

Safety Considerations	2
Unit Physical Data	4
Base Dimensional Drawing	5
Pre-Installation / Installation	7
Start-Up / Service	14
Electrical Data Table / Electrical Heater Data Table	18
Typical Wiring Schematic	20
Fan Performance Data / Performance Data	21
R-410A Refrigerant Quick Reference Guide	24
Troubleshooting Guide	25
Mandatory Startup Checklist and Record	26

SAFETY CONSIDERATIONS

General

Improper installation, adjustment, alteration, service, maintenance or use can cause explosion, fire, electrical shock or other conditions which may cause personal injury or property damage. Consult a qualified installer; service agency must use factory-authorized kits or accessories when modifying this product. Refer to the individual instructions packaged with the kits or accessories when installing.

Follow all the safety codes. Wear safety glasses and work gloves. Use quenching cloths for brazing operations and have a fire extinguisher available. Read these instructions thoroughly and follow all warnings or cautions attached to the unit. Consult local building codes for special requirements. In absence of local codes, it is recommended that the USA standard ANSI/NFPA 70, National Electrical Code (NEC), be followed.

It is important to recognize safety information. This is the safety-alert symbol . When you see this symbol on the unit and in instructions or manuals, be alert to the potential for personal injury.

Understand the signal words DANGER, WARNING, CAUTION, and NOTE. These words are used with the safety-alert symbol. DANGER identifies the most serious hazards which **will** result in severe personal injury or death. WARNING signifies hazards which **could** result in personal injury or death. CAUTION is used to identify unsafe practices, which **may** result in minor personal injury or product and property damage. NOTE is used to highlight suggestions which **will** result in enhanced installation, reliability, or operation.

Installation Safety Considerations

After the unit has been received and when it is ready to be installed or reinstalled, it must be inspected for damage. If damage is detected upon receipt, immediately file a claim with the shipping company or repair.

This machine must be installed in a location that is not accessible to the public and protected against access by non-authorized people. This machine must not be installed in an explosive atmosphere.

Do not remove the skid or the packaging until the unit is in its final position. The units can also be lifted with slings, using only the designated lifting points marked on the unit (labels on the chassis and a label with all unit handling instructions are attached to the unit). Use slings with the correct capacity, and always follow the lifting instructions on the certified drawings supplied for the unit.

Safety is only guaranteed, if these instructions are carefully followed. If this is not the case, there is a risk of material deterioration and injuries to personnel. These units are not designed to be lifted from above.

Warranty

Warranty is based on the general terms and conditions of the manufacturer. Any modifications to the design and/or installation made without discussion with Carrier and without advance written agreement will result in the loss of the right to any warranty claims and any claim for injury to personnel as a result of these modifications.



WARNING

ELECTRIC SHOCK HAZARD

Failure to follow this warning could cause personal injury or death.

Before performing service or maintenance operations on unit, always turn off main power switch to unit and install lockout tag. Unit may have more than one power switch.



CAUTION

CUT HAZARD

Failure to follow this warning could cause personal injury.

Sheet metal parts may have sharp edges or burrs. Use care and wear appropriate protective clothing, safety glasses and gloves when handling parts and servicing air conditioning equipment



WARNING

UNIT OPERATION AND SAFETY HAZARD

Failure to follow this warning could cause personal injury, death and /or equipment damage.

Puron® (R-410A) refrigerant systems operate at higher pressures than standard R-22 systems. Do not use R-22 service equipment or components on Puron® refrigerant equipment.



WARNING

PERSONAL SAFETY AND ENVIRONMENTAL HAZARD

Failure to follow this warning could cause personal injury or death damage.

Relieve pressure and recover all refrigerant before system repair or final unit disposal. Wear safety glasses and gloves when handling refrigerants. Keep torches and other ignition sources away from refrigerants and oils.

UNIT PHYSICAL DATA (ENGLISH UNITS)

Unit 40RUM	07	08	12	14	16
Nominal Capacity	6.0	7.5	10.0	12.5	15.0
Operating Weight (lb)					
Base Unit with TXV (4 Rows)	399	404	425	695	713
Plenum	175		225		
Fans					
Qty / Diameter (in)	1 / 15			2 / 15	
Nominal Airflow (cfm)	2400	3000	4000	5000	6000
Airflow Range (cfm)	1800-3000	2250-3750	3000-5000	3750-6250	4500-7500
Nominal Motor HP (Std. Motor)	2.4		2.9		
Motor Speed (rpm)	1425				
Refrigerant	Puron® (R-410A)				
Operating Charge (lb)	12.8	13.7	11.66 / 11.66	15.4 / 16.3	20.9 / 19.2
Initial Charge (lb)	7.7	8.2	7.0 / 7.0	9.0 / 9.7	12.5 / 11.5
Piping Connections					
Suction line - Qty. / Size (in)	1 / 7/8		2 / 7/8		
Liquid line - Qty. / Size (in)	1 / 3/8	1 / 1/2	2 / 3/8		2 / 1/2
Filters	Washable - Aluminum				
Qty. / Size (in)	4 / 16x24x1			8 / 16x24x1	
Direct Expansion Coils	Enhanced Copper Tubes, Aluminum Double Wavy Fins				
Face Area (sq ft)	6.67	8.33	10.01	13.25	17.67
Max Working Pressure (psig)	650				
Fins/Inch	15				
No. of Rows	4				

UNIT PHYSICAL DATA (SI UNITS)

Unit 40RUM	07	08	12	14	16
Nominal Capacity	6.0	7.5	10.0	12.5	15.0
Operating Weight (kg)					
Base Unit with TXV (4 Rows)	181	183	193	315	323
Plenum	80		102		
Fans					
Qty / Diameter (mm)	1 / 381			2 / 381	
Nominal Airflow (L/s)	1133	1604	1888	2360	2831
Airflow Range (L/s)	850-1416	1203-2006	1416-2360	1770-2949	2124-3539
Nominal Motor kW (Std. Motor)	1.79		2.16		
Motor Speed (r/s)	23.8				
Refrigerant	Puron (R-410A)				
Operating Charge (kg)	5.8	6.2	5.29 / 5.29	6.99 / 7.39	9.5 / 8.75
Initial Charge (kg)	3.5	3.7	3.2 / 3.2	4.1 / 4.4	5.7 / 5.25
Piping Connections					
Suction line - Qty. / Size (mm)	1 / 22		2 / 22		
Liquid line - Qty. / Size (mm)	1 / 9.5	1 / 12.7	2 / 9.5		2 / 12.7
Filters	Washable - Aluminum				
Qty. / Size (mm)	4 / 406x610x25.4			8 / 406x610x25.4	
Direct Expansion Coil	Enhanced Copper Tubes, Aluminum Double Wavy Fins				
Face Area (sq m)	0.62	0.77	0.93	1.23	1.64
Max Working Pressure (kPag)	4481				
Fins/meter	591				
No. of Rows	4				

BASE UNIT DIMENSIONS – 40RUM Series Size 07-12

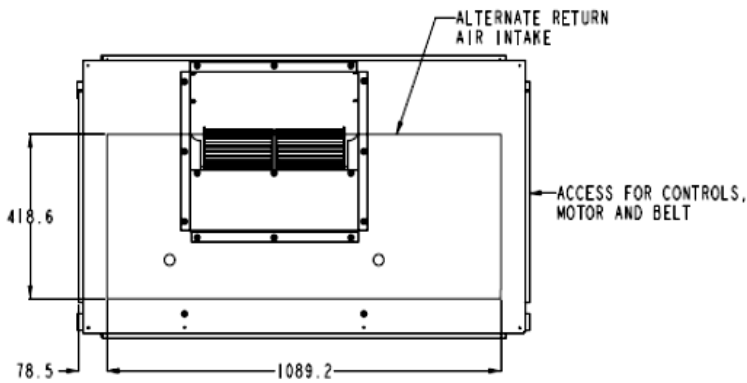

Top

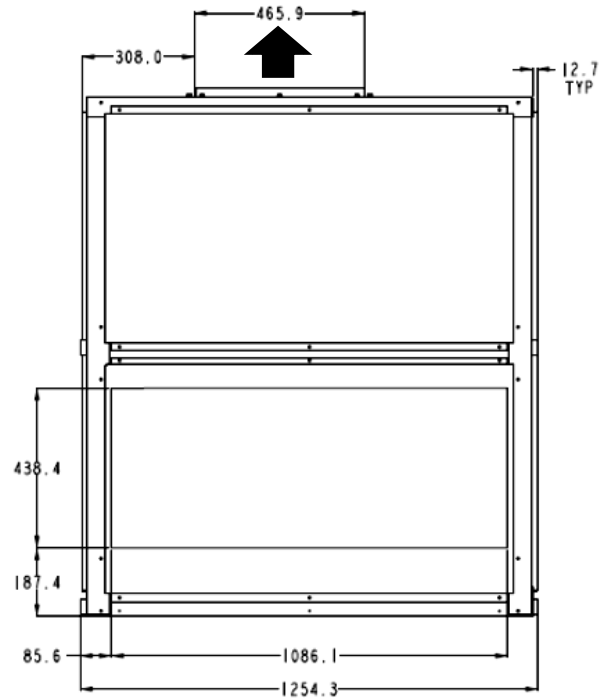

Front

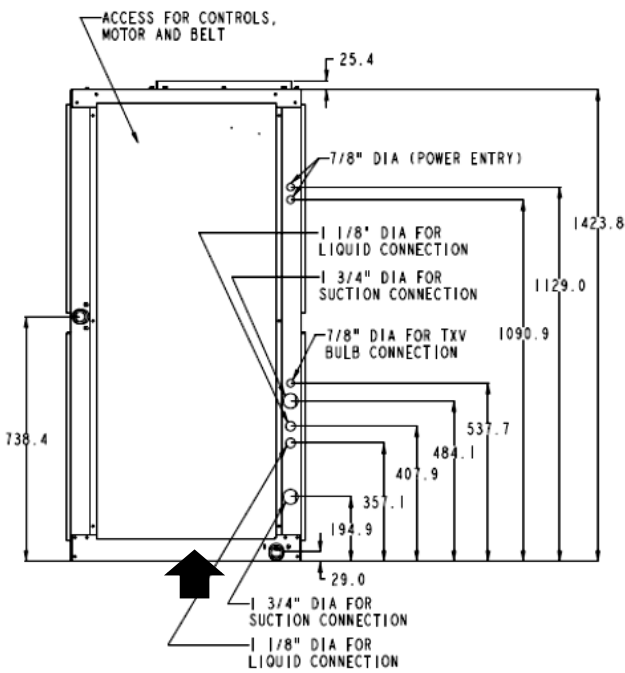

Right Side

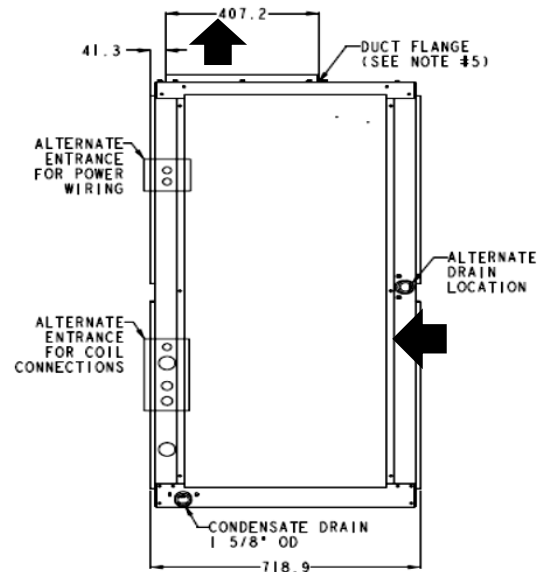

Left Side

Notes:

1. Dimensions are in millimeter (mm).
2. Direction of airflow.
3. Recommended clearance:
 - Rear: 3.0 in (76.2mm)
 - Front: 2.0ft 6.0in (762mm)
 - Right Side: 2.0ft 6.0in (762mm)
 - Left Side: 2.0ft 6.0in (762mm)
4. Liquid piping not supplied by Carrier.
5. Duct flange is factory installed.

BASE UNIT DIMENSIONS – 40RUM Series Size 14 - 16

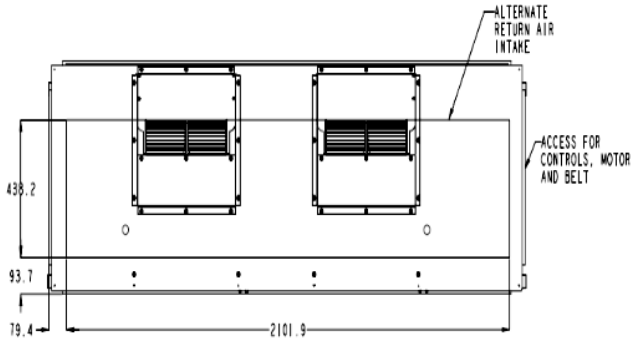

Top

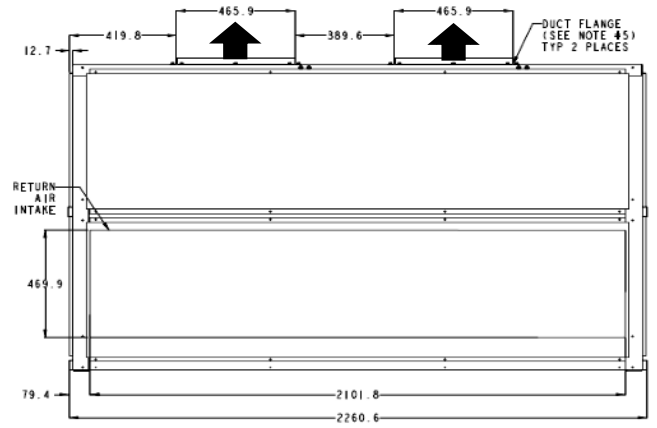

Front

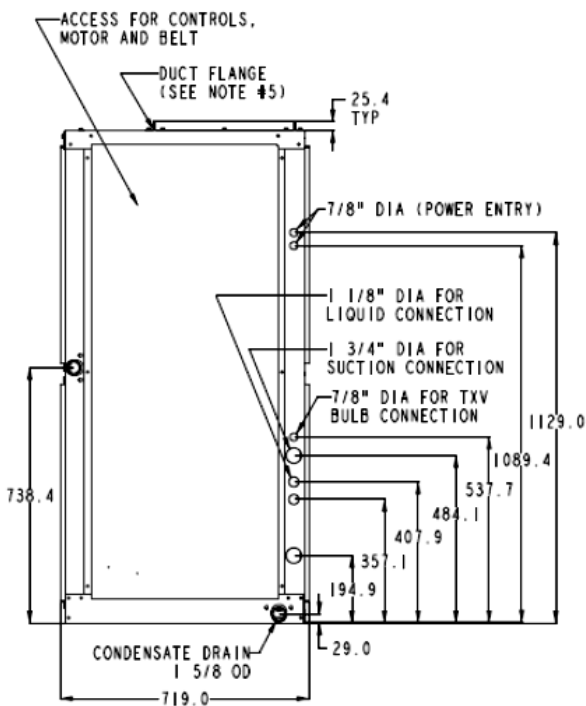

Right Side

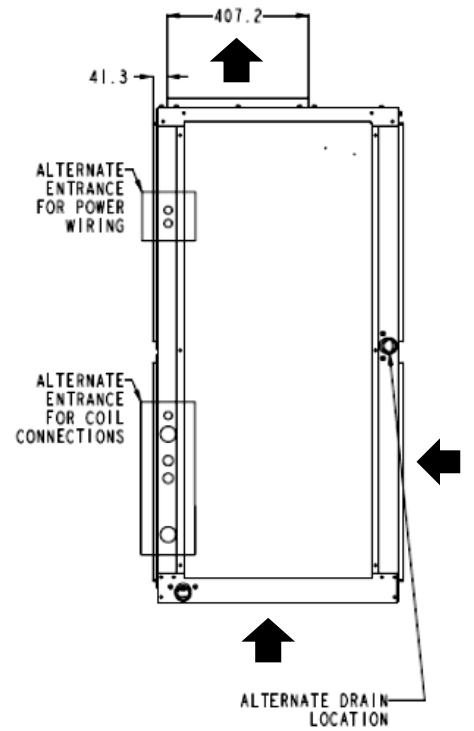

Left Side

Notes:

1. Dimensions are in millimeter (mm).
2. ➡ Direction of airflow.
3. Recommended clearance:
 - Rear: 3.0 in (76.2mm)
 - Front: 2.0ft 6.0in (762mm)
 - Right Side: 2.0ft 6.0in (762mm)
 - Left Side: 2.0ft 6.0in (762mm)
4. Liquid piping not supplied by Carrier.
5. Duct flange is factory installed.

PRE-INSTALLATION

Pre-Installation

1. The power supply (v, ph, and Hz) must correspond to that specified on unit rating plate.
2. The electrical supply provided by the utility must be sufficient to handle load imposed by this unit.
3. Refer to Installation, General section for locations of electrical inlets, condensate drain, duct connections, and required clearances before setting unit in place.
4. This installation must conform with local building codes and with the NEC (National Electrical Code) provincial and local plumbing or wastewater codes and other applicable local codes.

Moving and Storage - To transfer unit from truck to storage site, use a fork truck. Do not stack units more than 2 high during storage. If unit is to be stored for more than 2 weeks before installation, choose a level, dry storage site free from vibration. Do not remove plastic wrap or skid from unit until final installation.

Rigging - All 40RUM Series units can be rigged by using the shipping skid. Units are shipped fully assembled. Do not remove shipping skids or protective covering until unit is ready for final placement; damage to bottom panels can result. Use slings and spreader bars as applicable to lift unit.

INSTALLATION

General - Allow the following clearances for service access and airflow:

- Rear: 3 ft (914 mm) [2 1/2 ft (762 mm) with electric heat accessory]
- Front: 2 1/2 ft (762 mm)
- Right Side: 3 1/2 ft (1067 mm)
- Left Side: 2 1/2 ft (762 mm)

Be sure floor, wall, or ceiling can support unit weight, refer Dimensional Drawing for dimensions.

Uncrating - Move unit as near as possible to final location before removing shipping skid.

Remove metal banding, top skid, and plastic wrap. Examine unit for shipping damage. If shipping damage is evident, file claim with transportation agency. Remove base skid just prior to actual installation. Check nameplate information against available power supply and model number description.

NOTE: Be sure to remove the styrofoam shipping pad from the thermostatic expansion valve (TXV). Verify that it has been removed

Accessories - Refer to instructions shipped with each accessory for specific information.

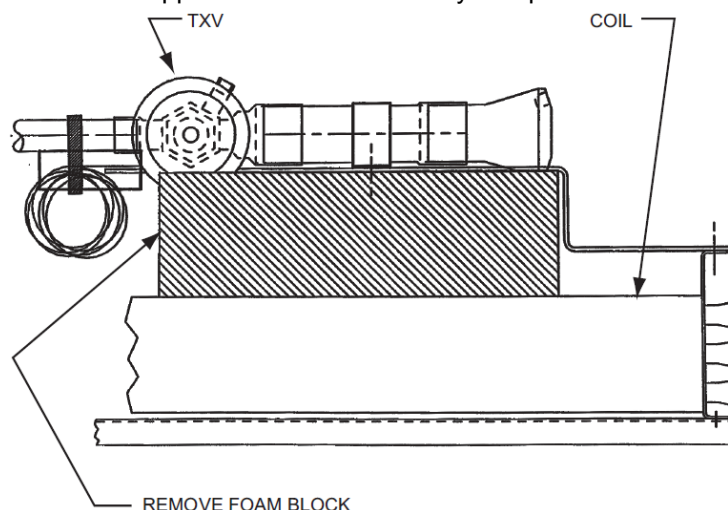

Foam Block Location

Unit Positioning - The unit can be mounted on the floor for vertical application with return air entering the face of the unit and supply air discharging vertically through the top of the unit. The unit can also be applied in a horizontal arrangement with return air entering horizontally and the supply air discharging horizontally. When applying the unit in a horizontal arrangement, ensure the condensate drain pan is located at the bottom center of the unit for adequate condensate disposal. See Typical Unit Positioning for condensate connections for each unit position.

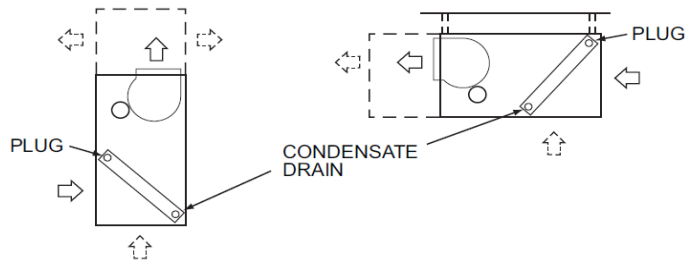

LEGEND

- Accessory Line
- ↔ Alternate Air Intake and Discharge
- ➡ Air Intake and Discharge

Typical Unit Positioning

Note: Maintain recommended clearances

IMPORTANT: Do NOT attempt to install unit with return air entering top panel of unit. Condensate will not drain from unit. Typical positioning and alternate return air locations are shown in Typical Unit Positioning. Alternate return air locations can be used by moving the unit panel from the alternate return air location to the standard return air location. Refer to overhead suspension accessory drawing for Preferred Suspension Technique. The unit needs support underneath to prevent sagging.

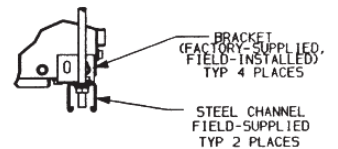
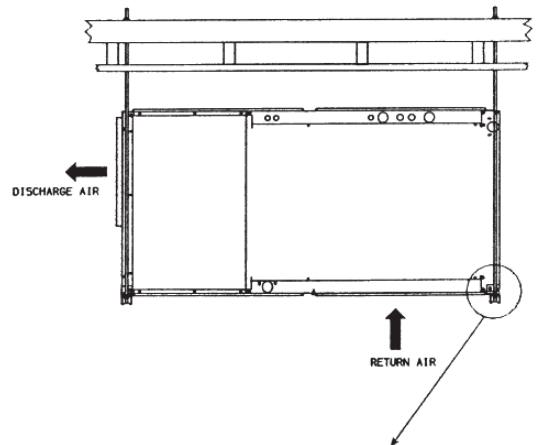
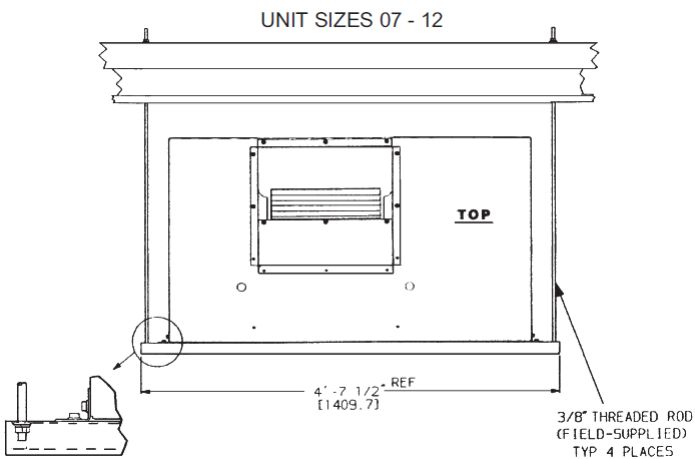

UNIT SIZES 14 - 16

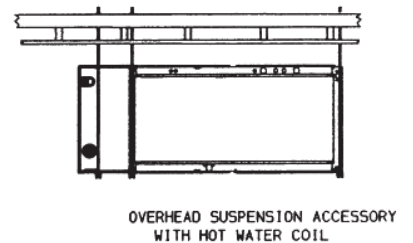
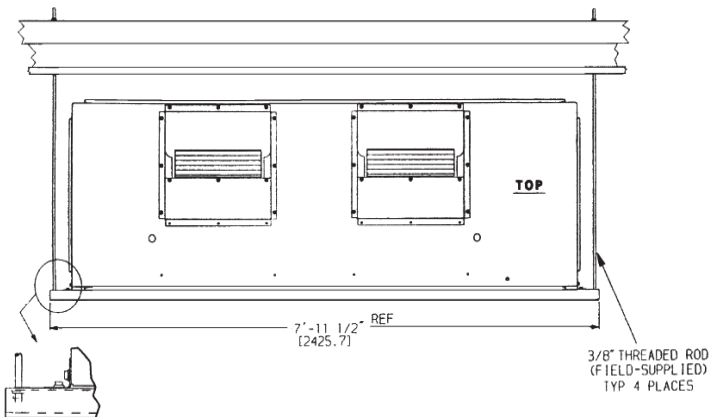

Note: Dimensions in [] are millimeters
Preferred Suspension Technique

Unit Isolation - Where extremely quiet operation is essential, install isolators between floor and base of unit, or between ceiling and top section of unit. Be sure that unit is level and adequately supported. Use channels at front and sides of unit for reference points when leveling.

Refrigerant Piping Access – The 40RUM Series units come with standard knockouts for refrigerant. These knockouts are located on both sides of the unit for installation flexibility. The standard knockouts provide sufficient access to the unit’s coils for all 40RUM units. Recommended access hole use is also listed for all units. Unit Dimensional Drawing shows the access holes on the control-box side of the unit; this is the side of the unit with the coil headers, so it is used most often for piping access.

The 40RUM direct-expansion units have internal factory--installed thermostatic expansion valves (TXVs), distributors, and nozzles for use with R-410A. Knockouts are provided in the unit corner posts for 40RUM refrigerant piping. See Unit Dimensional Drawing, which also lists recommended knockouts and access holes to use for each 40RUM unit size. Recommended fittings are also listed.

The sensor bulb capillary tubes must be routed from the TXVs inside the unit through one of the piping access holes. Clamp the TXV sensor bulb on a vertical portion of the suction line, outside the unit. See Fig. 9.

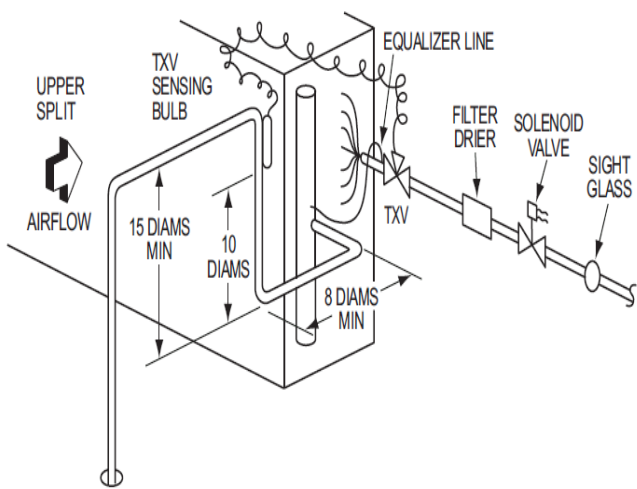

Single Circuit Coil Piping Configuration RUM 07, 08
For single compressor condensing units.

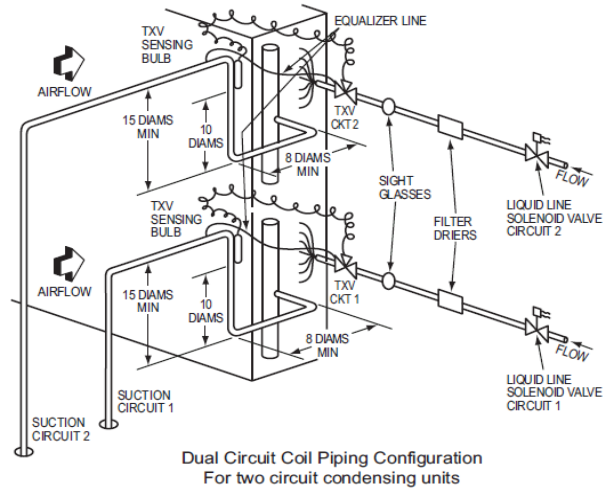

Dual Circuit Coil Piping Configuration RUM 10 - 16
For single compressor condensing units.

Face-Split Coil Suction and Liquid Line Piping (Typical)

LEGEND:

TXV – Thermostatic Expansion Valve

NOTE: Component location arrangement shown for field installation of sight glasses, solenoid valves, filter driers, and TXV sensing bulbs. The TXVs and equalizer lines are factory installed.

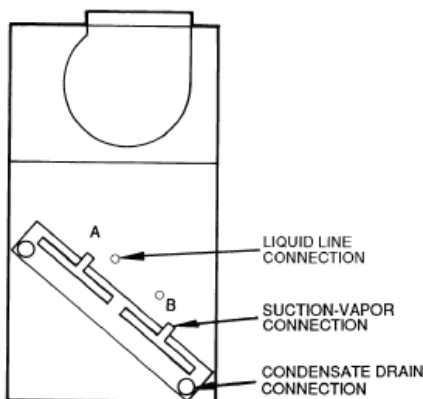

FIRST ON/LAST OFF = B
VERTICAL INSTALLATION

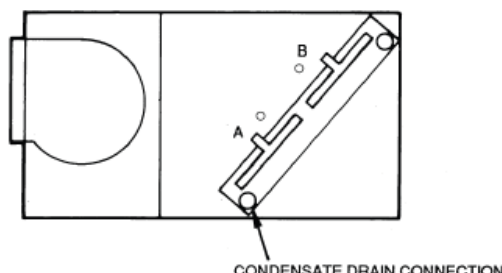

FIRST ON/LAST OFF = A
HORIZONTAL INSTALLATION

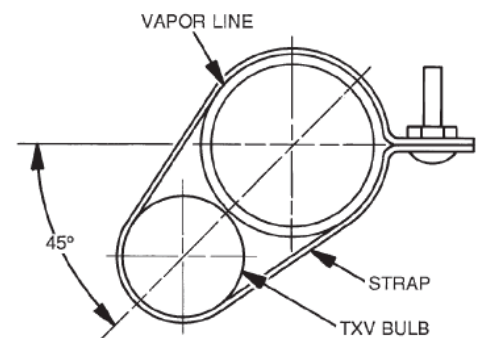

LEGEND
TXV – Thermostatic Expansion Valve
NOTE: The 8 o'clock position is shown above.

Typical Evaporator Coil Connections (40RUM)

TXV Sensing Bulb Location

Fitting Requirements

Unit	Access Hole No ▲	Connection Type	Circuit	Fittings Required (in.) ▼
40RUM*07	1	Suction	-	1 - 1/8 Street Elbow 1 - 1/8 Nipple, 10 - 5/8 L 1 - 1/8 Long Radius Elbow
	3	Liquid	-	5/8 Street Elbow 5/8 Nipple, 8 - 5/8 L 5/8 Long Radius Elbow
40RUM*08	1	Suction	-	1 - 1/8 Street Elbow 1 - 1/8 Nipple, 8 - 5/8 L 1 - 1/8 Long Radius Elbow
	3	Liquid	-	5/8 Street Elbow 5/8 Nipple, 8 - 5/8 L 5/8 Long Radius Elbow
40RUM*12	1	Suction	Lower	(2) 1 - 1/8 Street Elbow
	2	Liquid	Lower	5/8 Street Elbow 5/8 Nipple, 8 - 1/2 L 5/8 Long Radius Elbow
	3	Liquid	Upper	5/8 Street Elbow 5/8 Nipple, 13 - 1/2 L 5/8 Long Radius Elbow
	4	Suction	Upper	1 - 1/8 Nipple, 5 - 3/4 L 1 - 1/8 Long Radius Elbow 1 - 1/8 Nipple, 12 L 1 - 1/8 Long Radius Elbow
40RUM*14	1	Suction	Lower	1 - 1/8 Street Elbow 1 - 1/8 Nipple, 75/8 L 1 - 1/8 Long Radius Elbow
	2	Liquid	Lower	5/8 Street Elbow 5/8 Nipple, 1 - 7/16 L 5/8 Long Radius Elbow
	3	Liquid	Upper	5/8 Street Elbow 5/8 Nipple, 11 - 1/2 L 5/8 Long Radius Elbow
	4	Suction	Upper	1 - 1/8 Nipple, 5 - 5/8 L 1 - 1/8 Long Radius Elbow 1 - 1/8 Nipple, 13 L 1 - 1/8 Long Radius Elbow
40RUM*16	1	Suction	Lower	1 - 1/8 Street Elbow 1 - 1/8 Nipple, 72 - 3/4 L 1 - 1/8 Long Radius Elbow
	2	Liquid	Lower	5/8 Street Elbow 5/8 Nipple, 1 - 3/8 L 5/8 Long Radius Elbow
	3	Liquid	Upper	5/8 Street Elbow 5/8 Nipple, 11 - 1/2 L 5/8 Long Radius Elbow
	4	Suction	Upper	1 - 1/8 Nipple, 5 - 5/8 L 1 - 1/8 Long Radius Elbow 1 - 1/8 Nipple, 13 L 1 - 1/8 Long Radius Elbow

▲ See Unit Dimensional Drawing for access hole location by number.

▼ Fittings are listed in order from header or tee stub connection out to access hole in corner support post.

Condensate Drain — Install a trapped condensate drain line to unit connection as shown in Fig. Condensate Drains. The unit drain connection is a PVC stub. See Fig. Drain Pan Slope Adjustment. Some areas may require an adapter to connect to either galvanized steel or copper pipe. For these applications, install a field-supplied threaded PVC adapter.

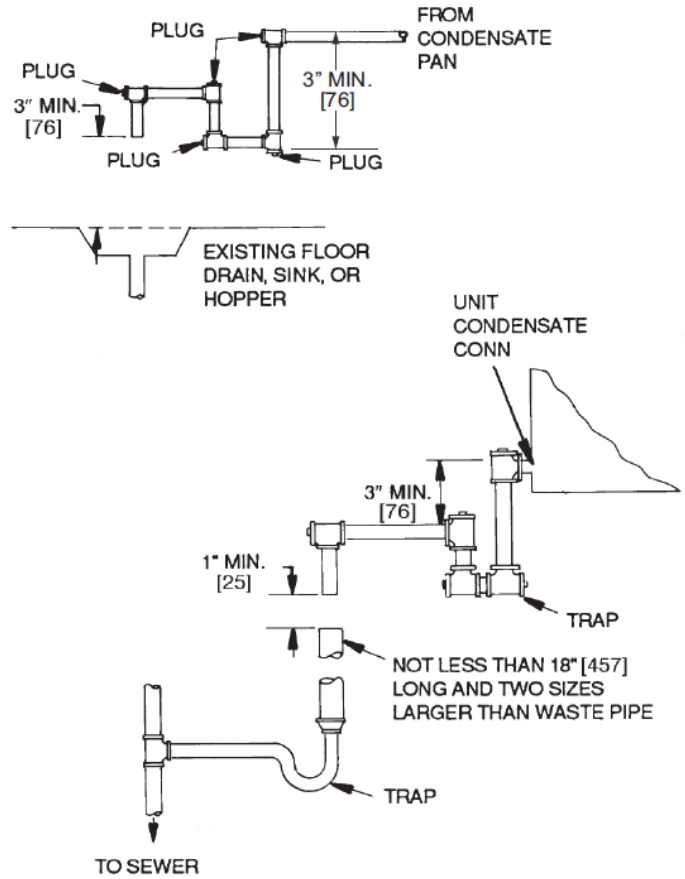

NOTE: Dimensions in [] are in millimeters

Condensate Drains

NOTE: A trap must be installed in the condensate drain line to ensure that the static pressure of fans is balanced with the water column in the drain line and that condensate can drain completely from pan. Without a trap, air can be drawn up drain line until water level in condensate pan becomes equal to static pressure created by fans, preventing complete drainage. Conditions will worsen as filters become dirty.

Install clean-out plugs in trap. Pitch drain line downward to an open floor drain or sump. Provide service clearance around drain line to permit removal of unit panels. Observe all local sanitary codes.

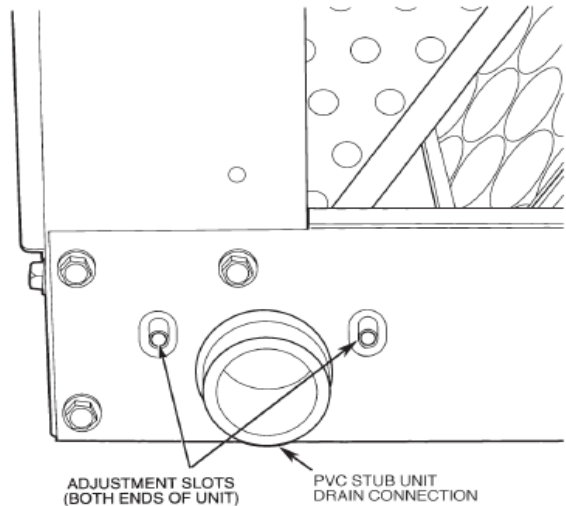

Drain Pan Slope Adjustment

As shipped, the unit's condensate drain pan is NOT sloped towards the drain connection. The pan slope must be changed to pitch towards the side of the unit with the drain connection. See Drain Pan Slope Adjustment Loosen the 2 screws next to the drain outlet at both ends of the unit, push drain pan down in the slots near the drain connection, and up in the slots on the opposite end. Re-tighten screws. The pan should have a pitch of at least 1/4-in. over its length toward the drain connection.

Fan Motor and Drives - Motor and drive packages are factory installed in all units. The motor and drive packages consist of the following items:

- 1 — fan motor
- 1 — adjustable motor pulley
- 1 — fan pulley
- 1 — fan belt

For instructions on changing fan rotation, changing drive speeds and adjusting drives, see Pulley and Drive Adjustment in the Service section.

Power Supply and Wiring -- Check the unit data plate to ensure that available power supply matches electrical characteristics of the unit. See Electrical Data Table for unit electrical data.



WARNING

ELECTRICAL OPERATION HAZARD

Failure to follow this warning could cause in personal injury or death.

Do not use gas piping as an electrical ground. Unit cabinet must have an uninterrupted, unbroken electrical ground to minimize the possibility of personal injury if an electrical fault should occur. This ground may consist of electrical wire connected to unit ground lug in control compartment, or conduit approved for electrical ground when installed in accordance with local electrical codes.

Install power wiring in accordance with all applicable local codes. See unit label diagram. For units with motor sizes less than 5 Hp (3.7 kW), connect power wiring to unit with no. 10 ring terminal. For units with motor sizes of 5 Hp (3.7 kW) or more, connect power wiring with 1/4--in. ring terminal.

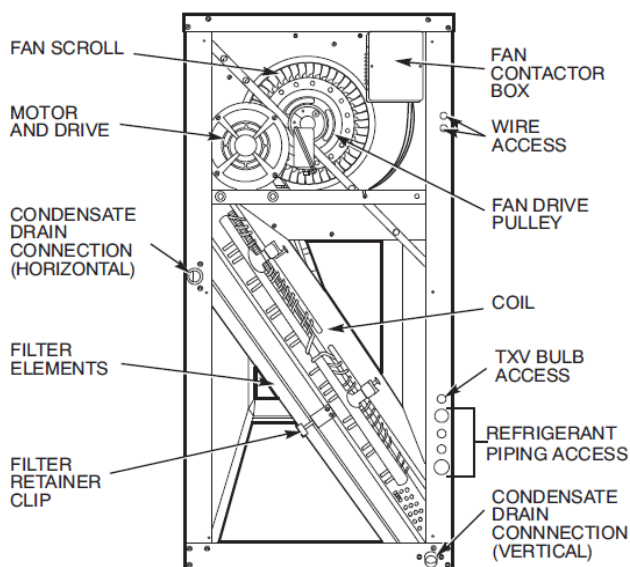

LEGEND
TXV — Thermostatic Expansion Valve

**Wiring and Service Access
(Side Panel Removed)**

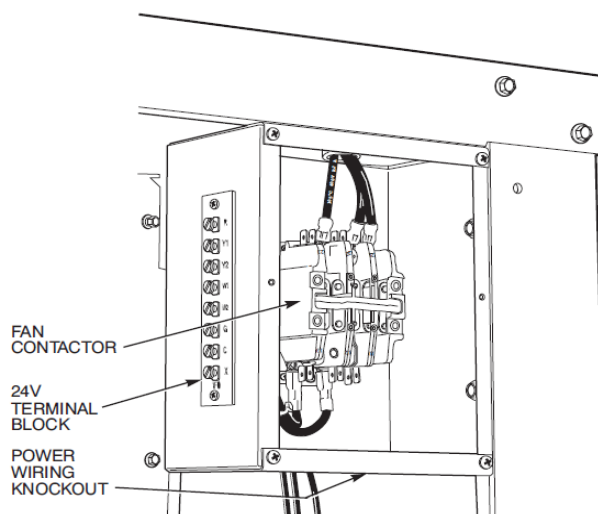

**Fan Contactor Box and Terminal
Block (Cover Removed) (Typical)**

Connecting Ductwork - Refer to the Carrier System Design Manual for the recommended design and layout of ductwork. Fig. Typical Fan Discharge Connections for Multiple Fan Units shows recommended duct connection to units with 2 fans.

 **WARNING**

UNIT OPERATION HAZARD

Failure to follow this caution could cause equipment damage.

Do not operate unit without ductwork or discharge plenum unless fan speed has been adjusted for external static pressure of zero in. wg. Failure to do so may result in motor overload.

DISCHARGE CONNECTIONS — Duct flanges are factory-supplied; they are shipped inside the unit attached to the hairpin end of the coil tube sheet for field installation. Using the existing screws, install the duct flanges on the unit's fan deck. Each fan discharge requires 2 flanges; each flange must be bent in the middle to conform to the discharge opening. See Duct Flange Installation. After flanges are installed, connect them to the supply duct using a canvas connection to prevent vibration. It is important that this connection be properly fabricated to prevent high air friction losses and air noise.

RETURN CONNECTIONS — When using return-air ductwork, route return-air duct to the unit's return air inlet near the filter rack, using a canvas connection to prevent transmission of unit vibration. If the duct blocks off the unit's access panel, provide a slip joint in the ductwork to permit removal for servicing.

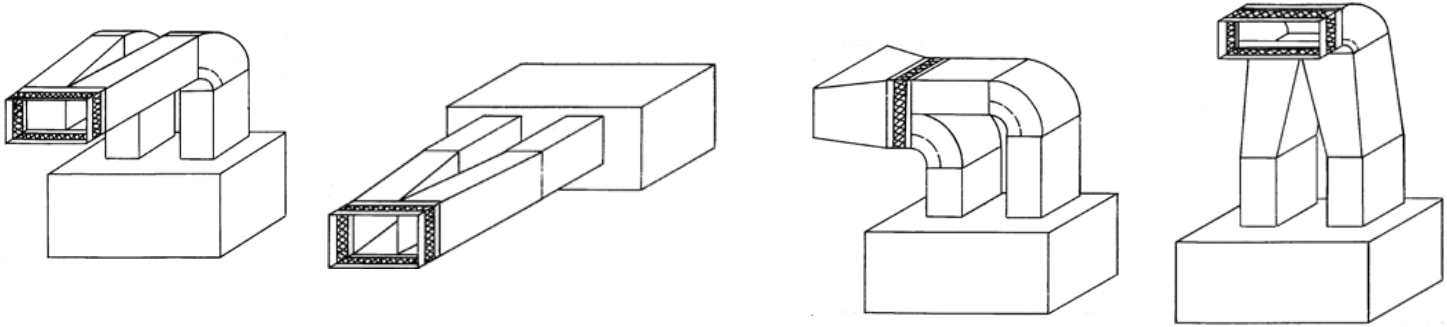

Typical Fan Discharge Connections for Multiple Fan Units

Return-Air Filters - Type and size of filters are shown in Tables 1A – 1F and are factory-supplied and factory-installed. In all units with 2 fans, a filter replacement tool (hook) is shipped inside the unit for field use when replacing filters. See the Service section for instructions on filter element replacement.

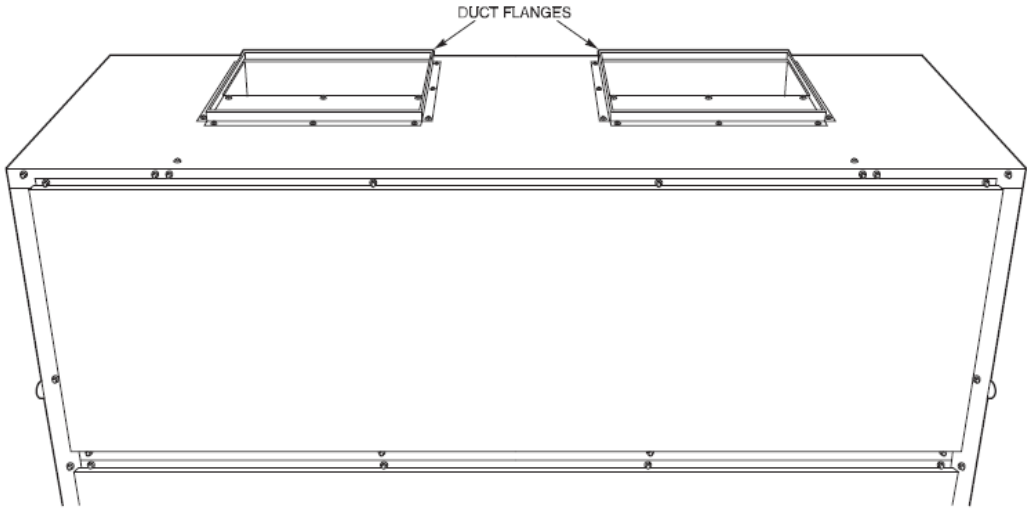

Duct Flange Installation

START-UP

Before starting unit, check the following and correct as necessary:

- Is unit solidly supported?
- Is fan adjusted for speed and pulley alignment?
- Are pulleys, motor, and bearings securely mounted?
- Are there any loose parts that will rattle or vibrate?
- Is condensate drain pan pitched for correct drainage?
- Are coil baffle plates tight against coil to prevent air bypass?
- Are all panels securely fastened?
- Are all electrical connections correct and tight?
- Is TXV bulb located on suction tube per Fig Face-Split Coil Suction and Liquid Line Piping (Typical)?
- Is the capillary tube to the bulb free of kinks and not subject to pinching?
- Is the bulb well secured to the suction tube with strap?

Also refer to condensing unit or outdoor heat pump section instructions before starting a split system. A split system start-up checklist is provided at the end of these instructions.

SERVICE

Inspection and maintenance should be performed at regular intervals and should include the following:

- Complete cleaning of cabinet, fan wheel, cooling coil, condensate pan and drain, heating coils, and return-air grille (if present).
- Inspection of panels and sealing of unit against air leakage.
- Adjustment of fan motor, belt, bearings, and wheels.
- Cleaning or replacement of filters.
- Testing for cooling/heating system leaks.
- Checking of all electrical connections.



WARNING

ELECTRICAL SHOCK HAZARD

Failure to follow this warning could result in personal injury or death.

Before performing service or maintenance operations on unit, always turn off main power switch to unit and install lockout tag. Unit may have more than one power switch.

Most unit service can be performed by removing one or both of the unit's side panels. Coil cleaning or removal or insulation cleaning may require removal of a rear, top, or bottom panel, depending on the unit's orientation. When service is completed, replace unit panels.

Panels - Panels are fastened to unit frame with sheet metal screws. Fan and coil compartment must be sealed tightly after service to prevent air from bypassing the cooling coil.

Fan Motor Lubrication - Fan motor supplied with unit is permanently lubricated and requires no further lubrication.

Fan Shaft Bearings - Bearings on size 07-12 units are sealed, permanently lubricated bearings that require no further lubrication. Size 14-16 units have pillow—block bearings (Fig. Fan Shaft, Bearings, and Fan Wheel (Typical)) that must be lubricated with suitable bearing grease approximately every 3 months. See below for suitable lubricants.

Manufacturer	Lubricant
Mobil	Mobilplex EP No. 2
Sunoco	Prestige 42
Texaco	Multifak 2
Texaco	Regal AFB - 2*

*Preferred lubricant, contains rust and oxidation inhibitors.

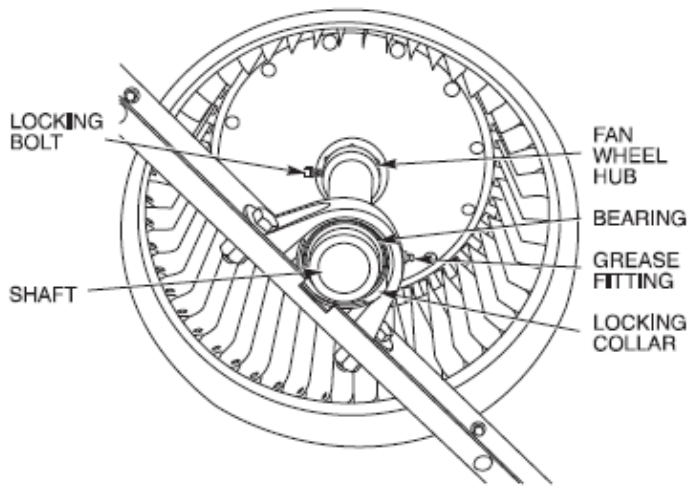

Fan Shaft, Bearings, and Fan Wheel (Typical)

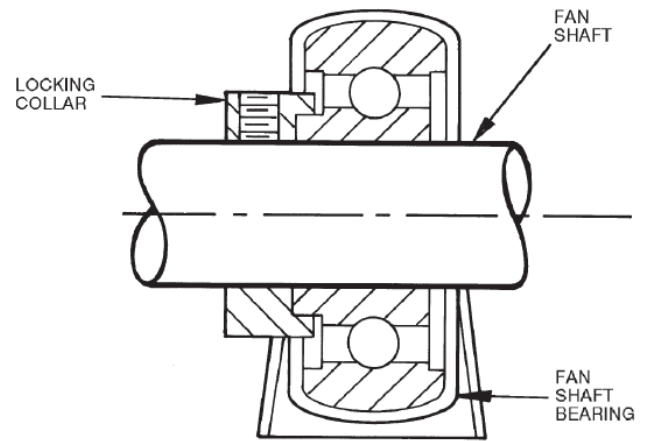

Fan Shaft Bearing

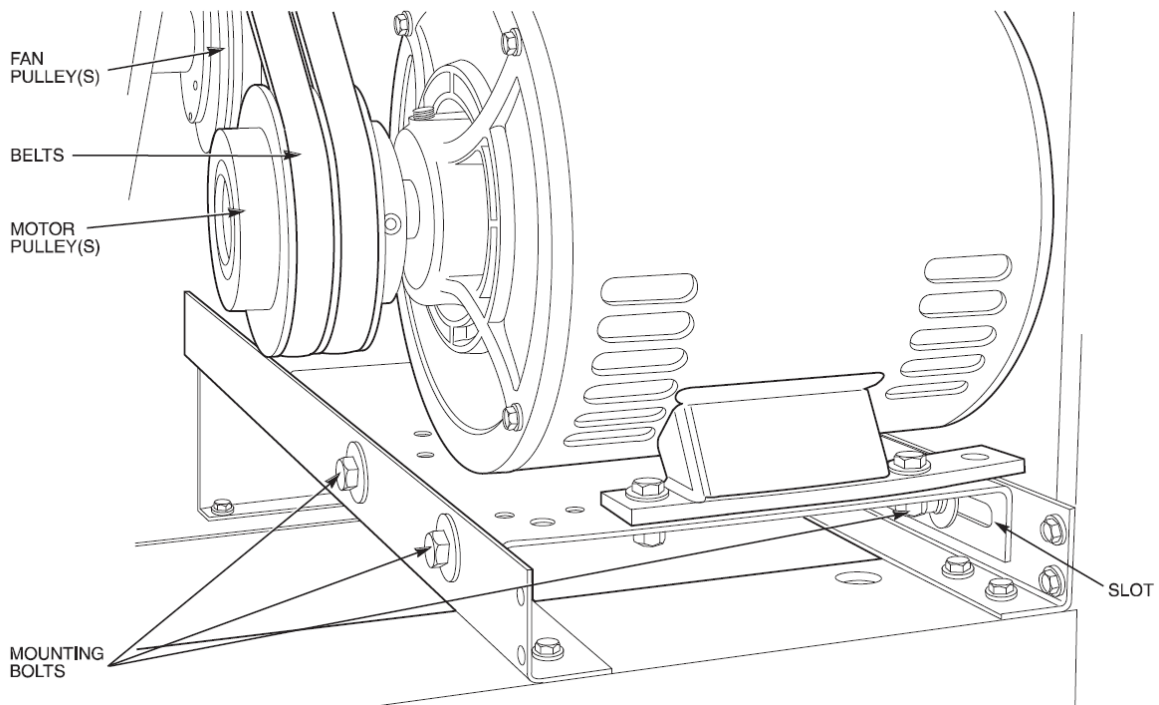

Fan Motor Mounting

Individual Fan Wheel Adjustment - Loosen the 2 locking bolts holding fan wheel hub to shaft. See (Fig. Fan Shaft, Bearings, and Fan Wheel (Typical)). Position fan wheel in center of the fan housing and tighten locking bolts. Clearance between wheel and housing should be the same on both sides.

Fan Belts - Motor mounting plate and motor support angles are slotted to permit both vertical and horizontal adjustment. Adjust belt(s) for correct deflection by loosening motor plate mounting bolts, moving motor/plate assembly forward or back, and re tightening bolts. Press down on belt with one finger midway between fan and motor pulleys to check deflection. For units with motor sizes up to and including 3.7 Hp (2.76 kW), correct deflection is 3/16-in. (4.8 mm). For larger motor sizes, correct deflection is 1/8-in. (3.2 mm). See Fig. Fan Motor Mounting. If complete belt replacement is required during servicing, loosen the motor plate mounting bolts, move motor/plate assembly towards fan pulley, and pull belt(s) off pulleys. Reverse the procedure with new bolts and readjust deflection.

Fan Rotation - Correct fan rotation with respect to fan outlet is shown in Fan Rotation. To reverse the direction of rotation of a 3-phase fan motor, reverse any 2 of the power leads. Refer to the connection diagram on the inside of motor terminal box cover for proper reversing procedure of single—phase motor.

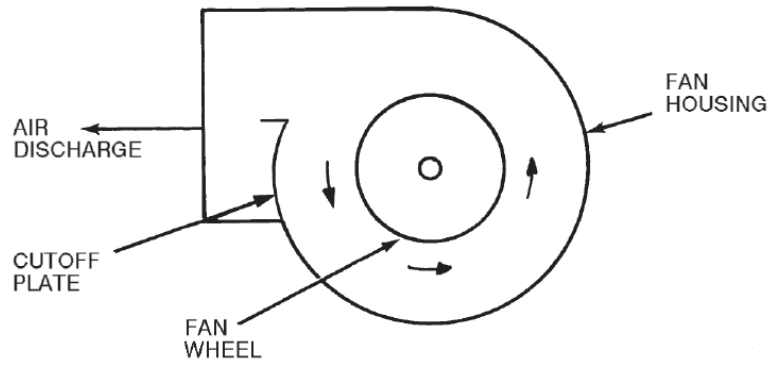

Fan Rotation

Fan Pulley Alignment - Align as follows:

1. Loosen setscrews on pulleys.
2. Align pulleys visually and tighten setscrews on fan pulley to lock it in place.
3. Use the methods shown in Fan Pulley Adjustments to check proper pulley alignment.
4. If pulleys are not in correct alignment, loosen the motor holddown bolts and slide the motor axially until the pulleys are aligned.
5. Tighten motor holddown bolts.

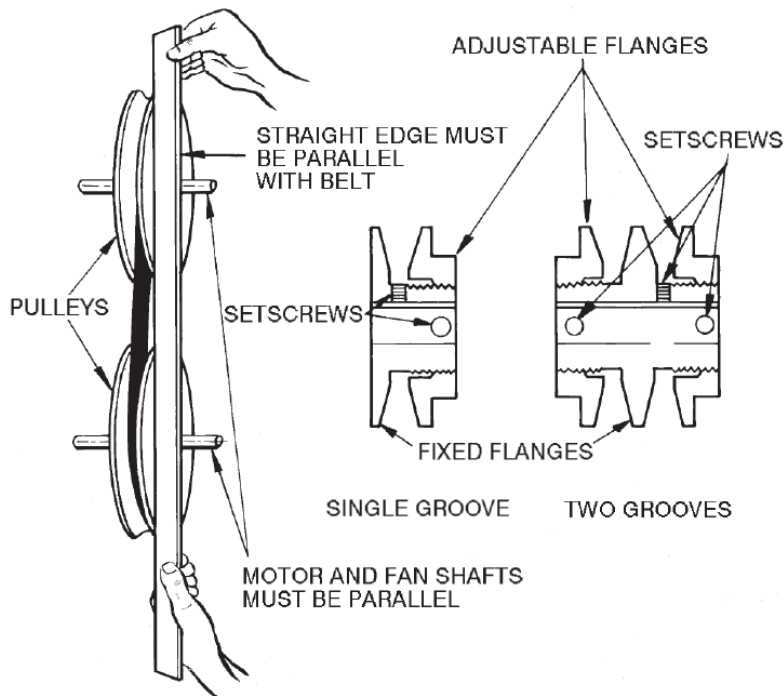

Fan Pulley Adjustments

Pulley and Drive Adjustment -- To obtain desired fan speed, refer to the fan motor and drive data in and adjust fan motor pulley as follows:

1. Remove belt from fan motor pulley after loosening motor from motor base.
2. Loosen setscrew in moveable flange of pulley. Screw moveable flange toward fixed flange to increase the fan speed and away from fixed flange to reduce speed. Before tightening setscrew, make certain that setscrew is over nearest flat surface of pulley hub as shown in Fan Pulley Adjustments.



WARNING

UNIT OPERATION HAZARD

Failure to follow this caution could cause equipment damage.

Increasing fan speed produces a greater load on motor. Do not exceed rated capacity of motor.

Condensate Drains - Keep condensate drains free of dirt and foreign matter.

Return-Air Filters - Refer to Replacing Filters section for filter accessibility and removal. Replace with clean filters of the sizes listed in Physical Data Table.

Coil Removal - Remove unit panels and corner posts as required. Disconnect coil connections and remove fastening screws. Remove coil through end or side sections of unit.

Cleaning Cooling Coil - Remove return-air filters. Remove any heavy dirt that may have accumulated on underside of coil. Coil can be cleaned more easily with a stiff brush, vacuum cleaner, or compressed air when coil is dry. If coil is wet or if water is to be used for cleaning, guard against splashing water on electrical components or damaging surrounding area. Clean coil baffles as applicable and check for tight fit to be sure air does not bypass coil.

Cleaning Insulation - The insulation contains an immobilized antimicrobial agent that helps prevent the growth of bacteria and fungi. Clean the inner surface of the insulation according to the separate maintenance instructions shipped with the unit.



WARNING

UNIT OPERATION HAZARD

Failure to follow this caution could cause equipment damage.

Do not operate unit without air filters.

Replacing Filters - Filters can be removed and installed from either side of the unit. Install new filters in units that have one fan as follows:

1. Remove the side access panel and panel end.
2. Push down Filter Latch and pull out Filter Cover Assy.
3. Remove old filters.
4. Reverse the procedure to install new filters.

To install new filters in larger units that have 2 fans, follow the below steps, but use the factory—supplied filter hook to slide filters within reach for removal. The filter hook is shipped inside the unit in the filter track.

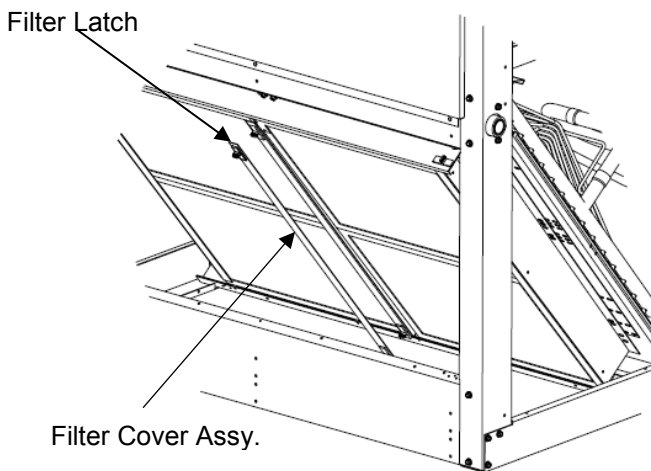

Remove Filter Retainer Clip

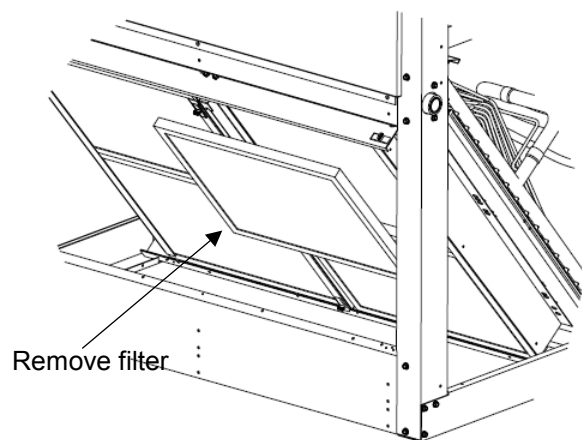

Filter Removal/Replacement

ELECTRICAL DATA TABLE

Standard Motors

Unit	Voltage	Voltage Range	Fan Motor		Power Supply	
			HP (kW)	FLA	MCA	MOCP
40RUM-07	400-3-50	360-440	2.4	2.6	3.3	15
40RUM-08	400-3-50	360-440	2.4	2.6	3.3	15
40RUM-12	400-3-50	360-440	2.9	3.8	4.3	15
40RUM-14	400-3-50	360-440	2.9	3.8	4.3	15
40RUM-16	400-3-50	360-440	2.9	3.8	4.3	15

Alternate Motors

Unit	Voltage	Voltage Range	Fan Motor		Power Supply	
			HP (kW)	FLA	MCA	MOCP
40RUM-07	400-3-50	360-440	2.4	2.6	3.3	15
40RUM-08	400-3-50	360-440	2.9	3.8	4.8	15
40RUM-12	400-3-50	360-440	5.0	8.0	10.0	15
40RUM-14	400-3-50	360-440	5.0	8.0	10.0	15
40RUM-16	400-3-50	360-440	5.0	8.0	10.0	15

Legend and Notes for Electrical Data Table

FLA - Full Load Amps

HP - Horse Power

kW - Kilowatt

MCA - Minimum Circuit Amps

MOCP - Maximum Overcurrent Protection

Application heater kW (Using multiplication factor table in Electric Resistance Heater Data Table)

Unbalanced 3-Phase Supply Voltage

Never operate a motor where phase imbalance in supply voltage is greater than 2%.

Use the following formula to determine the percentage of voltage imbalance

$$= 100 \times \frac{\text{Maximum Deviation From Average Voltage}}{\text{Average Voltage}}$$

Example: Supply Voltage is 400V - 3ph - 60Hz

AB = 392v	Average Voltage = $\frac{392 + 404 + 395}{3}$
BC = 404v	
AC = 395v	$= \frac{1191}{3} = 397V$

Determine maximum deviation from average voltage.

$$(AB) 397 - 392 = 5v$$

$$(BC) 404 - 397 = 7v$$

$$(AC) 457 - 397 = 2v$$

Maximum Deviation is 7v.

Determine Percentage Voltage Imbalance.

$$\% \text{ Voltage Imbalance} = 100 \times \frac{7}{397} = 1.76\%$$

This amount of phase imbalance is satisfactory as it is below the maximum allowable 2%

IMPORTANT: If the supply voltage phase imbalance is more than 2% contact your local electric utility company

ELECTRICAL HEATER DATA TABLE

Heater Part No. CAELHEAT	40RUM Size	V-Ph-Hz	Fan Motor			Electric Heater(s)					MCA	MOCP		
			Hp	kW	FLA	Nominal Capacity (kW)	Actual Capacity (kW)							
							Stage 1	Stage 2	Total	FLA				
002A00	07-12	400-3-50	2.4	1.79	2.6	5	3.5	—	3.5	5.0	9.5	15		
			2.9	2.16	3.4	5	3.5	—	3.5	5.0	10.5	15		
			5.0	3.73	7.6	5	3.5	—	3.5	5.0	15.8	20		
005A00			2.4	1.79	2.6	10	6.9	—	6.9	10.0	15.8	20		
			2.9	2.16	3.4	10	6.9	—	6.9	10.0	16.8	20		
			5.0	3.73	7.6	10	6.9	—	6.9	10.0	22.0	25		
008A00			2.4	1.79	2.6	15	10.4	—	10.4	15.0	22.0	25		
			2.9	2.16	3.4	15	10.4	—	10.4	15.0	23.0	25		
			5.0	3.73	7.6	15	10.4	—	10.4	15.0	28.3	30		
011A00			2.4	1.79	2.6	25	10.4	6.9	17.4	25.1	34.6	35		
			2.9	2.16	3.4	25	10.4	6.9	17.4	25.1	35.6	40		
			5.0	3.73	7.6	25	10.4	6.9	17.4	25.1	40.9	45		
014A00	08-12	400-3-50	2.4	1.79	2.6	35	13.9	10.4	24.3	35.1	47.1	50		
			2.9	2.16	3.4	35	13.9	10.4	24.3	35.1	48.1	50		
			5.0	3.73	7.6	35	13.9	10.4	24.3	35.1	53.4	60		
017A00			2.9	2.16	3.4	10	6.9	—	6.9	10.0	16.8	20		
			5.0	3.73	8.1	10	6.9	—	6.9	10.0	22.6	25		
			7.5	5.59	11.4	10	6.9	—	6.9	10.0	26.8	30		
020A00			14-16	400-3-50	10.0	5.59	15.1	10	6.9	—	6.9	10.0	31.4	35
					2.9	2.16	3.4	20	13.9	—	13.9	20.0	29.3	30
					2.9	2.16	3.4	20	13.9	—	13.9	28.9	40.4	45
					5.0	3.73	8.1	20	13.9	—	13.9	28.9	46.3	50
					5.0	3.73	8.1	20	13.9	—	13.9	28.9	46.3	50
					7.5	5.59	11.4	20	13.9	—	13.9	28.9	50.4	60
023A00	2.9	2.16			3.4	30	13.9	6.9	20.8	30.1	41.9	50		
	5.0	3.73			8.1	30	13.9	6.9	20.8	30.1	47.8	50		
	5.0	3.73			8.1	30	13.9	6.9	20.8	30.1	47.8	50		
026A00	16	400-3-50			7.5	5.59	11.4	30	13.9	6.9	20.8	30.1	51.9	60
					2.9	2.76	3.4	50	20.8	13.9	34.7	50.1	66.9	70
					5.0	3.73	8.1	50	20.8	13.9	34.7	50.1	72.8	80
7.5			5.59	11.4	50	20.8	13.9	34.7	50.1	76.9	80			

Legend and Notes for Electrical Data Table

FLA - Full Load Amps

HP - Horse Power

kW - Kilowatt

MCA - Minimum Circuit Amps

MOCP - Maximum Overcurrent Protection



1. Heater contactor coils are 24 v and require 8 va holding current.
2. Electric heaters are tested and ETL approved at maximum total external static pressure of 1.9 in. wg.
3. MCA and MOCP values apply to both standard and alternate factory-supplied motors.
4. Approximate shipping weight for CAELHEAT002A00-014A00 is 55 lb (25 kg) and for CAELHEAT017A00-026A00 is 60 lb (27 kg)

TYPICAL WIRING SCHEMATIC

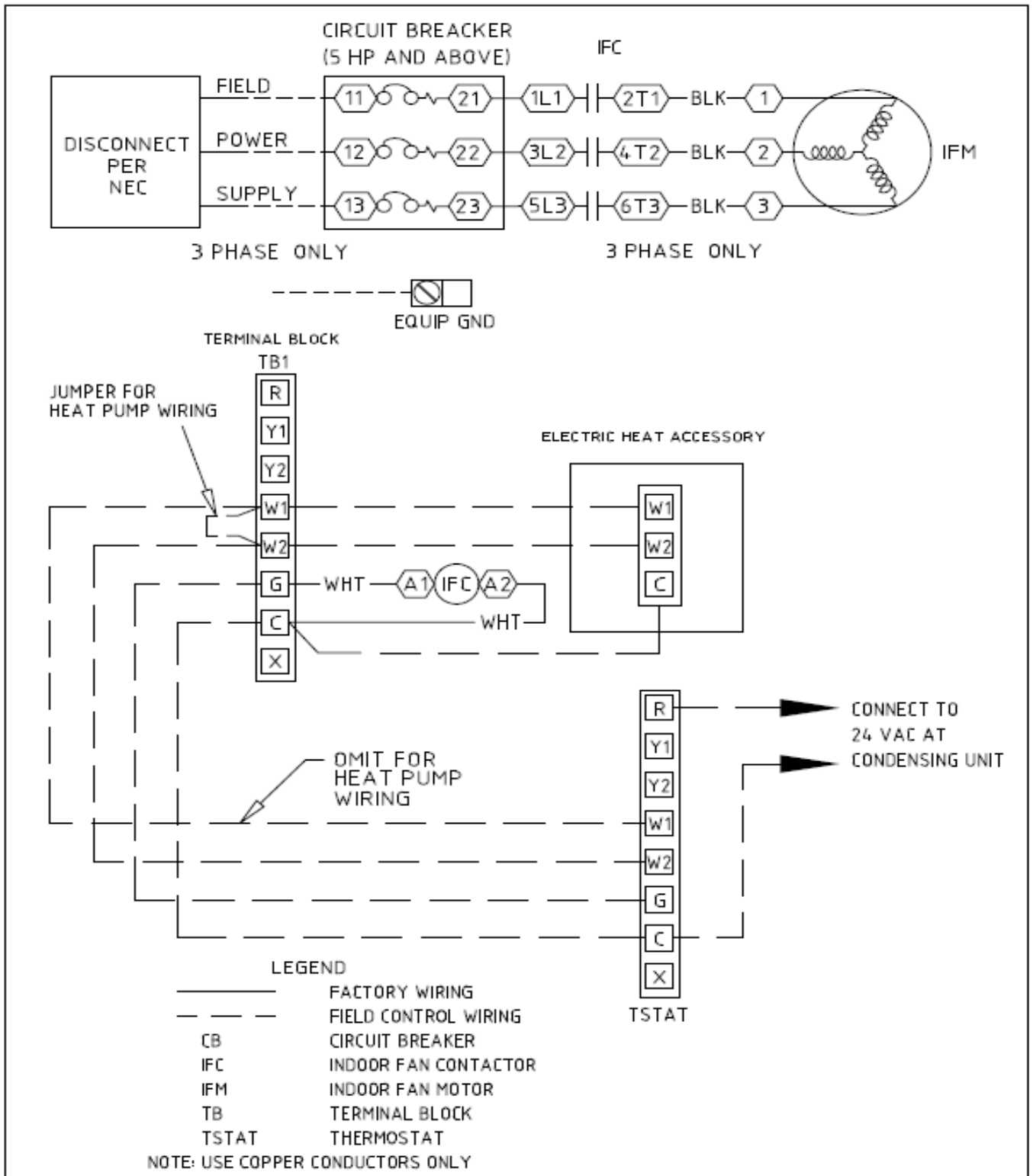

40RUM Unit Size 7 – 16

FAN PERFORMANCE DATA - English

Unit 40RUM	Airflow (Cfm)	External Static Pressure (in. wg)													
		0.0		0.2		0.4		0.6		0.8		1.0		1.2	
		Rpm	Bhp	Rpm	Bhp	Rpm	Bhp	Rpm	Bhp	Rpm	Bhp	Rpm	Bhp	Rpm	Bhp
7	1,800	399	0.19	454	0.24	548	0.35	<u>634</u>	<u>0.47</u>	713	<u>0.6</u>	785	0.74	850	<u>0.89</u>
	2,100	446	0.28	497	0.34	583	0.46	<u>660</u>	<u>0.59</u>	733	<u>0.73</u>	<u>802</u>	<u>0.88</u>	<u>867</u>	<u>1.05</u>
	2,400	498	0.40	541	0.47	<u>622</u>	<u>0.60</u>	<u>693</u>	<u>0.74</u>	<u>760</u>	<u>0.89</u>	<u>824</u>	<u>1.05</u>	<u>885</u>	<u>1.22</u>
	2,700	544	0.55	588	0.63	<u>663</u>	<u>0.78</u>	<u>730</u>	<u>0.93</u>	<u>792</u>	<u>1.09</u>	<u>851</u>	<u>1.26</u>	<u>909</u>	<u>1.44</u>
	3,000	594	0.73	<u>635</u>	<u>0.82</u>	<u>707</u>	<u>0.99</u>	<u>770</u>	<u>1.15</u>	<u>828</u>	<u>1.32</u>	<u>883</u>	1.50	<u>937</u>	<u>1.69</u>
8	2,250	273	0.08	493	0.37	580	0.49	656	0.62	<u>727</u>	<u>0.76</u>	794	0.92	858	1.08
	2,600	322	0.15	540	0.52	<u>622</u>	0.66	<u>693</u>	<u>0.81</u>	<u>757</u>	<u>0.96</u>	<u>819</u>	<u>1.12</u>	<u>878</u>	<u>1.29</u>
	3,000	552	0.65	595	0.73	673	0.91	<u>740</u>	<u>1.07</u>	<u>800</u>	<u>1.24</u>	<u>856</u>	<u>1.41</u>	<u>910</u>	<u>1.60</u>
	3,400	615	0.91	653	1.01	<u>726</u>	1.21	<u>789</u>	<u>1.40</u>	<u>846</u>	<u>1.59</u>	<u>899</u>	<u>1.78</u>	<u>950</u>	<u>1.97</u>
	3,750	671	1.20	<u>706</u>	<u>1.31</u>	<u>773</u>	<u>1.53</u>	<u>834</u>	<u>1.74</u>	<u>889</u>	<u>1.95</u>	<u>940</u>	2.16	<u>988</u>	<u>2.37</u>
12	3,000	399	0.29	573	0.69	654	0.86	722	1.03	784	1.19	<u>841</u>	<u>1.37</u>	<u>896</u>	<u>1.55</u>
	3,500	604	0.92	641	1.02	714	1.22	780	1.42	<u>838</u>	<u>1.61</u>	<u>892</u>	<u>1.81</u>	<u>942</u>	<u>2.01</u>
	4,000	680	1.33	713	1.45	778	1.68	<u>839</u>	<u>1.91</u>	<u>896</u>	<u>2.14</u>	<u>947</u>	<u>2.36</u>	<u>995</u>	<u>2.58</u>
	4,500	756	1.86	<u>787</u>	<u>1.99</u>	<u>845</u>	<u>2.26</u>	<u>901</u>	<u>2.52</u>	<u>955</u>	<u>2.78</u>	<u>1005</u>	<u>3.03</u>	<u>1051</u>	<u>3.28</u>
	5,000	<u>834</u>	<u>2.51</u>	<u>861</u>	<u>2.67</u>	<u>914</u>	<u>2.96</u>	<u>966</u>	<u>3.25</u>	<u>1016</u>	<u>3.54</u>	<u>1064</u>	3.82	1109	4.11
14	3,750	394	0.40	453	0.52	558	0.80	643	1.10	<u>717</u>	<u>1.39</u>	<u>785</u>	<u>1.71</u>	<u>848</u>	<u>2.04</u>
	4,300	436	0.57	487	0.70	586	1.00	670	1.34	<u>742</u>	<u>1.67</u>	<u>806</u>	<u>2.01</u>	<u>867</u>	<u>2.36</u>
	5,000	492	0.86	535	0.99	623	1.31	<u>704</u>	<u>1.69</u>	<u>775</u>	<u>2.08</u>	<u>838</u>	<u>2.47</u>	<u>896</u>	<u>2.86</u>
	5,700	550	1.23	587	1.37	664	1.71	<u>740</u>	<u>2.11</u>	<u>809</u>	<u>2.55</u>	<u>872</u>	<u>2.99</u>	<u>929</u>	<u>3.43</u>
	6,250	596	1.59	630	1.74	<u>700</u>	<u>2.09</u>	<u>770</u>	<u>2.51</u>	<u>837</u>	<u>2.97</u>	<u>899</u>	3.45	<u>955</u>	<u>3.94</u>
16	4,500	428	0.59	475	0.70	570	0.99	656	1.33	<u>730</u>	<u>1.68</u>	<u>796</u>	<u>2.02</u>	<u>856</u>	<u>2.38</u>
	5,300	488	0.92	528	1.04	609	1.34	689	1.71	<u>762</u>	<u>2.11</u>	<u>827</u>	<u>2.51</u>	<u>886</u>	<u>2.92</u>
	6,000	542	1.29	578	1.43	649	1.74	<u>721</u>	<u>2.11</u>	<u>791</u>	<u>2.55</u>	<u>855</u>	<u>3.00</u>	<u>914</u>	<u>3.46</u>
	6,800	604	1.83	637	1.99	<u>700</u>	<u>2.32</u>	<u>763</u>	<u>2.70</u>	<u>826</u>	<u>3.15</u>	<u>888</u>	<u>3.64</u>	<u>946</u>	<u>4.15</u>
	7,500	660	2.42	690	2.59	<u>747</u>	<u>2.95</u>	<u>804</u>	<u>3.34</u>	<u>861</u>	<u>3.79</u>	<u>919</u>	<u>4.29</u>	<u>975</u>	<u>4.83</u>

Unit 40RUM	Airflow (Cfm)	External Static Pressure (in. wg)											
		1.4		1.6		1.8		2.0		2.2		2.4	
		Rpm	Bhp	Rpm	Bhp	Rpm	Bhp	Rpm	Bhp	Rpm	Bhp	Rpm	Bhp
7	1,800	910	1.04	965	1.20	1016	1.36	1065	1.52	1111	1.69	1155	1.86
	2,100	<u>927</u>	<u>1.21</u>	<u>983</u>	<u>1.38</u>	<u>1035</u>	<u>1.56</u>	1084	1.74	1131	1.92	1175	2.11
	2,400	<u>944</u>	<u>1.41</u>	<u>999</u>	<u>1.59</u>	1052	1.78	1101	1.98	1149	2.18	1193	2.38
	2,700	964	<u>1.63</u>	<u>1018</u>	<u>1.82</u>	1069	2.03	1118	2.24	1165	2.45	—	—
	3,000	<u>989</u>	<u>1.89</u>	<u>1039</u>	<u>2.10</u>	1089	2.31	1136	2.53	1183	2.76	—	—
8	2,250	918	1.26	975	1.43	1029	1.62	1079	1.80	1126	1.99	1172	2.18
	2,600	<u>936</u>	<u>1.48</u>	<u>991</u>	<u>1.67</u>	<u>1044</u>	<u>1.87</u>	<u>1094</u>	<u>2.07</u>	1142	2.28	1188	2.49
	3,000	<u>963</u>	<u>1.79</u>	<u>1014</u>	<u>1.99</u>	<u>1064</u>	<u>2.20</u>	<u>1113</u>	<u>2.42</u>	1159	2.64	—	—
	3,400	998	<u>2.18</u>	<u>1045</u>	<u>2.39</u>	<u>1092</u>	<u>2.61</u>	<u>1137</u>	<u>2.83</u>	1182	3.07	—	—
	3,750	<u>1034</u>	<u>2.58</u>	<u>1078</u>	<u>2.80</u>	<u>1122</u>	<u>3.03</u>	1164	3.27	—	—	—	—
12	3,000	949	1.74	1000	1.93	1050	2.14	1099	2.36	1147	2.58	1192	2.81
	3,500	<u>990</u>	<u>2.21</u>	<u>1037</u>	<u>2.42</u>	<u>1083</u>	<u>2.64</u>	1128	2.86	1172	3.1	—	—
	4,000	<u>1040</u>	<u>2.80</u>	<u>1084</u>	<u>3.03</u>	<u>1126</u>	<u>3.26</u>	1167	3.50	—	—	—	—
	4,500	<u>1094</u>	<u>3.53</u>	<u>1136</u>	<u>3.78</u>	<u>1176</u>	<u>4.03</u>	—	—	—	—	—	—
	5,000	<u>1151</u>	<u>4.39</u>	<u>1191</u>	<u>4.66</u>	—	—	—	—	—	—	—	—
14	3,750	909	2.37	968	2.74	1026	3.12	1080	3.51	1131	3.92	1181	4.32
	4,300	<u>925</u>	<u>2.73</u>	<u>980</u>	<u>3.11</u>	<u>1034</u>	<u>3.52</u>	1084	3.92	1135	4.35	1184	4.78
	5,000	<u>950</u>	<u>3.26</u>	<u>1002</u>	<u>3.67</u>	1052	4.09	1101	4.53	1148	4.98	1190	5.44
	5,700	981	<u>3.88</u>	<u>1031</u>	<u>4.33</u>	1079	4.79	1125	5.25	1169	5.73	—	—
	6,250	<u>1007</u>	<u>4.42</u>	1057	4.91	1103	5.4	1148	5.90	1191	6.40	—	—
16	4,500	912	2.75	967	3.13	1019	3.52	1070	3.92	1120	4.35	1168	4.79
	5,300	<u>940</u>	<u>3.33</u>	<u>992</u>	<u>3.75</u>	1041	4.18	1088	4.61	1134	5.06	1179	5.52
	6,000	<u>968</u>	<u>3.92</u>	<u>1018</u>	<u>4.38</u>	1066	4.85	1112	5.32	1156	5.80	1198	6.29
	6,800	<u>1000</u>	<u>4.67</u>	1050	5.19	1097	5.71	1142	6.23	1185	6.76	—	—
	7,500	1028	5.39	1078	5.97	1125	6.54	1170	7.11	—	—	—	—

LEGEND

Bhp — Brake Horsepower Input to Fan

ESP — External Static Pressure

Bold indicates field-supplied drive or motor is required. Plain type indicates standard motor and standard drive.

Underline indicates a different motor and drive combination other than the standard motor and standard drive combination is required. Refer to fan motor and drive tables to complete selection.

NOTES:

Maximum allowable fan speed is 1200 rpm for all sizes. Fan performance is based on deductions for wet coil, clean 1-in. filters, and unit casing. See table below for factory-supplied filter pressure drop.

FAN PERFORMANCE DATA (cont.) - SI

Unit 40RUM	Airflow (L/s)	External Static Pressure (Pa)													
		0		50		100		150		200		250		300	
		r/s	kW	r/s	kW	r/s	kW	r/s	kW	r/s	kW	r/s	kW	r/s	kW
7	850	6.64	0.14	7.56	0.18	9.13	0.26	<u>10.56</u>	<u>0.35</u>	11.88	0.45	13.08	0.55	14.16	0.66
	990	7.43	0.21	8.28	0.25	9.71	0.34	<u>11.00</u>	<u>0.44</u>	<u>12.22</u>	<u>0.54</u>	13.37	0.66	14.44	0.78
	1130	8.30	0.30	9.02	0.35	<u>10.36</u>	<u>0.45</u>	<u>11.55</u>	<u>0.55</u>	<u>12.67</u>	<u>0.66</u>	<u>13.73</u>	<u>0.78</u>	<u>14.76</u>	<u>0.91</u>
	1270	9.06	0.41	9.79	0.47	<u>11.06</u>	<u>0.58</u>	<u>12.17</u>	<u>0.69</u>	<u>13.2</u>	<u>0.81</u>	<u>14.19</u>	<u>0.94</u>	<u>15.14</u>	<u>1.07</u>
	1420	9.91	0.55	<u>10.58</u>	<u>0.61</u>	<u>11.78</u>	<u>0.74</u>	<u>12.83</u>	<u>0.86</u>	<u>13.8</u>	<u>0.99</u>	<u>14.72</u>	<u>1.12</u>	<u>15.61</u>	<u>1.26</u>
8	1060	4.55	0.06	8.21	0.27	9.67	0.37	10.93	0.46	12.11	0.57	13.23	0.68	14.30	0.81
	1230	5.37	0.11	8.99	0.38	10.37	0.49	<u>11.55</u>	<u>0.6</u>	<u>12.62</u>	<u>0.71</u>	<u>13.65</u>	<u>0.84</u>	<u>14.64</u>	<u>0.96</u>
	1420	9.21	0.48	9.92	0.55	11.22	0.67	<u>12.33</u>	<u>0.8</u>	<u>13.33</u>	<u>0.92</u>	<u>14.27</u>	<u>1.05</u>	<u>15.17</u>	<u>1.19</u>
	1600	10.25	0.68	10.89	0.75	<u>12.09</u>	<u>0.90</u>	<u>13.15</u>	<u>1.04</u>	<u>14.1</u>	<u>1.18</u>	<u>14.99</u>	<u>1.33</u>	<u>15.83</u>	<u>1.47</u>
	1770	11.18	0.90	<u>11.76</u>	<u>0.98</u>	<u>12.88</u>	<u>1.14</u>	<u>13.90</u>	<u>1.30</u>	<u>14.82</u>	<u>1.45</u>	<u>15.67</u>	<u>1.61</u>	<u>16.46</u>	<u>1.77</u>
12	1420	6.65	0.22	9.55	0.51	10.89	0.64	12.04	0.77	13.06	0.89	<u>14.02</u>	<u>1.02</u>	<u>14.93</u>	<u>1.15</u>
	1650	10.06	0.68	10.69	0.76	11.9	0.91	13.00	1.06	<u>13.97</u>	<u>1.20</u>	<u>14.86</u>	<u>1.35</u>	<u>15.7</u>	<u>1.50</u>
	1890	11.33	0.99	11.88	1.08	12.96	1.25	<u>13.99</u>	<u>1.43</u>	<u>14.93</u>	<u>1.59</u>	<u>15.78</u>	<u>1.76</u>	<u>16.58</u>	<u>1.92</u>
	2120	12.61	1.38	<u>13.11</u>	<u>1.49</u>	<u>14.08</u>	<u>1.68</u>	<u>15.02</u>	<u>1.88</u>	<u>15.92</u>	<u>2.07</u>	<u>16.74</u>	<u>2.26</u>	<u>17.51</u>	<u>2.44</u>
	2360	13.90	1.87	<u>14.36</u>	<u>1.99</u>	<u>15.23</u>	<u>2.21</u>	<u>16.10</u>	<u>2.42</u>	<u>16.94</u>	<u>2.64</u>	<u>17.73</u>	<u>2.85</u>	<u>18.48</u>	<u>3.06</u>
14	1770	6.57	0.30	7.54	0.39	9.31	0.60	10.72	0.82	11.95	1.04	13.09	1.27	14.13	1.52
	2030	7.27	0.43	8.11	0.52	9.76	0.75	11.16	1.00	12.36	1.25	13.44	1.50	14.45	1.76
	2360	8.20	0.64	8.92	0.74	10.38	0.98	<u>11.73</u>	<u>1.26</u>	<u>12.91</u>	<u>1.55</u>	<u>13.97</u>	<u>1.84</u>	<u>14.93</u>	<u>2.13</u>
	2690	9.16	0.92	9.79	1.02	11.07	1.27	<u>12.33</u>	<u>1.58</u>	<u>13.48</u>	<u>1.90</u>	<u>14.53</u>	<u>2.23</u>	<u>15.48</u>	<u>2.56</u>
	2950	9.93	1.18	10.50	1.30	11.66	1.56	<u>12.83</u>	<u>1.87</u>	<u>13.95</u>	<u>2.22</u>	<u>14.98</u>	<u>2.58</u>	<u>15.92</u>	<u>2.94</u>
16	2120	7.13	0.44	7.91	0.52	9.50	0.74	10.94	0.99	<u>12.17</u>	<u>1.25</u>	<u>13.26</u>	<u>1.51</u>	<u>14.26</u>	<u>1.77</u>
	2500	8.13	0.68	8.80	0.78	10.15	1.00	11.48	1.27	<u>12.7</u>	<u>1.57</u>	<u>13.78</u>	<u>1.87</u>	<u>14.76</u>	<u>2.18</u>
	2830	9.03	0.96	9.63	1.07	10.81	1.30	<u>12.01</u>	<u>1.58</u>	<u>13.18</u>	<u>1.90</u>	<u>14.25</u>	<u>2.24</u>	<u>15.23</u>	<u>2.58</u>
	3210	10.07	1.37	10.62	1.48	<u>11.66</u>	<u>1.73</u>	<u>12.71</u>	<u>2.01</u>	<u>13.77</u>	<u>2.35</u>	<u>14.8</u>	<u>2.71</u>	<u>15.76</u>	<u>3.09</u>
	3540	10.99	1.81	11.50	1.93	<u>12.45</u>	<u>2.20</u>	<u>13.40</u>	<u>2.49</u>	<u>14.35</u>	<u>2.83</u>	<u>15.31</u>	<u>3.20</u>	<u>16.24</u>	<u>3.60</u>

Unit 40RUM	Airflow (L/s)	External Static Pressure (Pa)											
		350		400		450		500		550		600	
		r/s	kW	r/s	kW	r/s	kW	r/s	kW	r/s	kW	r/s	kW
7	850	<u>15.16</u>	<u>0.78</u>	16.08	<u>0.89</u>	16.94	1.01	17.74	1.13	18.51	1.26	19.25	1.39
	990	<u>15.44</u>	<u>0.90</u>	16.38	<u>1.03</u>	<u>17.25</u>	<u>1.16</u>	18.07	1.30	18.84	1.43	19.58	1.57
	1130	<u>15.73</u>	<u>1.05</u>	<u>16.65</u>	<u>1.19</u>	17.53	1.33	18.36	1.48	19.14	1.62	19.89	1.77
	1270	<u>16.07</u>	<u>1.21</u>	16.96	1.36	17.82	1.51	18.64	1.67	19.42	1.83	—	—
	1420	<u>16.48</u>	<u>1.41</u>	<u>17.32</u>	<u>1.56</u>	18.14	1.72	18.94	1.89	19.71	2.06	—	—
8	1060	15.31	<u>0.94</u>	16.25	1.07	17.14	1.20	17.98	1.34	18.77	1.48	19.53	1.63
	1230	<u>15.60</u>	<u>1.10</u>	16.51	1.24	<u>17.39</u>	<u>1.39</u>	<u>18.23</u>	<u>1.54</u>	19.03	1.70	19.80	1.86
	1420	<u>16.05</u>	<u>1.33</u>	16.9	1.48	<u>17.74</u>	<u>1.64</u>	<u>18.54</u>	<u>1.8</u>	19.32	1.97	—	—
	1600	<u>16.64</u>	<u>1.62</u>	<u>17.42</u>	<u>1.78</u>	<u>18.2</u>	<u>1.94</u>	<u>18.95</u>	<u>2.11</u>	19.69	2.29	—	—
	1770	<u>17.23</u>	<u>1.93</u>	<u>17.97</u>	<u>2.09</u>	<u>18.7</u>	<u>2.26</u>	19.41	2.44	—	—	—	—
12	1420	<u>15.81</u>	<u>1.29</u>	<u>16.67</u>	<u>1.44</u>	<u>17.51</u>	<u>1.60</u>	18.32	1.76	19.11	1.92	19.87	2.09
	1650	<u>16.51</u>	<u>1.65</u>	<u>17.29</u>	<u>1.80</u>	<u>18.05</u>	<u>1.97</u>	18.80	2.13	19.53	2.31	—	—
	1890	<u>17.34</u>	<u>2.09</u>	<u>18.06</u>	<u>2.26</u>	<u>18.77</u>	<u>2.43</u>	19.45	2.61	—	—	—	—
	2120	<u>18.24</u>	<u>2.63</u>	<u>18.93</u>	<u>2.82</u>	<u>19.59</u>	<u>3.00</u>	—	—	—	—	—	—
	2360	19.18	<u>3.27</u>	<u>19.85</u>	<u>3.48</u>	—	—	—	—	—	—	—	—
14	1770	<u>15.15</u>	<u>1.77</u>	<u>16.13</u>	<u>2.04</u>	<u>17.1</u>	<u>2.33</u>	18.00	2.62	18.85	2.92	19.68	3.22
	2030	<u>15.41</u>	<u>2.04</u>	<u>16.34</u>	<u>2.32</u>	<u>17.24</u>	<u>2.62</u>	18.07	2.92	18.92	3.24	19.73	3.56
	2360	<u>15.84</u>	<u>2.43</u>	<u>16.7</u>	<u>2.74</u>	17.54	3.05	18.35	3.38	19.14	3.71	19.83	4.06
	2690	<u>16.36</u>	<u>2.89</u>	<u>17.19</u>	<u>3.23</u>	17.98	3.57	18.75	3.92	19.49	4.27	—	—
	2950	16.79	3.30	17.61	3.66	18.39	4.03	19.13	4.40	19.84	4.77	—	—
16	2120	<u>15.20</u>	<u>2.05</u>	<u>16.12</u>	<u>2.33</u>	16.98	2.62	17.83	2.92	18.67	3.24	19.47	3.57
	2500	<u>15.67</u>	<u>2.49</u>	<u>16.53</u>	<u>2.80</u>	17.35	3.12	18.13	3.44	18.90	3.77	19.65	4.12
	2830	<u>16.13</u>	<u>2.92</u>	<u>16.97</u>	<u>3.27</u>	17.77	3.62	18.53	3.97	19.26	4.33	19.97	4.69
	3210	<u>16.66</u>	<u>3.48</u>	17.50	3.87	18.29	4.26	19.03	4.65	19.75	5.04	—	—
	3540	17.13	4.02	17.97	4.45	18.75	4.88	19.50	5.30	—	—	—	—

LEGEND

Bhp — Brake Horsepower Input to Fan

ESP — External Static Pressure

Bold indicates field-supplied drive or motor is required. Plain type indicates standard motor and standard drive.

Underline indicates a different motor and drive combination other than the standard motor and standard drive combination is required. Refer to fan motor and drive tables to complete selection.

NOTES:

Maximum allowable fan speed is 20 r/s for all sizes. Fan performance is based on deductions for wet coil, clean 25.4-mm filters, and unit casing. See table below for factory-supplied filter pressure drop.

PERFORMANCE DATA

Factory-Supplied Filter Pressure Drop — English

Unit 40RUM	Airflow (Cfm)	Pressure Drop (in. wg)
7	1800	0.05
	2400	0.08
	3000	0.11
8	2250	0.07
	3000	0.11
	3750	0.15
12	3000	0.11
	4000	0.17
	5000	0.23
14	3750	0.06
	5000	0.10
	6250	0.13
16	4500	0.08
	6000	0.12
	7500	0.17

Factory-Supplied Filter Pressure Drop — SI

Unit 40RUM	Airflow (L/s)	Pressure Drop (Pa)
7	850	13
	1150	20
	1450	28
8	1000	17
	1400	27
	1800	38
12	1450	28
	1900	42
	2350	56
14	1750	15
	2350	24
	2950	33
16	2100	20
	2800	30
	3500	42

Accessory Plenum Air Throw Data — English (Ft)

Unit 40RUM	Airflow (Cfm)	Vane Deflection		
		Straight	21 °	45°
7	2400	39	33	24
8	3000	45	38	28
12	4000	55	46	33
14	5000	45	38	28
16	6000	50	43	31

TERMINAL VELOCITY (Fpm)	THROW FACTOR
50	X 1.50
100	X 0.75
150	X 0.50

NOTE: Throw distances shown are for 75 fpm terminal velocity. Use the following multipliers to determine throw values for other terminal velocities.

Accessory Plenum Air Throw Data — SI (m)

Unit 40RUM	Airflow (L/s)	Vane Deflection		
		Straight	21 °	45°
7	1150	11.71	9.91	7.20
8	1400	13.87	11.71	8.63
12	1900	16.65	13.93	9.99
14	2350	13.77	11.63	8.57
16	2800	15.41	13.25	9.55

TERMINAL VELOCITY (m/sec)	THROW FACTOR
0.254	X 1.50
0.508	X 0.75
0.762	X 0.50

NOTE: Throw distances shown are for 0.381 m/sec terminal velocity. Use the following multipliers to determine throw values for other terminal velocities.

Accessory Pressure Drop — English (in. wg)

Unit	Airflow (Cfm)	Discharge Plenum	Electric Heater	Return Air Grille
7	1800	0.06	0.04	0.01
	2400	0.10	0.06	0.01
	3000	0.14	0.10	0.02
8	2250	0.09	0.06	0.01
	3000	0.14	0.10	0.02
	3750	0.21	0.15	0.03
12	3000	0.14	0.10	0.02
	4000	0.22	0.17	0.04
	5000	0.32	0.26	0.06
14	3750	0.07	0.04	0.01
	5000	0.12	0.07	0.02
	6250	0.17	0.11	0.02
16	4500	0.10	0.06	0.01
	6000	0.16	0.10	0.02
	7500	0.23	0.15	0.03

Accessory Pressure Drop — SI (Pa)

Unit	Airflow (L/s)	Discharge Plenum	Electric Heater	Return Air Grille
7	850	15	9	2
	1150	25	16	3
	1450	36	26	5
8	1000	20	12	2
	1400	34	24	5
	1800	51	39	8
12	1450	36	26	5
	1900	56	43	10
	2350	79	65	15
14	1750	18	10	2
	2350	29	17	5
	2950	43	26	5
16	2100	24	14	2
	2800	39	24	5
	3500	56	37	7

ATTENTION INSTALLERS AND SERVICE TECHNICIANS!

R-410A Refrigerant Quick Reference Guide

- R-410A refrigerant operates at 50-70 percent higher pressures than R-22. Be sure that servicing equipment and replacement components are designed to operate with R-410A refrigerant.
- R-410A refrigerant cylinders are rose colored.
- Recovery cylinder service pressure rating must be 400 psig, DOT 4BA400 or DOT BW400.
- R-410A refrigerant systems should be charged with liquid refrigerant. Use a commercial type metering device in the manifold hose when charging into suction line with compressor operating.
- Manifold sets should be 700 psig high side and 180 psig low side with 550 psig low-side retard.
- Use hoses with 700 psig service pressure rating.
- Leak detectors should be designed to detect HFC refrigerant.
- R-410A refrigerant, as with other HFCs, is only compatible with POE oils.
- Vacuum pumps will not remove moisture from oil.
- Do not use liquid-line filter driers with rated working pressures less than 600 psig.
- Do not leave R-410A refrigerant suction line filter driers in line longer than 72 hours.
- Do not install a suction-line filter drier in liquid-line.
- POE oils absorb moisture rapidly. Do not expose oil to atmosphere.
- POE oils may cause damage to certain plastics and roofing materials.
- Wrap all filter driers and service valves with wet cloth when brazing.
- A factory-approved liquid-line filter drier is required on every unit.
- Do NOT use an R-22 expansion device.
- If indoor unit is equipped with an R-22 expansion device, it must be changed to a hard-shutoff R-410A refrigerant expansion device.
- Never open system to atmosphere while it is under a vacuum.
- When system must be opened for service, recover refrigerant, evacuate then break vacuum with dry nitrogen and replace filter driers. Evacuate to 500 microns prior to recharging.
- All indoor coils must be installed with a hard-shutoff R-410A refrigerant expansion metering device.
- Do not vent R-410A refrigerant into the atmosphere.
- Do not use capillary tube coils.
- Observe all **warnings**, **cautions**, and **bold** text.

Troubleshooting Guide

Cooling Service Analysis

PROBLEM	CAUSE	REMEDY
Compressor and condenser fan will not start.	Power failure.	Call power company.
	Fuse blown or circuit breaker tripped.	Replace fuse or reset circuit breaker.
	Defective thermostat, contactor, transformer, or control relay.	Replace component.
	Insufficient line voltage.	Determine cause and correct.
	Incorrect or faulty wiring.	Check wiring diagram and rewire correctly.
	Thermostat setting too high.	Lower thermostat setting below room temperature.
Compressor will not start but condenser fan runs.	Faulty wiring or loose connections in compressor circuit.	Check wiring and repair or replace.
	Compressor motor burned out, seized, or internal over-load open.	Determine cause. Replace compressor.
	Defective overload.	Determine cause and replace.
	Compressor locked out	Determine cause for safety trip and reset lockout.
	One leg of 3-phase power dead.	Replace fuse or reset circuit breaker. Determine cause.
Compressor cycles (other than normally satisfying thermostat).	Refrigerant overcharge or undercharge.	Recover refrigerant, evacuate system, and recharge to nameplate.
	Defective compressor.	Replace and determine cause.
	Insufficient line voltage.	Determine cause and correct.
	Blocked condenser.	Determine cause and correct.
	Defective overload.	Determine cause and replace.
	Defective thermostat.	Replace thermostat.
	Faulty condenser-fan motor.	Replace.
	Restriction in refrigerant system.	Locate restriction and remove.
Compressor operates continuously.	Dirty air filter.	Replace filter.
	Unit undersized for load.	Decrease load or increase unit size.
	Thermostat set too low.	Reset thermostat.
	Low refrigerant charge.	Locate leak, repair, and recharge.
	Air in system.	Recover refrigerant, evacuate system, and recharge.
	Condenser coil dirty or restricted.	Clean coil or remove restriction.
Excessive head pressure.	Dirty drier filter.	Replace filter.
	Dirty condenser coil.	Clean coil.
	Refrigerant overcharged.	Recover excess refrigerant.
	Faulty TXV.	1. Check TXV bulb mounting and secure tightly to suction line. 2. Replace TXV if stuck open or closed.
	Air in system.	Recover refrigerant, evacuate system, and recharge.
	Condenser air restricted or air short-cycling.	Determine cause and correct.
Head pressure too low.	Low refrigerant charge.	Check for leaks, repair, and recharge.
	Restriction in liquid tube.	Remove restriction.
Excessive suction pressure.	High heat load.	Check for source and eliminate.
	Faulty TXV.	1. Check TXV bulb mounting and secure tightly to suction line. 2. Replace TXV if stuck open or closed.
	Refrigerant overcharged.	Recover excess refrigerant.
Suction pressure too low.	Dirty air filter.	Replace filter.
	Low refrigerant charge.	Check for leaks, repair, and recharge.
	Metering device or low side restricted.	Remove source of restriction.
	Faulty TXV.	1. Check TXV bulb mounting and secure tightly to suction line. 2. Replace TXV if stuck open or closed.
	Insufficient evaporator airflow.	Increase air quantity. Check filter and replace if necessary.
	Temperature too low in conditioned area.	Reset thermostat.
	Field-installed filter drier restricted.	Replace.

MANDATORY START-UP CHECK LIST AND RECORD

IMPORTANT!

This page is a mandatory checklist & record – the check to be executed and data to be recorded for future reference incase of failure.
A copy of this checklist data has to be submitted to carrier representative. Completion of this checklist is a must for any field claim, no field support will be provided for incomplete or blank checklists.

Preliminary Information

Outdoor Model Number:	Outdoor Serial Number:
Indoor Model Number:	Indoor Serial Number:
Startup Date:	Technician Name:
Additional Accessories:	

Pre-Start-Up Checklist	Yes	No	NA
Outdoor Unit			
Is there any shipping damage?			
If the unit is damaged, Please specify where:			
Will this damage prevent the unit start-up?			
Check power supply to see if it matches the unit data plate?			
Has the ground wire been properly connected?			
Are the circuit protection to the unit sized and installed properly?			
Are the power wires to the unit sized and intalled properly?			
Piping			
Are refrigerant lines connected to service valve sets?			
Are control power lines connected to control power terminal block?			
Are terminal snug in the housing?			
Are the service valves opened and backseated ?			
Are the Stem Valves Installed and snug?			
Have all the refrigerant connections and piping joints checked for leaks?			
Indoor Fan Coil Unit Piping			
Check if the accurater device is installed in fan coil unit?			
Have refrigerant connections been checked for leak?			
Is condensate line connected?			
Does condensate line drain freely?			
Controls			
Are control power lines and control cables routed separately (Not in the same conduit and not in same multi-conductor cable)?			
Are control wires connected to the same circuit as associated refrigerant lines?			
Check to make sure the subbase mounting to wall is secure? (Don't apply excessive force to mounting screw)			
Units With Wireless Remote Controller			
Check mounting of interface board, are standoffs used to maintain fixed sepration above sheet metal chassis?			
Check connection of power supply plug (2-circuit molex plug) on interface board, is the blue lead connected to pin1?			
Are fresh batteries intalled properly in the fan coil remote controller?			
Does remote controller backlight illuminate when the button is pressed?			
Fan System			
Does fan rotate freely?			
Are air filters in place?			
Indoor Power Supply			
Does the power supply match the fan coil unit data plate?			
Is ground wire connected?			
Start-Up Checklist			
Check Indoor Fan Operation Under Ceiling Fan Coil Units			
Select fan mode, then initiate test sequence. Does the fan coil start at low speed , then shift to medium then to high?			
Start System Operation at the Fan Coil Unit			
Select cooling mode and adjust set point to be below current room temperature, Observe operation of outdoor condensing unit			
Does compressor start (After Initial Time Delay) and Run?			
Does outdoor fan run or cycle according to space requirements?			

De-select cooling mode at indoor fan coil unit, after atleast 15 minutes of running time and record all information below:

Outdoor Unit	
Compressor Amps(L1/L2/L3)	
Oil Pressure	
Vapor Line Pressure	
Vapor Line Temp	
Discharge Pressure	
Discharge Line Temp	
Entering Outdoor Air Temp	
Leaving Outdoor Air Temp	

Fan Coil Unit	
Indoor Entering Air dB(Dry Bulb) Temp	
Indoor Entering Air dB(Wet Bulb) Temp	
Indoor Leaving Air dB(Wet Bulb) Temp	
Indoor Leaving Air dB(Wet Bulb) Temp	

TEAR ALONG THE DOTTED LINE

NOTES

